

Technische Goedkeuring ATG met Certificatie



ATG 15/2802

Venstersysteem met profielen
uit aluminium met thermische
onderbreking

**Blyweert Aluminium
Triton en Triton HI**

Geldig van 31/07/2015
Tot 30/07/2018

Goedkeurings- en Certificatie-operator



BCCA

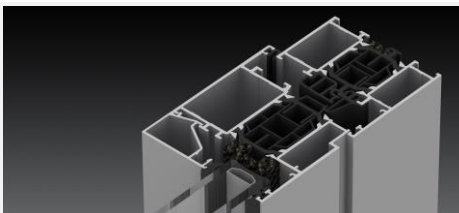

Belgian Construction Certification Association
Aarlenstraat, 53 - 1040 Brussel
www.bcca.be - info@bcca.be

Houder Technische Goedkeuring:
Blyweert aluminium NV
Zwaarveld 44
9220 Hamme
Tel.: +32 52 484848
Fax.: +32 52 484816
Website: www.blyweertaluminium.com
E-mail: info@blyweertaluminium.com

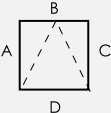
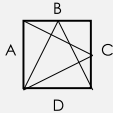
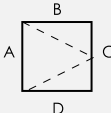
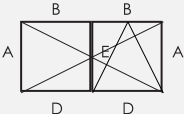

Technische goedkeuring	Certificatie
✓ Aluminium profielen met thermische onderbreking	✓ Productie van aluminium profielen met thermische onderbreking
✓ Venstersysteem	

Goedgekeurde types vensters conform NBN B 25-002-1

✓  Vaste vensters	✓  Binnenvallend venster
✓  Naar binnen opengaand draai of draaikipvenster (enkele vleugel)	✓  Buitendraaiend venster
✓  Naar binnen opengaand draai- of draaikipvenster (stolpvenster)	✓  Samengestelde vensters

1 Doel en draagwijdte van de technische goedkeuring

Een technische goedkeuring van een systeem betreft een gunstige beoordeling door een onafhankelijke goedkeuringsoperator aangeduid door de vzw BUTgb van een systeem voor een bepaalde beoogde toepassing op basis van de op datum van goedkeuring beschikbare testgegevens. Het resultaat van deze beoordeling wordt in een goedkeuringstekst vastgelegd. In deze tekst worden de in het systeem toegelaten componenten geïdentificeerd en worden de te verwachten prestaties bepaald van de producten die vervaardigd worden met de toegelaten componenten van het systeem, gesteld dat deze producten vervaardigd, geplaatst, gebruikt en onderhouden worden volgens de methodes eigen aan het systeem en volgens de beginselen uiteengezet in deze goedkeuringstekst.

De technische goedkeuring gaat gepaard met een periodieke opvolging en een aanpassing aan de stand van de techniek wanneer deze wijzigingen pertinent zijn. Een jaarlijkse revisie wordt opgelegd, waarbij de tekst wordt geactualiseerd.

De instandhouding van de technische goedkeuring van een systeem vereist dat de componenten van het systeem voldoen aan de in deze tekst beschreven kenmerken en dat de goedkeuringshouder te allen tijde kan bewijzen dat hij het nodige doet om de verwerkers van het systeem te begeleiden, zodat de in de goedkeuring beschreven prestaties kunnen bereikt worden. De opvolging hiervan is essentieel voor het vertrouwen in de overeenkomstigheid met de technische goedkeuring. Deze opvolging wordt toevertrouwd aan een door de BUTgb aangeduide certificatieoperator.

2 Voorwerp

De technische goedkeuring van een venstersysteem met profielen uit aluminium met thermische onderbreking geeft de technische beschrijving van een venstersysteem, dat bestaat uit de in paragraaf 4 vermelde componenten, de in paragraaf 5 geschetste montagewijze, de in paragraaf 6 geschetste plaatsingswijze en de in paragraaf 7 geschetste onderhouds- en beschermingsmaatregelen.

Onder voorbehoud van voormelde voorwaarden, steunend op het initiële typeonderzoek van de goedkeuringshouder, het complementaire proefprogramma dat door de goedkeuringshouder in opdracht van de BUTgb werd uitgevoerd evenals de actuele kennis van de techniek en haar normalisatie, kan men veronderstellen dat de prestatieniveaus vermeld in paragraaf 8 geldig zijn voor de vermelde types vensters.

Voor andere componenten, constructiewijzen, plaatsingswijzen en/of prestatieniveaus is deze technische goedkeuring niet zonder meer van toepassing, en moet bijkomend onderzoek verricht worden.

De goedkeuringshouder en de schrijnwerfabrikanten mogen enkel verwijzen naar deze goedkeuring voor deze toepassingen van het venstersysteem waarvoor kan worden aangetoond dat de beschrijving geheel conform is aan de in de goedkeuring vooropgestelde catalogisering en richtlijnen.

De goedkeuringstekst, evenals de certificatie van de overeenstemming van de componenten met de goedkeuringstekst en de opvolging van de begeleiding van de schrijnwerfabrikanten, staan los van de kwaliteit van de individuele vensters. De schrijnwerfabrikant, de plaatser en de voorschrijver blijven bijgevolg onverminderd verantwoordelijk voor de overeenstemming van de uitvoering met de bepalingen van het bestek.

3 Systeem

Het venstersysteem "Triton" is geschikt voor het maken van:

- Vaste vensters
- Naar binnen opengaand draai of draaikipvenster met enkele of dubbele vleugel
- Naar buiten opengaand draaivenster met enkele vleugel
- Samengestelde vensters

Het venster- en deursysteem "Triton" heeft twee uitvoeringsvarianten:

- "Triton": Dit is de basisuitvoering, die gebruik maakt van thermische onderbrekingen uit polyamide PA 6.6
- "Triton HI": Dit is de uitvoering met verbeterde thermische prestaties, die gebruik maakt van thermische onderbrekingen uit ABS en PVC profielen welke in de holle ruimten tussen de thermische onderbrekingen worden geplaatst

De binnen- en buitendelen kunnen in eenzelfde kleur worden gepoederlakt of geanodiseerd; als alternatief kunnen de binnen- en buitendelen elk in een andere kleur worden gepoederlakt of geanodiseerd.

Alle weerstandsprofielen waarvan sprake bestaan uit twee delen van aluminium, namelijk een binnen- en een buitendeel, die afzonderlijk geëxtrudeerd zijn en die doorlopend verbonden worden door inklemming van twee polyamide PA 6.6 (profielen met nummers P-03-xxx) of ABS (profielen met nummers P-03-Axxx) strippen die een thermische onderbreking vormen.

Deze goedkeuring steunt, voor wat betreft de mechanische prestaties van de profielen met thermische onderbreking, op de technische goedkeuring van het assemblagesysteem van aluminium profielen met thermische onderbreking ATG/H 895.

4 Onderdelen

Voor een grafische weergave van de onderdelen wordt verwezen naar de bijlage van deze goedkeuring, in elektronisch formaat, op de website van de BUTgb.

4.1 Weerstandsprofielen van aluminium met thermische onderbreking

Onderstaande tabel geeft de belangrijkste gegevens weer van de weerstandsprofielen die gebruikt mogen worden in de realisatie van venster in overeenstemming met deze goedkeuring.

De stijfheid I_{xx} van het profiel tegen lasten loodrecht op het glasvlak (zoals windbelasting), is functie van de lengte van het beschouwde profiel; de waarde van I_{xx} is gegeven voor verschillende lengtes van het profiel.

Tabel 1 – Weerstandprofielen van aluminium met thermische onderbreking

Profielen	$I_{xx, 1m}$ (L = 100 cm)	$I_{xx, 1.4m}$ (L = 140 cm)	$I_{xx, 1.8m}$ (L = 180 cm)	$I_{xx, 2.2m}$ (L = 220 cm)	$I_{xx, 2.6m}$ (L = 260 cm)	$I_{xx, 3m}$ (L ≥ 300 cm)	I_{yy}	Lineaire massa
	cm ⁴	cm ⁴	cm ⁴	cm ⁴	cm ⁴	cm ⁴	cm ⁴	kg/m
Profielen voor de realisatie van vaste vensterkaders en vaste vensters								
P-03-100	11,8	16,1	19,5	21,9	23,7	25,0	6,2	1,18
P-03-101	13,6	18,7	22,9	26,2	28,7	30,6	16,1	1,50
P-03-102	14,6	20,1	24,9	28,7	31,6	33,8	25,8	1,69
P-03-103	19,4	26,8	34,0	40,5	46,0	50,5	138,5	2,86
P-03-104	12,9	17,6	21,5	24,4	26,6	28,2	11,0	1,37
P-03-108	23,0	30,4	36,8	41,9	45,8	48,9	18,4	1,79
P-03-109	49,0	60,2	70,0	78,1	84,5	89,4	20,7	2,10
P-03-110	61,9	75,3	87,4	97,4	105,3	111,6	33,0	2,37
P-03-115	57,4	69,9	80,6	89,0	95,5	100,4	23,2	2,08
P-03-116	11,9	16,1	19,5	22,0	23,7	25,1	6,1	1,19
P-03-117	11,7	16,0	19,4	21,8	23,6	25,0	6,4	1,21
P-03-118	13,5	18,6	22,8	26,1	28,6	30,5	16,5	1,53
P-03-123	19,4	26,6	33,7	40,0	45,4	49,8	132,9	2,82
P-03-A100	12,6	17,0	20,3	22,7	24,3	25,5	6,2	1,18
P-03-A101	14,5	19,8	24,0	27,2	29,6	31,4	16,1	1,50
P-03-A102	15,5	21,3	26,1	29,8	32,6	34,7	25,8	1,69
P-03-A103	20,6	28,5	36,1	42,6	48,0	52,4	138,5	2,86
P-03-A104	13,7	18,6	22,4	25,3	27,4	28,9	11,0	1,37
P-03-A108	24,3	32,0	38,4	43,4	47,2	50,1	18,4	1,79
P-03-A109	50,9	62,6	72,6	80,6	86,7	91,4	20,7	2,10
P-03-A110	64,1	78,2	90,6	100,5	108,2	114,1	33,0	2,37
P-03-A115	59,5	72,6	83,3	91,6	97,8	102,4	23,2	2,08
P-03-A116	12,6	17,0	20,3	22,7	24,4	25,6	6,1	1,19
P-03-A117	12,5	16,9	20,2	22,6	24,3	25,5	6,4	1,21
P-03-A118	14,3	19,6	23,9	27,1	29,5	31,3	16,5	1,53
P-03-A123	20,5	28,3	35,7	42,1	47,4	51,6	132,9	2,82
Profielen voor de realisatie van venstervleugels								
P-03-200	16,9	22,4	26,8	30,0	32,3	34,1	8,4	1,27
P-03-201	19,5	26,2	31,8	36,1	39,5	42,0	19,8	1,61
P-03-202	21,0	28,1	34,3	39,3	43,2	46,1	30,7	1,80
P-03-210	17,2	22,8	27,3	30,6	33,0	34,8	8,7	1,31
P-03-211	19,8	26,5	32,2	36,7	40,1	42,7	20,5	1,65
P-03-212	21,2	28,4	34,7	39,8	43,8	46,9	31,7	1,84
P-03-230B	18,3	24,5	29,6	33,5	36,4	38,6	11,9	1,52
P-03-231B	20,3	27,2	33,1	37,8	41,5	44,3	23,4	1,77
P-03-240B	18,7	25,0	30,2	34,2	37,2	39,4	12,3	1,57
P-03-241B	20,6	27,6	33,7	38,5	42,3	45,2	24,2	1,82
P-03-A200	17,9	23,6	27,9	30,9	33,1	34,7	8,4	1,27
P-03-A201	20,7	27,6	33,2	37,5	40,6	43,0	19,8	1,61
P-03-A202	22,2	29,6	35,9	40,8	44,5	47,4	30,7	1,80
P-03-A210	18,2	24,0	28,4	31,5	33,8	35,5	8,7	1,31
P-03-A211	21,0	28,0	33,7	38,1	41,3	43,8	20,5	1,65
P-03-A212	22,4	30,0	36,4	41,4	45,2	48,1	31,7	1,84
P-03-A230B	19,5	25,9	30,9	34,7	37,4	39,5	11,9	1,52
P-03-A231B	21,5	28,7	34,7	39,4	42,9	45,5	23,4	1,77
P-03-A240B	19,8	26,4	31,6	35,4	38,3	40,4	12,3	1,57
P-03-A241B	21,9	29,2	35,4	40,1	43,7	46,4	24,2	1,82

Profielen	$I_{xx, 1m}$ (L = 100 cm)	$I_{xx, 1,4m}$ (L = 140 cm)	$I_{xx, 1,8m}$ (L = 180 cm)	$I_{xx, 2,2m}$ (L = 220 cm)	$I_{xx, 2,6m}$ (L = 260 cm)	$I_{xx, 3m}$ (L ≥ 300 cm)	I_{yy}	Lineaire massa
	cm ⁴	cm ⁴	cm ⁴	cm ⁴	cm ⁴	cm ⁴	cm ⁴	kg/m
Profielen voor de realisatie van vaste stijlen en dwarsregels								
P-03-300	12,7	17,6	21,5	24,4	26,5	28,1	10,2	1,55
P-03-301	14,4	20,0	24,8	28,6	31,4	33,6	22,6	1,64
P-03-302	15,4	21,4	26,7	30,9	34,2	36,8	34,3	1,83
P-03-303	20,0	27,5	34,9	41,5	47,1	51,7	155,0	2,86
P-03-304	24,0	32,6	41,5	50,0	57,6	64,2	406,9	3,92
P-03-305	45,5	55,8	64,6	71,5	76,8	80,8	14,3	2,02
P-03-306	49,8	60,9	70,9	79,2	85,9	91,1	29,1	2,40
P-03-309	12,7	17,6	21,6	24,6	26,9	28,6	14,7	1,47
P-03-310	13,2	18,4	22,7	26,0	28,4	30,2	10,3	1,41
P-03-311	14,7	20,6	25,8	29,9	33,0	35,5	23,3	1,73
P-03-312	15,7	21,9	27,5	32,1	35,7	38,5	35,4	1,92
P-03-315	46,3	56,6	65,4	72,3	77,7	81,7	25,5	1,99
P-03-319	14,5	20,1	25,0	28,9	32,0	34,3	29,9	1,82
P-03-320	16,8	23,0	28,1	32,0	34,9	37,2	10,7	1,46
P-03-321	19,2	26,1	32,2	37,1	40,9	43,8	24,3	1,78
P-03-332	95,2	112,8	129,5	144,1	156,2	166,1	34,4	2,74
P-03-A300	13,6	18,6	22,4	25,2	27,3	28,8	10,2	1,55
P-03-A301	15,4	21,2	26,0	29,7	32,4	34,5	22,6	1,64
P-03-A302	16,4	22,7	28,0	32,2	35,4	37,9	34,3	1,83
P-03-A303	21,2	29,3	37,0	43,7	49,2	53,7	155,0	2,86
P-03-A304	25,4	34,7	44,1	52,9	60,6	67,1	406,9	3,92
P-03-A305	47,3	58,0	66,8	73,6	78,6	82,4	14,3	2,02
P-03-A306	51,6	63,3	73,6	81,8	88,3	93,2	29,1	2,40
P-03-A309	13,6	18,6	22,6	25,5	27,7	29,3	14,7	1,47
P-03-A310	14,1	19,5	23,8	26,9	29,3	31,0	10,3	1,41
P-03-A311	15,7	21,9	27,1	31,1	34,2	36,5	23,3	1,73
P-03-A312	16,7	23,3	29,0	33,5	37,0	39,7	35,4	1,92
P-03-A315	48,0	58,8	67,7	74,4	79,5	83,3	25,5	1,99
P-03-A319	15,4	21,3	26,3	30,1	33,1	35,3	29,9	1,82
P-03-A320	17,8	24,2	29,3	33,2	36,0	38,1	10,7	1,46
P-03-A321	20,3	27,6	33,8	38,6	42,2	45,0	24,3	1,78
P-03-A332	98,1	116,8	134,1	148,8	160,7	170,2	34,4	2,74
Profielen voor de realisatie van venstermakelaars								
P-03-400	11,8	16,0	19,3	21,8	23,6	24,9	6,8	1,26
P-03-405	14,2	17,8	20,4	22,2	23,5	24,5	8,6	1,20
P-03-430B	12,8	17,4	21,0	23,7	25,8	27,3	7,0	1,31
P-03-A400	12,6	16,9	20,1	22,5	24,2	25,4	6,8	1,26
P-03-A405	14,9	18,5	21,0	22,8	24,0	24,8	8,6	1,20
P-03-A430B	13,6	18,3	22,0	24,6	26,5	27,9	7,0	1,31
Profielen voor de realisatie van verborgen ontwatering								
P-03-514	10,5	14,1	16,7	18,6	20,0	21,0	3,3	1,21
P-03-515	13,6	18,5	22,7	25,9	28,4	30,2	19,2	1,56
P-03-516	18,5	25,3	31,7	37,3	42,0	45,8	113,9	2,56
P-03-A514	11,2	14,8	17,4	19,2	20,5	21,4	3,3	1,21
P-03-A515	14,4	19,6	23,7	26,9	29,2	31,0	19,2	1,56
P-03-A516	19,6	26,8	33,5	39,1	43,7	47,4	113,9	2,56

4.2 Hang- en sluitwerk

De fiches in bijlage (1 tot en met 7) geven per type hang- en sluitwerk:

- het type (venster)
- de toegelaten openingswijze
- de maximale afmetingen van de vleugels
- het aantal sluit- en rotatiepunten in functie van de afmetingen van de vleugel en van de gebruikte profielen
- de verschillende normatieve criteria welke werden vastgesteld.

Onderstaande tabel geeft een opsomming weer van de belangrijkste eigenschappen van de types hang- en sluitwerk die gebruikt mogen worden in de realisatie van vensters in overeenstemming met deze goedkeuring. De vermelde eigenschappen van het hang- en sluitwerk beperken de eigenschappen voor de vensters die er van worden voorzien.

Tabel 2 – Samenvatting eigenschappen hang- en sluitwerk

	Agressiviteits-klasse	Duurzaamheid	Maximaal gewicht
Hang- en sluitwerk voor vensters			
Sobinco Chrono	Gemiddeld (klasse 4)	15.000 cycli (klasse 4)	170 kg
Sobinco meerpuntslot	Gemiddeld (klasse 4)	200.000 cycli (klasse 7)	120 kg
Fapim Galipius 2	Gemiddeld (klasse 4)	15.000 cycli (klasse 4)	130 kg
Savio Ribanta Incanto	Gemiddeld (klasse 4)	15.000 cycli (klasse 4)	100 kg
Roto NT Designo Alu	Gemiddeld (klasse 4)	15.000 cycli (klasse 4)	150 kg

4.3 Dichtingen

Onderstaande lijst geeft een opsomming weer van de dichtingen die gebruikt mogen worden in de realisatie van vensters in overeenstemming met deze goedkeuring (zie figuren "Toebehoren").

- Binnendraaiend:
 - Middendichting: A-GS-135 + A-GS-136 (met hoekstuk A-00-135)
 - Aanslagdichting: A-GS-131
- Buitendraaiend:
 - Aanslagdichting: A-GS-133
 - Glasdichtingen:
 - binnen: A-GS-303, A-GS-304, A-GS-305, A-GS-306, A-GS-308
 - buiten: A-GS-100, A-GS-110, A-GS-111

Het water dat zich onderaan horizontale profielen kan verzamelen, wordt afgevoerd langs drainagegaten in het zichtvlak van het profiel, met een maximale tussenafstand van 100 cm en welke door kapjes worden afgedekt, of door het gebruik van een profiel voor verborgen drainage wat onder het vaste kader wordt gevestigd.

4.4 Toebehoren

Onderstaande lijst geeft een opsomming weer van de toebehoren die gebruikt mogen worden in de realisatie van vensters in overeenstemming met deze goedkeuring.

4.4.1 Aluminium profielen zonder thermische onderbreking

- Glaslatten: (zie figuren "profielen")
 - gewone glaslatten
 - tubulaire glaslatten
- Dorpels en sierlijsten: (zie figuren "profielen")
- Aluminium versterkingsprofielen: (zie figuren "profielen")
- Druiplijsten en andere profielen: (zie figuren "profielen")

4.4.2 Aanvullende metalen stukken

- Hoekverbinders: (zie figuren "toebehoren")
 - Pershoeken
 - Schroefhoeken
- T-verbinders: (zie figuren "toebehoren")
 - Schroefbare T-verbinder
- Eindstuk waterlijst : (zie figuren "toebehoren")

4.4.3 Aanvullende kunststof stukken

- Afdekelement drainageopeningen : (zie figuren "toebehoren")
- Glassteunblok : (zie figuren "toebehoren")
- Makelaareindstuk : (zie figuren "toebehoren")
- Flensversterking : (zie figuren "toebehoren")
- Andere: (zie figuren "toebehoren")

4.5 Beglazing

De beglazing moet van een ATG goedkeuring en/of Benor attest genieten.

Een lijst met goedgekeurde types beglazing kan worden geraadpleegd op deze website: <http://www.bcca.be/>.

Het profielsysteem is geschikt voor beglazingen met een dikte van 13 mm tot 66 mm.

4.6 Kitten voor glas- en ruwbouwaansluiting

Kitten worden gebruikt als dichtingsvoeg van de ruwbouw of voor het opkitten van glas indien geen voorgevormde dichtingen gebruikt worden; ze moeten goedgekeurd zijn door de BUtgb voor de gebruikte toepassingen worden aangewend conform STS 56.1.

De types kit die worden aangewend zijn:

- Voor de aansluiting met het metselwerk: bouwkit 12.5 E, 20 LM of 25 LM.
- Voor het opkitten van het glas (indien geen voorgevormde dichtingen gebruikt worden): glaskit 20 LM of 25 LM

Een lijst met goedgekeurde types kitten kan worden geraadpleegd op deze website: <http://www.bcca.be/>.

4.7 Systeemgebonden lijmen en kitten

Systeemgebonden lijmen worden gebruikt bij de bevestiging van de profielen op of tegen elkaar, bij de dichting van makelaars, bij de hoekaansluitingen van de dichtingen en de montage van voormelde toebehoren; ze moeten goedgekeurd zijn door de BUtgb voor de gebruikte toepassing.

Aluminium zaagsnedes moeten ontvet en gepassiveerd worden, door het gebruik van Systeemhouder "Ontvetter" en Systeemhouder "Passivator".

De types lijmen en kitten die worden aangewend zijn:

- Tussen twee aluminium oppervlakken: A-00-902
- Voor de dichting van makelaars: A-00-902
- Voor de montage van T- en hoekverbinders: A-00-901
- Tussen twee dichtingen: A-00-908
- Voor de bevestiging van kunststof: A-00-900

Meteen na de montage worden de zichtvlakken ontdaan van lijmresten met een niet-agressief reinigingsmiddel A-00-903.

5 Montagevoorschriften

5.1 Vervaardiging van de profielen met thermische onderbreking

De thermisch onderbroken profielen die in het kader van deze technische goedkeuring van het venstersysteem "Triton" worden gebruikt, worden vervaardigd door bedrijven die hiervoor door de goedkeuringshouder worden erkend en hiervoor door BCCA worden gecertificeerd.

5.2 Ontwerp en vervaardiging van de vensters

De vensters met thermisch onderbroken profielen die in het kader van deze technische goedkeuring van het venstersysteem "Triton" worden ontworpen en vervaardigd door schrijnwerkbedrijven die hiervoor door de goedkeuringshouder worden erkend en eventueel hiervoor door BCCA worden gecertificeerd.

Het ontwerp en de vervaardiging moeten voldoen aan:

- Alle geldende wetgeving en regelgeving
- NBN B 25-002-1 (voor vensters)
- NBN S 23-002/A1/AC (voor beglazing)
- De voorschriften opgenomen in de systeemdocumentatie van de goedkeuringshouder

De actuele lijst met gecertificeerde schrijnwerkfabrikanten kan worden geraadpleegd op deze website: www.butgb.be.

6 Plaatsing

Het plaatsen van vensters gebeurt overeenkomstig TV 188 "Plaatsen van buitenschrijnwerk" van het WTCB en de plaatsingsrichtlijnen opgesteld door de goedkeuringshouder.

7 Onderhoud

Reiniging van de beglazing, de beglazingsvoegen, de vleugels en de vaste raamkaders, moet gebeuren naargelang van de vervuilingsgraad.

De reiniging gebeurt met zuiver water, waaraan eventueel een weinig detergent toegevoegd werd. Het gebruik van agressieve of schurende producten, van organische oplosmiddelen (bv. alcohol) of van sterk alkalische producten (bv. ammoniak) is verboden. De reiniging van het schrijnwerk met water onder hoge druk wordt ten stelligste afgeraden.

Geanodiseerd aluminium: voor de verwijdering van sterk hechtend vuil kan men een zacht schuurmiddel of een detergent gebruiken. Het gebruik van basische of zure producten en van grove schuurmiddelen (bv. staalwol) moet zoveel mogelijk vermeden worden.

Gelakt aluminium: de reinigingsproducten moeten neutraal zijn (pH begrepen tussen 6 en 8) en mogen geen schuurmiddelen bevatten.

Het jaarlijkse onderhoud bestaat uit:

- Vrijmaken van de ontwateringsgroeven van de vleugels en de vaste raamkaders en nazicht van de reinheid van de decompressiekamer. Nazicht van de werking van deze elementen.
- Visuele controle van de staat van de soepele beglazingsvoegen, een controle van hun hechting aan de ondergrond (beglazing, schrijnwerk, ruwbouw) en vervanging van de delen die gebreken vertonen (bv. door vogels beschadigde voegen). Indien de voegen beschilderd werden, dient men – indien nodig – hun afwerking te vernieuwen.

- De soepele profielen ter verzekering van de luchtdichtheid moeten gereinigd worden met zuiver water waaraan eventueel een weinig detergent toegevoegd werd. Men dient over te gaan tot een nazicht van hun algemene staat, van de staat van de gelaste verbindingen (bv. in de hoeken) en tot de vervanging van de verharde of beschadigde delen. Deze profielen mogen niet beschilderd worden.
- Nazicht en eventuele vervanging van de soepele kitvoegen ter verzekering van de aansluiting tussen het schrijnwerk en de ruwbouw.
- Reiniging en nazicht van de verluchttingsroosters (werking, bevestigingen).
- Het hang- en sluitwerk moet gereinigd worden met een doek die licht bevochtigd werd met water waaraan eventueel een weinig detergent toegevoegd werd.
- De beweegbare onderdelen moeten gesmeerd worden:
 - cilinders: grafiet of siliconenspray; olie en vet mogen niet gebruikt worden
 - beslag: niet-agressieve olie of zuurvrij vet
 - sluitplaten: niet-agressieve olie, zuurvrij vet of vaseline.
- Bij een gebrekkige werking kan het soms nodig zijn het hang- en sluitwerk af te stellen, te herstellen, of – indien nodig – te vervangen.

Het hang- en sluitwerk moet opnieuw afgesteld worden bij gebruiksproblemen of wanneer de samendrukking van de soepele profielen ter verzekering van de luchtdichtheid niet langer gewaarborgd is; dit dient te gebeuren door een specialist.

8 Prestatiekenmerken

Alle prestatiekenmerken vermeld in deze goedkeuring werd bepaald door proeven of berekeningen volgens de methodiek vermeld in de norm NBN B 25-002-1, op vensters die conform zijn aan de in deze goedkeuring opgenomen beschrijvingen en opsommingen, of onderdelen daarvan.

De stand van de wetenschap laat toe te veronderstellen dat vensters die conform zijn aan de in deze goedkeuring opgenomen beschrijvingen en opsommingen, of onderdelen daarvan, deze prestaties evenaren.

8.1 Prestaties van de profielen

8.1.1 Thermische eigenschappen

Voor een eerste benadering of bij gebrek aan nauwkeurige berekeningswaarden (tabel 4 tot en met tabel 7) kunnen voor alle courante berekeningen de U_f en U_{10} waarden uit tabel 3 gebruikt worden.

- U_f stelt de thermische doorlaatbaarheid van een profiel met een gegeven lengte van de thermische onderbreking voor.
- U_{10} stelt de thermische doorlaatbaarheid van een profiel alsof de ontwikkelde oppervlakte gelijk is aan de geprojecteerde oppervlakte met een gegeven lengte van de thermische onderbreking voor. De waarde van U_{10} kan gebruikt worden, samen met de geometrische eigenschappen van een profiel of profielcombinatie, om de U_f of R waarde te berekenen, zie NBN B 62-002.

Tabel 3 – Waarden van U_{i0} en U_f bij gebrek aan de nauwkeurige berekeningswaarde

Hoogte van de thermische onderbreking	Type profiel	U_{i0}	U_f
mm		W/(m ² .K)	W/(m ² .K)
25	alle profielen waarvan de kleinste thermische onderbreking 25 mm meet	2,73	3,25
30	alle profielen waarvan de kleinste thermische onderbreking 30 mm meet	2,58	3,04

De nauwkeurig bepaalde waarden van U_f van tabel 4 tot en met tabel 9 kunnen gebruikt worden voor de profielencombinatie in referentie. De berekeningen volgens welke deze waarden zijn bekomen, zijn gecertificeerd door de certificatieoperator BCCA.

Tabel 4 – Berekening volgens NBN EN ISO 10077-2: vast kader zonder vleugel

Vast kader	Vleugel	Zichtbare breedte	U_f Triton	U_f Triton HI
		mm	W/(m ² .K)	W/(m ² .K)
P-03-(A)100	–	51	2,55	1,50
P-03-(A)101	–	67	2,39	1,52
P-03-(A)102	–	77	2,33	1,53
P-03-(A)104	–	60	2,45	1,73

Tabel 5 – Berekening volgens NBN EN ISO 10077-2: vast kader met vleugel

Vast kader	Vleugel	Zichtbare breedte	U_f Triton	U_f Triton HI
		mm	W/(m ² .K)	W/(m ² .K)
P-03-(A)100	P-03-(A)200	92	2,64	1,75
	P-03-(A)201	108	2,54	1,73
	P-03-(A)202	118	2,49	1,72
	P-03-(A)230B	98	2,60	1,74
	P-03-(A)231B	111	2,52	1,73
	P-03-(A)210	92	2,64	1,75
	P-03-(A)211	108	2,54	1,73
	P-03-(A)212	118	2,49	1,72
	P-03-(A)240B	98	2,60	1,74
	P-03-(A)241B	111	2,52	1,73
	P-03-(A)101	P-03-(A)200	108	2,54
P-03-(A)201		124	2,47	1,71
P-03-(A)202		134	2,43	1,71
P-03-(A)230B		114	2,51	1,72
P-03-(A)231B		127	2,45	1,71
P-03-(A)210		108	2,54	1,73
P-03-(A)211		124	2,47	1,71
P-03-(A)212		134	2,43	1,71
P-03-(A)240B		114	2,51	1,72
P-03-(A)241B		127	2,45	1,71

Tabel 5 (vervolg) : Berekening volgens NBN EN ISO 10077-2: vast kader met vleugel

Vast kader	Vleugel	Zichtbare breedte	U_f Triton	U_f Triton HI
		mm	W/(m ² .K)	W/(m ² .K)
P-03-(A)102	P-03-(A)200	118	2,49	1,72
	P-03-(A)201	134	2,43	1,71
	P-03-(A)202	144	2,40	1,70
	P-03-(A)230B	124	2,47	1,71
	P-03-(A)231B	137	2,42	1,70
	P-03-(A)210	118	2,49	1,72
	P-03-(A)211	134	2,43	1,71
	P-03-(A)212	144	2,40	1,70
	P-03-(A)240B	124	2,47	1,71
	P-03-(A)241B	137	2,42	1,70
P-03-(A)104	P-03-(A)200	101	2,58	1,84
	P-03-(A)201	117	2,50	1,81
	P-03-(A)202	127	2,46	1,80
	P-03-(A)230B	107	2,54	1,88
	P-03-(A)231B	120	2,48	1,80
	P-03-(A)210	101	2,58	1,84
	P-03-(A)211	117	2,50	1,81
	P-03-(A)212	127	2,46	1,80
	P-03-(A)240B	107	2,54	1,88
	P-03-(A)241B	120	2,48	1,80

Tabel 6 – Berekening volgens NBN EN ISO 10077-2: twee vleugels met makelaar

Makelaar	Vleugel	Zichtbare breedte	U_f Triton	U_f Triton HI
		mm	W/(m ² .K)	W/(m ² .K)
P-03-(A)400	P-03-(A)200	141	2,63	1,75
P-03-(A)400	P-03-(A)201	173	2,51	1,72
P-03-(A)400	P-03-(A)202	193	2,45	1,71
P-03-(A)430	P-03-(A)230B	153	2,57	1,73
P-03-(A)430	P-03-(A)231B	180	2,48	1,72
P-03-(A)400	P-03-(A)210	141	2,63	1,75
P-03-(A)400	P-03-(A)211	173	2,51	1,72
P-03-(A)400	P-03-(A)212	193	2,45	1,71
P-03-(A)430B	P-03-(A)240B	153	2,57	1,73
P-03-(A)430B	P-03-(A)241B	180	2,48	1,72

Tabel 7 – Berekening volgens NBN EN ISO 10077-2: stijl of dwarsregel zonder vleugels

Stijl of dwarsregel	Vleugel	Zichtbare breedte	U_f Triton	U_f Triton HI
		mm	W/(m ² .K)	W/(m ² .K)
P-03-(A)300	–	73	2,47	1,34
P-03-(A)301	–	89	2,33	1,39
P-03-(A)302	–	99	2,27	1,42

Tabel 8 – Berekening volgens NBN EN ISO 10077-2: stijl of dwarsregel met een vleugel

Stijl of dwarsregel	Vleugel	Zichtbare breedte	U _f Triton	U _f Triton HI
		mm	W/(m ² .K)	W/(m ² .K)
P-03-(A)300 of P-03-(A)310	P-03-200	114	2,63	1,65
	P-03-(A)201	130	2,53	1,65
	P-03-(A)202	140	2,48	1,64
	P-03-(A)210	114	2,63	1,65
	P-03-(A)211	130	2,53	1,65
	P-03-212	140	2,48	1,64
	P-03-230B	120	2,59	1,65
	P-03-231B	134	2,51	1,64
	P-03-(A)240B	120	2,59	1,65
	P-03-(A)241B	134	2,51	1,64
P-03-(A)301 of P-03-(A)311	P-03-(A)200	130	2,53	1,65
	P-03-(A)201	146	2,45	1,64
	P-03-(A)202	156	2,41	1,64
	P-03-(A)210	130	2,53	1,65
	P-03-(A)211	146	2,45	1,64
	P-03-(A)212	156	2,41	1,64
	P-03-(A)230B	136	2,50	1,64
	P-03-(A)231B	150	2,44	1,64
	P-03-(A)240B	136	2,50	1,64
	P-03-(A)241B	150	2,44	1,64
P-03-(A)302 of P-03-(A)312	P-03-(A)200	140	2,48	1,64
	P-03-(A)201	156	2,41	1,64
	P-03-(A)202	166	2,37	1,64
	P-03-(A)210	140	2,48	1,64
	P-03-(A)211	156	2,41	1,64
	P-03-212	166	2,37	1,64
	P-03-230B	146	2,45	1,64
	P-03-(A)231B	160	2,40	1,64
	P-03-(A)240B	146	2,45	1,64
	P-03-(A)241B	160	2,40	1,64

Tabel 9 – Berekening volgens NBN EN ISO 10077-2: stijl of dwarsregel met twee vleugels

Stijl of dwarsregel	Vleugel	Zichtbare breedte	U _f Triton	U _f Triton HI
		mm	W/(m ² .K)	W/(m ² .K)
P-03-(A)300 of P-03-(A)310	P-03-(A)200	155	2,66	1,75
	P-03-(A)201	187	2,52	1,73
	P-03-(A)202	207	2,46	1,72
	P-03-(A)210	155	2,66	1,75
	P-03-(A)211	187	2,52	1,73
	P-03-(A)212	207	2,46	1,72
	P-03-(A)230B	167	2,60	1,74
	P-03-(A)231B	194	2,50	1,73
	P-03-(A)240B	167	2,60	1,74
	P-03-(A)241B	194	2,50	1,73

Tabel 9 (Vervolg) – Berekening volgens NBN EN ISO 10077-2: stijl of dwarsregel met twee vleugels

Stijl of dwarsregel	Vleugel	Zichtbare breedte	U _f Triton	U _f Triton HI
		mm	W/(m ² .K)	W/(m ² .K)
P-03-(A)301 of P-03-(A)311	P-03-(A)200	171	2,59	1,74
	P-03-(A)201	203	2,47	1,72
	P-03-202	223	2,42	1,71
	P-03-210	171	2,59	1,74
	P-03-(A)211	203	2,47	1,72
	P-03-(A)212	223	2,42	1,71
	P-03-(A)230B	183	2,54	1,73
	P-03-231B	210	2,45	1,72
	P-03-240B	183	2,54	1,73
	P-03-(A)241B	210	2,45	1,72
P-03-(A)302 of P-03-(A)312	P-03-(A)200	181	2,55	1,73
	P-03-(A)201	213	2,44	1,72
	P-03-(A)202	233	2,39	1,71
	P-03-(A)210	181	2,55	1,73
	P-03-(A)211	213	2,44	1,72
	P-03-(A)212	233	2,39	1,71
	P-03-(A)230B	193	2,50	1,73
	P-03-(A)231B	220	2,42	1,71
	P-03-(A)240B	193	2,50	1,73
	P-03-(A)241B	220	2,42	1,71

8.1.2 Agressiviteit van de omgeving

De binnen- en buitendelen kunnen in eenzelfde kleur worden gepoederlakt of geanodiseerd; als alternatief kunnen de binnen- en buitendelen elk in een andere kleur worden gelakt of geanodiseerd.

De fabrikant biedt profielen en hulpstukken met verschillende kwaliteiten afwerking aan, met een verschillende weerstand tegen de agressiviteit van de omgeving. Afhankelijk van de gekozen afwerking, zijn de profielengeschikt om in bepaalde klimaatzones te worden gebruikt. De weerstand tegen agressiviteit van de omgeving van het hang- en sluitwerk is eveneens een beperkende factor, zie hiervoor tabel 3; de weerstand tegen agressiviteit van de omgeving van venster is de laagste van de profielen en het hang- en sluitwerk.

Onderstaande tabel 8 vermeldt, afhankelijk van de geografische of plaatselijke agressiviteit, de minimaal vereiste afwerkingskwaliteit.

Tabel 10 – Agressiviteitsniveaus betreffende de afwerking

Geografische agressiviteit	Geanodiseerd	Gelakt	Minimale corrosie-weerstand van het beslag volgens NBN EN 1670
Licht "landelijk"	20 µm	Standaard	Klasse 3
Gematigd "landelijk-industriëel"	20 µm	Standaard	Klasse 3
Gematigd "landelijk-kust"	20 µm	Standaard	Klasse 3
Gemiddeld "industriëel-kust"	20 µm	Standaard	Klasse 4
Streng ("kust")	25 µm	"Seaside"	Klasse 4 ⁽¹⁾
Streng (plaatselijke agressiviteitsfactoren)	25 µm	"Seaside"	Klasse 4 ⁽¹⁾

(1): het gebruik van beslag met weerstand tegen corrosie klasse 5 kan overwogen worden indien de inspectie en het onderhoud van het hang- en sluitwerk door de gebruiker niet eenvoudig kan gebeuren

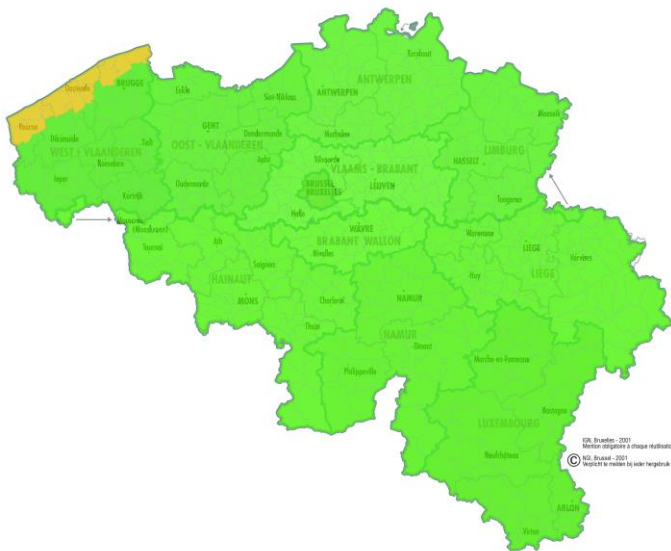

Fig. 1: Geografische agressiviteitszones

Ongeacht het klimaattype moet steeds onderzocht worden of er sprake is van plaatselijke agressiviteitsniveaus:

- nabijheid van spoorverkeer (treinen of trams),
- nabijheid van luchthavens,
- industriële chlorideneerslag,
- de situatie in dichtbevolkte stedelijke zones,
- plaatselijk verhoogde inwerking van vervuiling (aanwezigheid van bouwwerf, ...),
- minder of gebrek aan reiniging van het schrijnwerk door natuurlijke beregening veroorzaakt door het gevelreliëf, verborgen hoeken of andere situaties,
- binnenklimaten zoals zwembaden (afhankelijk van de waterbehandeling), composthal, opslag van corrosieve producten,
- nabijheid van intensieve veeteelt

8.1.2.1 Geanodiseerde profielen

De anodisatie voldoet aan de Qualanod kwaliteitsnormen en de uitvoerders ervan zijn door Estal (Estal Belgium VZW, Chemin des Soeurs 7, B-1320 Beauvechain – info@estal.be) gecertificeerd.

Geanodiseerde profielen worden aangeboden in twee kwaliteiten:

- a. Anodisatieprocedé 20 µm

De voorbehandeling bestaat uit ontvetten en chemisch afbijten, waarna het profiel wordt geanodiseerd en verdicht, tot een gemiddelde laagdikte van 20 µm. Plaatselijk kan de laagdikte 16 µm dik zijn.

- b. Anodisatieprocedé 25 µm

De voorbehandeling bestaat uit ontvetten en chemisch afbijten, waarna het profiel wordt geanodiseerd en verdicht, tot een gemiddelde laagdikte van 25 µm. Plaatselijk kan de laagdikte 20 µm dik zijn.

Het geanodiseerde oppervlak is natuurkleurig of elektrolytisch gekleurd (bij voorbeeld zwart of bronskleurig); een staalkaart kan bekomen worden bij de goedkeuringshouder en de schrijnwerkfabrikant.

8.1.2.2 Gelakte profielen

Het lakken voldoet aan de Qualicoat kwaliteitsnormen en de uitvoerders ervan is door Estal gecertificeerd.

Gelakte profielen worden aangeboden in twee kwaliteiten:

- a. Standaard lakprocedé

De voorbehandeling van de profielen gebeurt door:

- Beitsen (1 gr/m²), of
- Beitsen (1 gr/m²) en het aanbrengen van een conversielaag

De laklaag wordt daarop aangebracht in één behandeling.

- b. "Seaside" lakprocedé

De voorbehandeling van de profielen gebeurt door beitsen (2 gr/m²) en het aanbrengen van een conversielaag. De laklaag wordt daarop aangebracht in twee behandelingen.

Het gelakte oppervlak kan worden uitgevoerd in een reeks kleuren, glansgraden en texturen; een staalkaart kan bekomen worden bij de goedkeuringshouder en de schrijnwerkfabrikant.

8.2 Prestaties van de vensters

In functie van de luchtdoorlatendheid, waterdichtheid en windweerstand, de bedieningskrachten, de weerstand tegen verkeerd gebruik, de weerstand tegen herhaald gebruik, mogen de verschillende vensters voor de gegeven types gebouwen worden aangewend conform onderstaande tabel.

Tabel 11 – Geschiktheid van vensters in functie van de ruwheidsklasse van het terrein en het te verwachten gebruik

	Vaste vensters	Vensters met één vleugel		Stolpvensters	Samengestelde vensters
Openingswijze	—	<ul style="list-style-type: none"> – Binnendraaiend – Kippend – Kippend-binnendraaiend 	Buitendraaiend	<ul style="list-style-type: none"> – Primaire vleugel draaiend, – kippend, of kippend-draaiend – Secundaire vleugel draaiend 	— ⁽¹⁾
Hang- en sluitwerk	—	<ul style="list-style-type: none"> – Sobinco Chrono + en Chrono Safe – Fapim Galipius 2 – Roto NT Designo – Savio Ribanta Incanto 	Sobinco meerpuntslot	<ul style="list-style-type: none"> – Sobinco Chrono + – Roto NT Designo 	— ⁽¹⁾

Ruwheidsklasse van het terrein	Plaatsingshoogte vanaf het maaiveld van vensters volgens de regels voorzien in NBN B 25-002-1 § 5.2.2.1				
Zee (klasse I)	≤ 50 m	≤ 50 m	≤ 50 m		≤ 50 m
Platteland (klasse II)	≤ 50 m	≤ 50 m	≤ 50 m		≤ 50 m
Bos (klasse III)	≤ 50 m	≤ 50 m	≤ 50 m		≤ 50 m
Stad (klasse IV)	≤ 50 m	≤ 50 m	≤ 50 m		≤ 50 m

Toepasbaarheid in functie van:	Toepasbaarheid volgens de regels voorzien in NBN B 25-002-1 en prSTS 52.2				
de fysieke capaciteiten van de gebruiker (zie NBN B 25-002-1 § 5.2.2.2)	voor alle toepassingen (evaluatie is niet onderscheidend)	voor alle normale toepassingen			
het te verwachten verkeerd gebruik (zie NBN B 25-002-1 § 5.2.2.2)	voor alle toepassingen (evaluatie is niet onderscheidend)	intensief gebruik, scholen, openbare plaatsen			
de te verwachten gebruiksfrequentie (zie NBN B 25-002-1 § 5.2.2.11)	voor alle toepassingen (evaluatie is niet onderscheidend)	eengezinswoning, administratieve gebouwen niet rechtstreeks toegankelijk voor het publiek en alle plaatsen waar normale duurzaamheid wordt verwacht			
de vereiste weerstand tegen schokken (zie NBN B 25-002-1 § 5.2.2.10)	Alle toepassingen ⁽²⁾	Alle residentiële toepassingen en kantoren die buiten niet publiek toegankelijk zijn ⁽²⁾	niet bepaald		⁽¹⁾
de vereiste weerstand tegen inbraak (zie NBN B 25-002-1 § 5.2.2.5)	niet bepaald	Klasse RC2 ⁽³⁾ (enkel Sobinco Chrono Safe)	niet bepaald	niet bepaald	⁽¹⁾
de weerstand tegen corrosie (zie prSTS 52.2 § 4.2.1)	zones I tot en met IV				
⁽¹⁾ :	de vermelde prestatie dient te worden beperkt tot de eigenschappen van de vensters die in de samenstelling worden gebruikt				
⁽²⁾ :	indien deze eigenschap gevraagd is, moet het glas minstens van de samenstellingen 44.2 zijn langs de kant waar de schok wordt verwacht en moeten de glaslatten van het tubulaire type zijn				
⁽³⁾ :	indien deze eigenschap gevraagd is, moet het glas minstens van het type P4A volgens NBN EN 356 zijn en moeten de glaslatten van het tubulaire type zijn				

8.3 Gereglementeerde stoffen

De goedkeuringshouder verklaart conform te zijn aan de Europese verordening (EG) nr. 1907/2006 van het Europees parlement en de raad van 18 december 2006) inzake de registratie en beoordeling van en de autorisatie en beperkingen ten aanzien van chemische stoffen (REACH) voor de elementen van het systeem die door de goedkeuringshouder worden aangeleverd.

Zie: http://economie.fgov.be/nl/ondernemingen/specifieke_domeinen/chemie/REACH/index.jsp.

8.4 Akoestische prestaties

Een venster met onderstaande opbouw werd beproefd volgens de normen NBN EN ISO 717-1; de resultaten kunnen gebruikt worden voor het vergelijken van verschillende types vensters of beglazingen.

Tabel 12 – Akoestische prestaties

Venstertype	Draaikip venster
Vast profiel	P-03-101
Vleugel profiel	P-03-200
Middendichting	A-GS-135 + 136
Aanslagdichting binnen/buiten	A-GS-131
Glasdichting binnen/buiten	EPDM
Beslag	2 rotatiepunten, 4 sluitpunten (Fapim)
Sluitkracht	≤ 14 Nm
Breedte x hoogte	1230 mm x 1480 mm
Beglazing	44.2/12(Ar)/6
Prestaties beglazing R _w (C; C _{tr})	38 (-1;-5) dB
Prestaties venster R _w (C; C _{tr})	40 (-2;-6) dB

8.5 Inbraakwerendheid

Een venster uit de reeks Blyweert Apollo werd beproefd volgens de norm NBN ENV 1627. Op basis hiervan verklaart het laboratorium dat deze proeven uitvoerde, conform de vermelde norm, dat vensters met onderstaande onderdelen, over de vermelde inbraakwerendheid beschikken.

Tabel 13 – Prestaties Inbraakwerendheid – deuren

Venstertype	Draai- of draaikip (binnendraaiend)
Vast profiel	Alle vermelde kaderprofielen
Vleugel profiel	Alle vermelde vleugelprofielen
Makelaar	-
Stijlen of dwarsregels	-
Middendichting	Alle vermelde middendichtingen
Aanslagdichting binnen/buiten	Alle vermelde aanslagdichtingen
Glasdichting binnen/buiten	Alle vermelde glasdichtingen
Glaslatten	Enkel tubulaire glaslatten
Beslag	Sobinco Chrono Safe
Aantal scharnieren	2 of meer, volgens beslagdiagramma
Aantal sluitpunten	4 of meer, volgens beslagdiagramma
Breedte x hoogte	tot 1416 mm x 2136 mm
Beglazing	P4 A
Prestaties venster volgens NBN ENV 1627	WK2

8.6 Weerstand tegen schokken

Een twee vensters met onderstaande opbouw werden beproefd volgens de norm NBN EN 13049.

Tabel 14 – Prestaties weerstand tegen schokken

Venstertype	Draai-kip venster	Samengesteld venster
Vast profiel	P-03-101	P-03-100
Vleugel profiel	P-00-702	P-00-200
Makelaar	-	P-03-400
Stijl of dwarsregel	-	P-03-300
Middendichting	A-GS-135	A-GS-135
Aanslagdichting binnen/buiten	A-GS-131/-	A-GS-131/-
Glasdichting binnen/buiten	A-GS-305/ A-GS-100	A-GS-305/ A-GS-100
Glaslatten	Tubulair	tubulair
Beslag	Fapim 2 scharnieren 4 sluitpunten	Sobinco Chrono
Breedte x hoogte	1230 mm x 1480 mm	2000 mm x 2200 mm
Beglazing	6/15/44.2	6/15/6
Gewicht	50 kg	52 kg
Prestaties	Klasse 5 (valhoogte: 950 mm)	Klasse 3 (valhoogte: 450 mm)

8.7 Overige eigenschappen

8.7.1 Weerstand tegen sneeuwbelasting

De weerstand tegen sneeuwbelasting en permanente belasting van een venster werd niet bepaald. Voor een venster die verticaal staat opgesteld, is deze eigenschap niet relevant. Het venster beschikt bijgevolg niet over een classificatie betreffende de weerstand tegen sneeuwbelasting en permanente belasting.

8.7.2 Brandreactie

De brandreactie van een venster werd niet bepaald. Vensters met een gegeven brandreactie vormen het onderwerp van een apart Benor/ATG onderzoek.

8.7.3 Gedrag bij blootstelling aan externe brand

Het gedrag bij blootstelling aan externe brand van een venster werd niet bepaald. Vensters en d met een gegeven gedrag bij blootstelling aan externe brand vormen het onderwerp van een apart Benor/ATG onderzoek.

8.7.4 Ontgrendelingsmogelijkheid

De ontgrendelingsmogelijkheid van een deur werd niet bepaald. Voor vensters is deze eigenschap niet relevant. Deuren met een gegeven ontgrendelingsmogelijkheid (anti-paniekdeuren) vormen het onderwerp van een apart Benor/ATG onderzoek.

8.7.5 Stralingseigenschappen

De stralingseigenschappen van het venster zijn deze van het in het venster te monteren invulpaneel.

Indien het venster niet van transparante beglazing is voorzien, geldt voor de zontoetredingsfactor "g" en de lichtdoorlatendheid "t_v" van het venster dat g = 0 en t_v = 0.

8.7.6 Duurzaamheid

De duurzaamheid van ramen hangt af van de prestaties op lange termijn van de individuele componenten en materialen alsook van de montage van het product en het onderhoud ervan.

De in de goedkeuring opgenomen beschrijving, evenals de documenten waarnaar verwezen wordt, geven een volledige beschrijving van de onderdelen, hun afwerking en het nodige onderhoud.

De goedkeuringshouder verzekert door de keuze van materialen (inclusief bekleding, bescherming, samenstelling en dikte), componenten en montagethodes de duurzaamheid van zijn product(en) voor een economisch redelijke levensduur, rekening houdend met de vermelde onderhoudsvorschriften.

8.7.7 Ventilatie

De ventilatie eigenschappen van het venster zijn deze van de in of aan het venster te monteren ventilatievoorziening.

Indien het venster niet van ventilatievoorzieningen is voorzien, geldt voor het luchtstroomkenmerk "K", de stromingsexponent "n" en het geometrisch vrij oppervlak "A" van het venster dat $K = 0$; n en A zijn niet bepaald.

8.7.8 Kogelweerstand

De kogelweerstand van een venster werd niet bepaald. Het venster beschikt bijgevolg niet over een classificatie betreffende de kogelweerstand.

8.7.9 Explosieweerstand

De explosieweerstand van een venster werd niet bepaald. Het venster beschikt bijgevolg niet over een classificatie betreffende de explosieweerstand.

8.7.10 Weerstand tegen herhaald openen en sluiten

De weerstand tegen herhaald openen en sluiten van een venster werd niet bepaald. Er mag worden verondersteld dat de duurzaamheid van het beslag richtinggevend is.

8.7.11 Gedrag tussen verschillende klimaten

Het gedrag tussen verschillende klimaten van een venster werd niet bepaald.

Voor transparant beglaasde vensters wordt aangenomen dat zij geschikt zijn om te worden blootgesteld aan intensieve zonnestraling en grote temperatuurverschillen. Dit geldt niet voor vensters die worden voorzien van een niet transparant invulpaneel.

9 Voorwaarden

- A. Uitsluitend het in de voorpagina als houder vermelde bedrijf en het bedrijf (de bedrijven) die het onderwerp van de goedkeuring commercialiseert (commercialiseren) mogen aanspraak maken op de toepassing van deze technische goedkeuring.
- B. Deze technische goedkeuring heeft uitsluitend betrekking op het product of systeem waarvan de handelsnaam op de voorpagina wordt vermeld. Houders van een technische goedkeuring mogen geen gebruik maken van de naam van de BUTgb, haar logo, het merk ATG, de goedkeuringstekst of het goedkeuringsnummer om aanspraak te maken op productbeoordelingen die niet in overeenstemming zijn met de technische goedkeuring, en evenmin voor producten en/of systemen en/of eigenschappen of kenmerken die niet het voorwerp uitmaken van de technische goedkeuring.
- C. Informatie die door de goedkeuringshouder of zijn aangestelde en/of erkende installateurs, op welke wijze dan ook, ter beschikking wordt gesteld van (potentiële) gebruikers van het in de technische goedkeuring behandelde product of systeem (bv. Bouwheren, aannemers, voorschrijvers, ...), mag niet in tegenstrijd zijn met de inhoud van de goedkeuringstekst, noch met informatie waarnaar in de goedkeuringstekst verwezen wordt.
- D. Houders van een technische goedkeuring zijn steeds verplicht tijdig eventuele aanpassingen aan de grondstoffen en producten, de verwerkingsrichtlijnen, het productie- en verwerkingsproces en/of de uitrusting, voorafgaandelijk bekend te maken aan de BUTgb vzw, en de door de BUTgb aangeduide certificatieoperator, zodat deze kan oordelen of de technische goedkeuring dient te worden aangepast.
- E. De auteursrechten behoren tot de Butgb

Fig. 2: Uitvoeringsvarianten

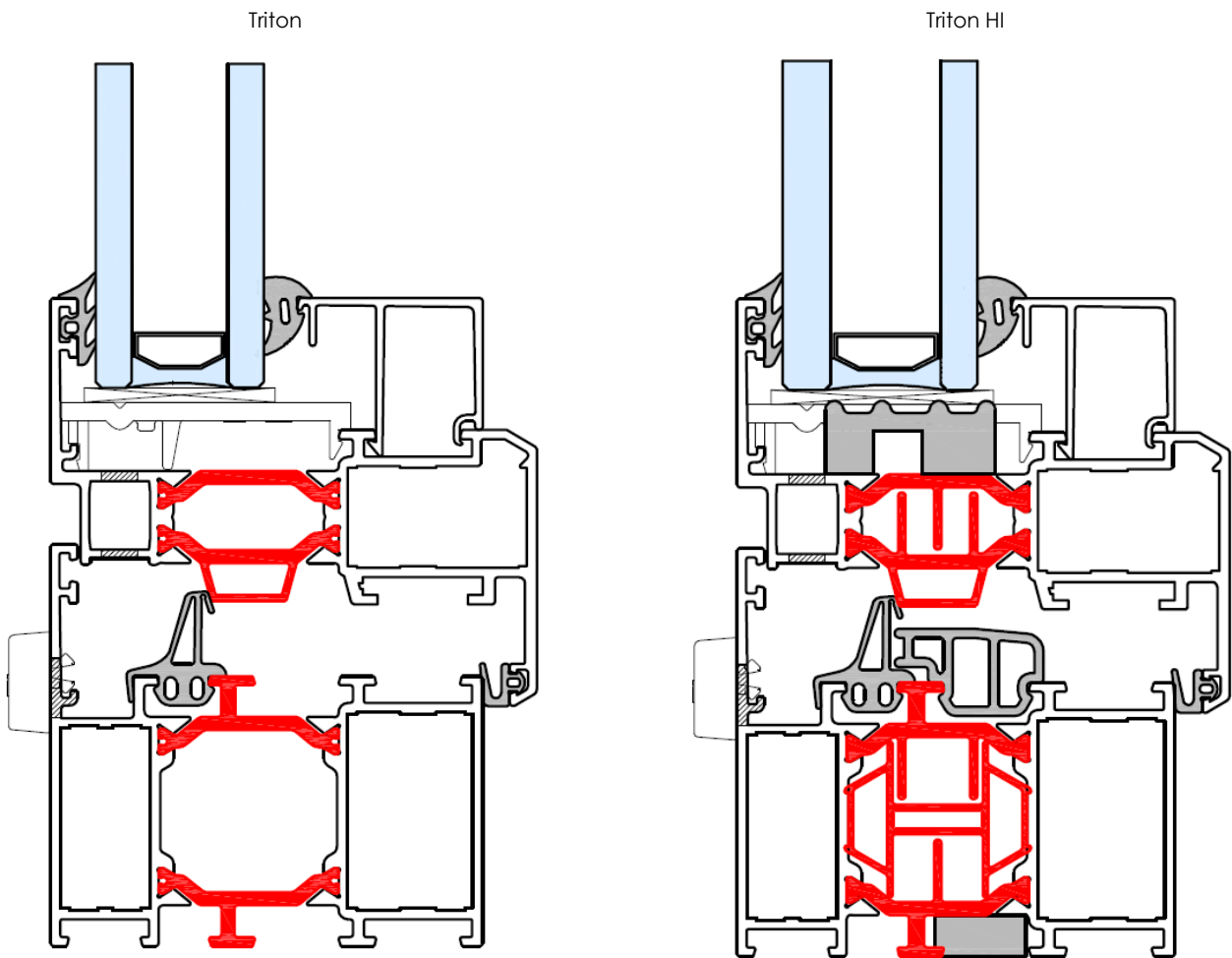

Fig. 3: Typesnede vast venster

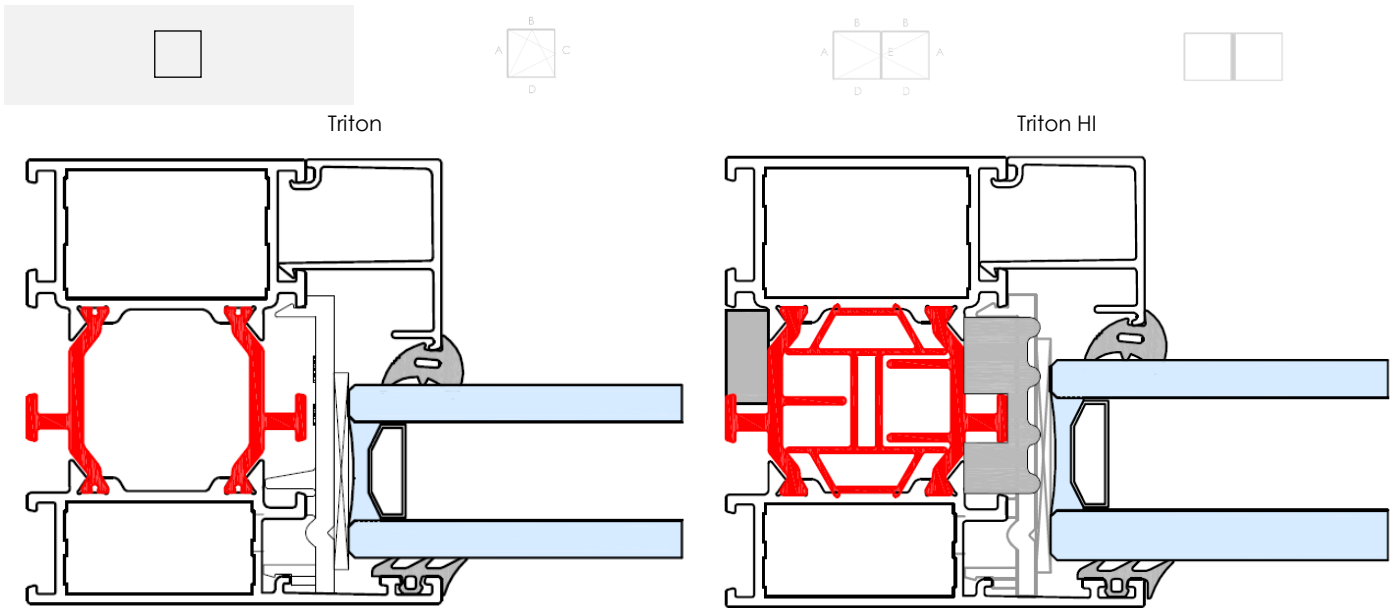

Fig. 4: Typesnede draai-kip venster

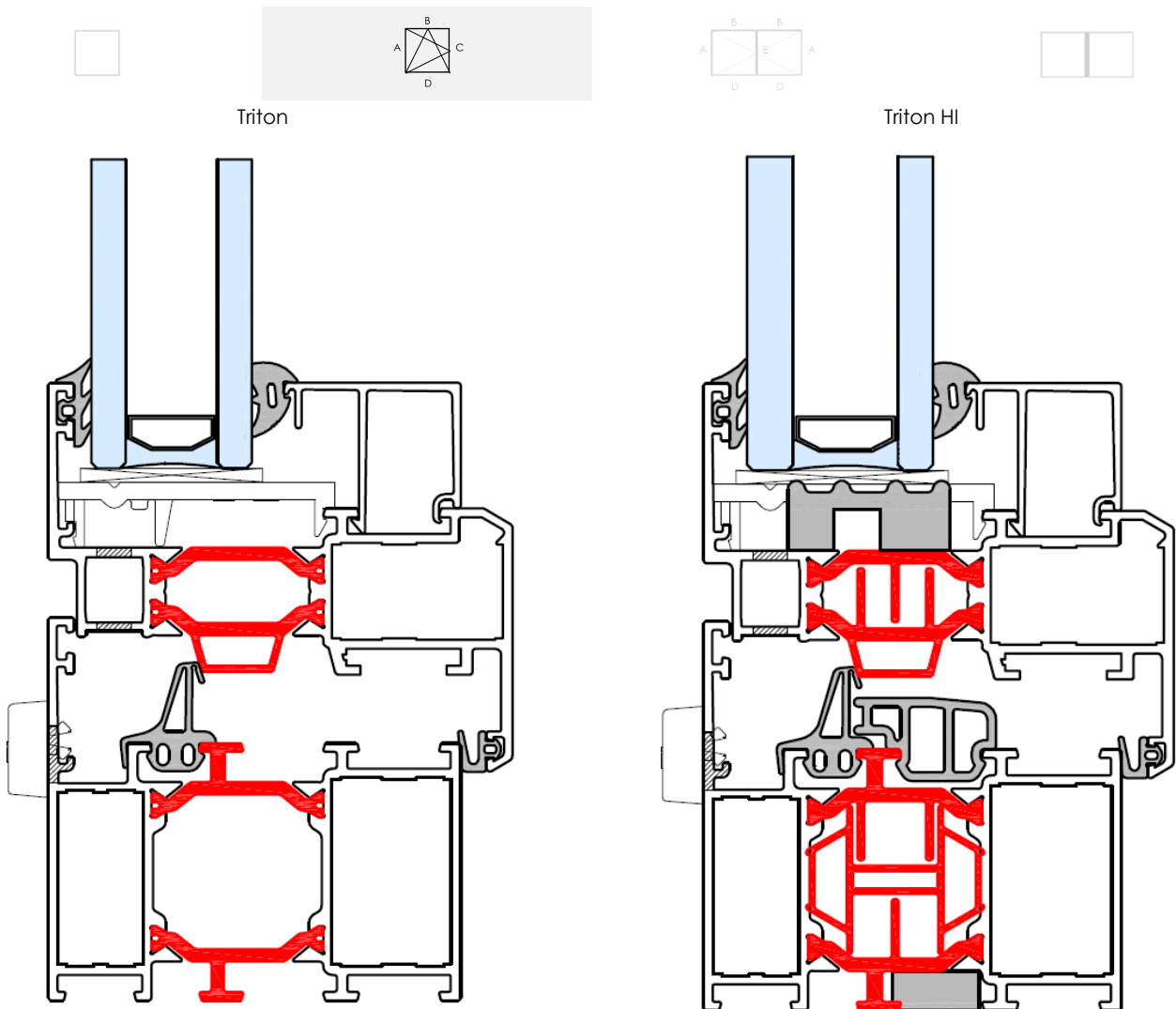
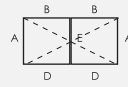
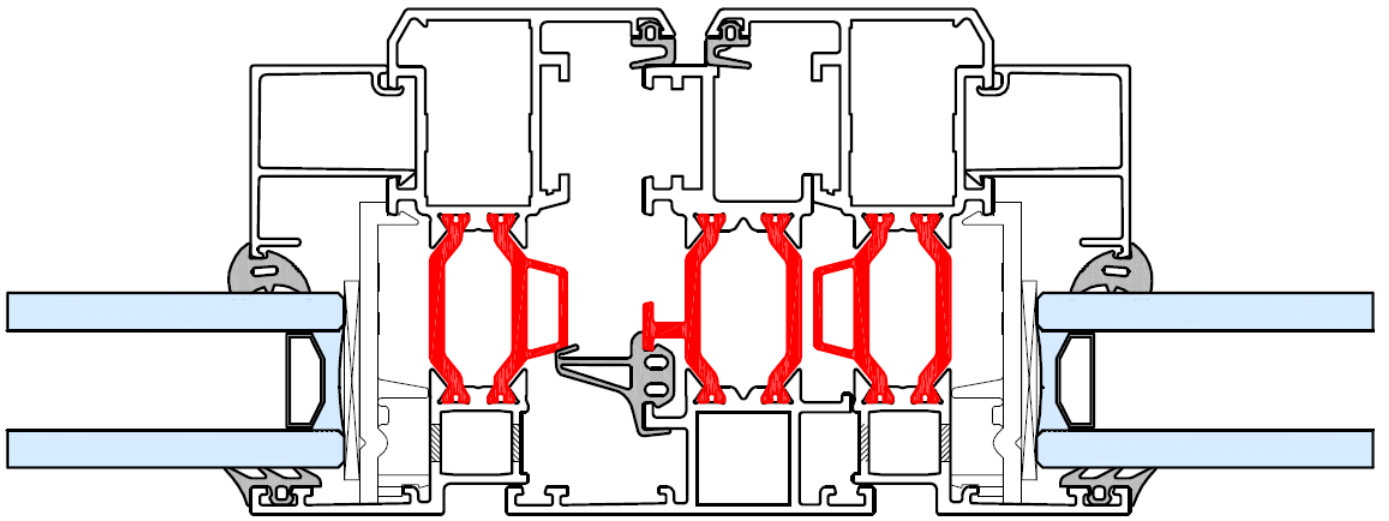

Fig. 5: Typesnede stolp venster



Triton



Triton HI

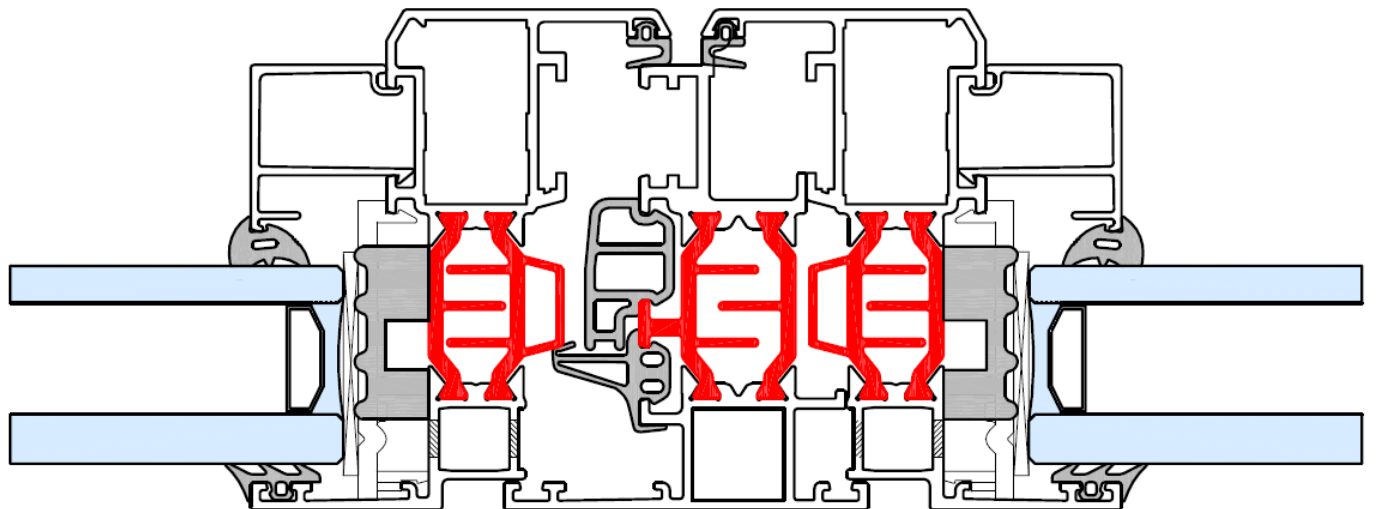
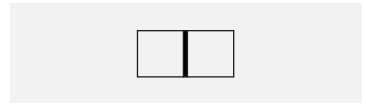
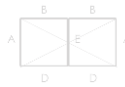
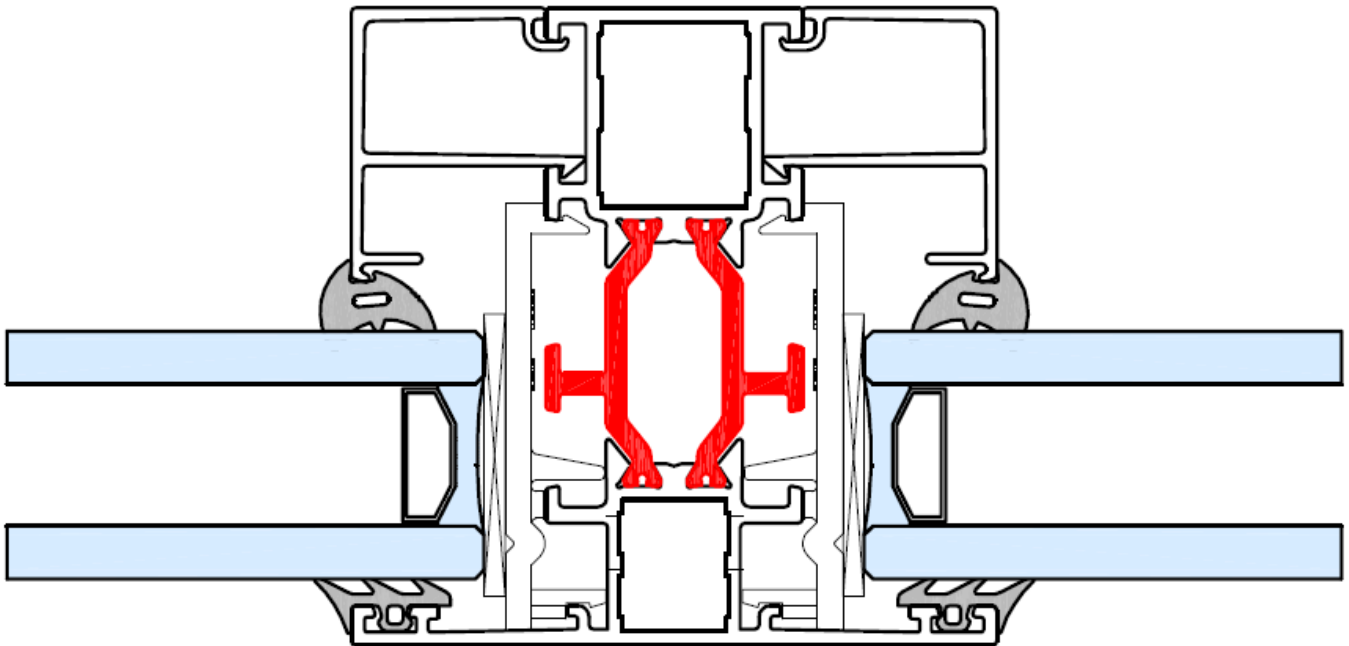

Fig. 6: Typesnede samengesteld venster



Triton



Triton HI

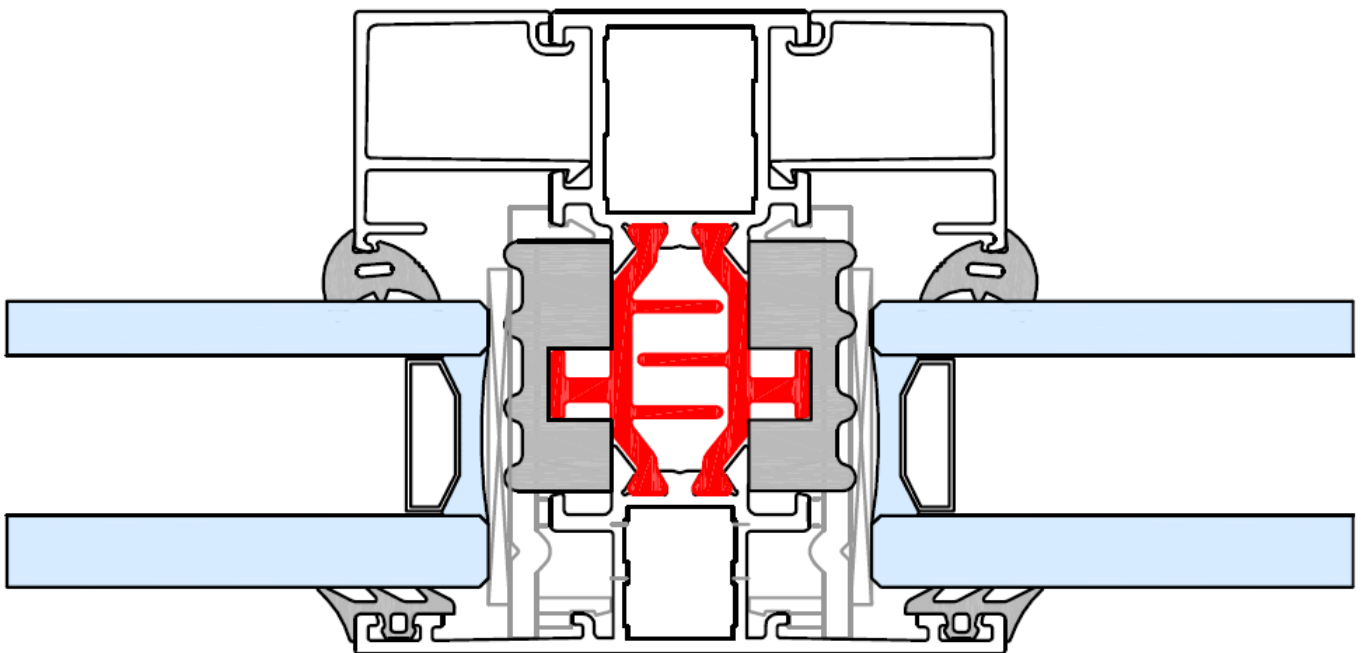

Fiche "Bijlage 1" – Vast schrijnwerk

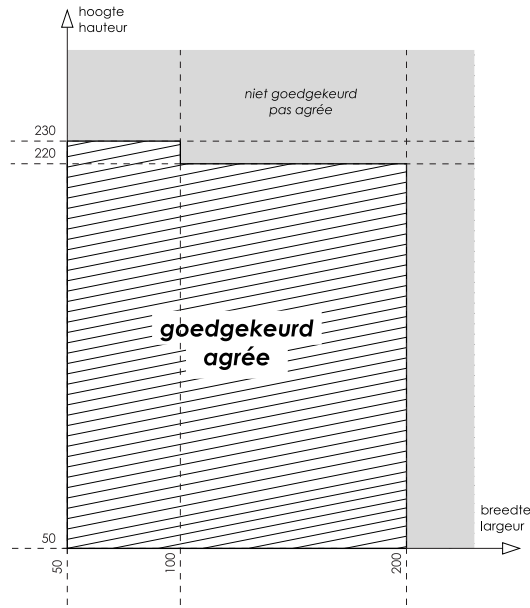
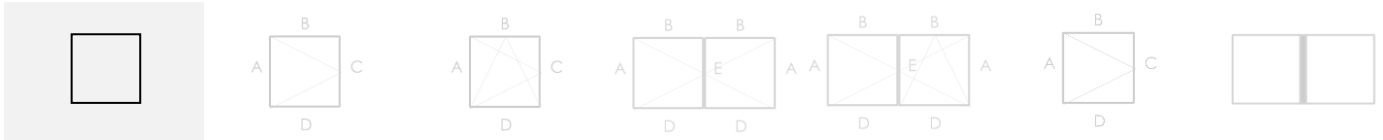

Eigenschappen van de vensters cf. NBN EN 14351-1

		Vaste vensters
Openingswijze		Niet van toepassing
4.2	Weerstand tegen windbelasting	C4
4.3	Weerstand tegen sneeuwbelasting	Niet bepaald, zie paragraaf 8.7.1
4.4.1	Brandreactie	Niet bepaald, zie paragraaf 8.7.2
4.4.2	Gedrag bij blootstelling aan externe brand	Niet bepaald, zie paragraaf 8.7.3
4.5	Waterdichtheid	E750A
4.6	Gevaarlijke substanties	Zie paragraaf 8.3
4.7	Schokweerstand	Klasse 5 ⁽²⁾
4.8	Weerstandsvormogen van de veiligheidsvoorzieningen	Niet van toepassing
4.11	Akoestische prestaties	Zie paragraaf 8.4
4.12	Warmtedoorgangscoefficient	Zie paragraaf 8.1.1
4.13	Stralingseigenschappen	Zie de declaratie van de fabrikant van de beglazing, zie paragraaf 8.7.5
4.14	Luchtdoorlatendheid	4
4.15	Duurzaamheid	Voldoet, zie paragraaf 8.7.6
4.16	Bedieningskrachten	Niet van toepassing
4.17	Mechanische weerstand	Niet van toepassing
4.18	Ventilatie	Zie de declaratie van de fabrikant van de verluchttingsvoorzieningen, zie paragraaf 8.7.7
4.19	Kogelweerstand	Niet bepaald, zie paragraaf 8.7.8
4.20	Explosieweerstand	Niet bepaald, zie paragraaf 8.7.9
4.21	Weerstand tegen herhaald openen en sluiten	Niet van toepassing
4.22	Gedrag tussen verschillende klimaten	Niet bepaald, zie paragraaf 8.7.11
4.23	Inbraakwerendheid	Klasse RC2 ⁽³⁾
⁽²⁾ :	indien deze eigenschap gevraagd is, moet het glas minstens van de samenstellingen 44.2 zijn langs de kant waar de schok wordt verwacht en moeten de glaslatten van het tubulaire type zijn	
⁽³⁾ :	indien deze eigenschap gevraagd is, moet het glas minstens van het type P4A volgens NBN EN 356 zijn en moeten de glaslatten van het tubulaire type zijn	

Fiche "Bijlage 2a" – Hang- en sluitwerk "Sobinco Chrono"

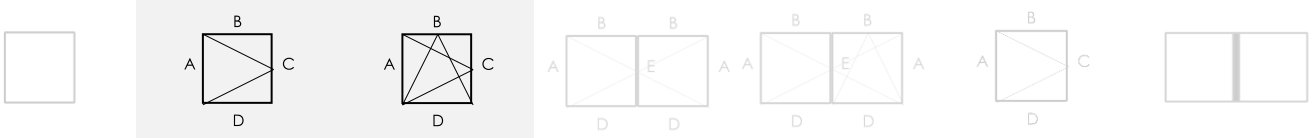

Eigenschappen van het hang- en sluitwerk cf. NBN EN 13126-8

Gebruiks-categorie	Duurzaamheid	Gewicht	Brandweerstand	Gebruiksveiligheid	Corrosieweerstand	Veiligheid	Normdeel	Proefmaat
—	4	130	0	1	4	—	8	1300 x 1200

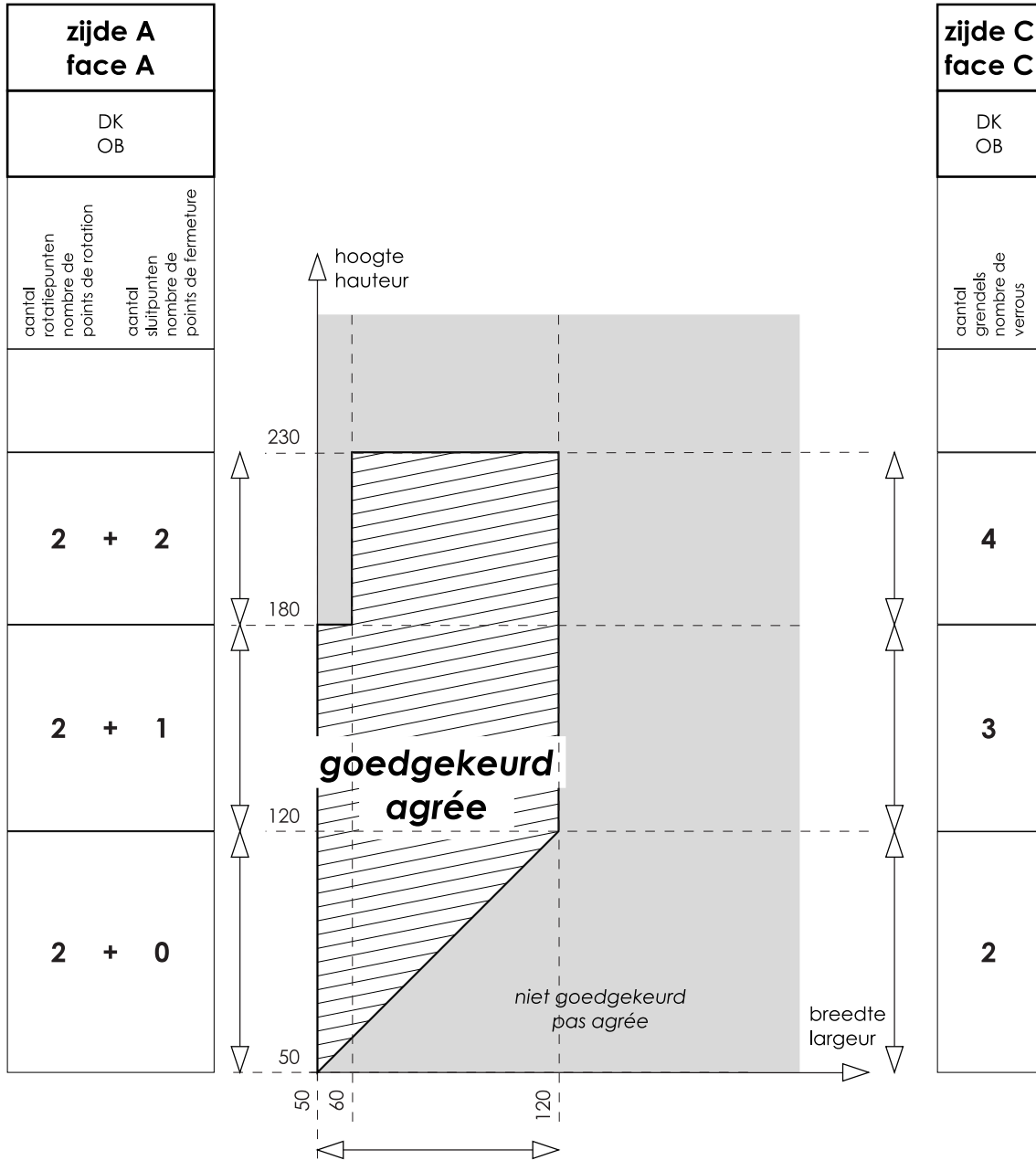

De vleugel met het hoogste gewicht welke beproefd werd, woog 65 kg.

Fiche "Bijlage 2a" (vervolg) – Hang- en sluitwerk "Sobinco Chrono"

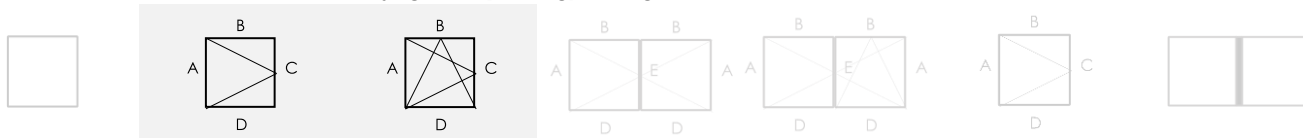

Eigenschappen van de vensters cf. NBN EN 14351-1

		Vensters met één vleugel
Openingswijze		<ul style="list-style-type: none"> - Draaiend - Kippend - Kippend-draaiend
4.2	Weerstand tegen windbelasting	C4
4.3	Weerstand tegen sneeuwbelasting	Niet bepaald, zie paragraaf 8.7.1
4.4.1	Brandreactie	Niet bepaald, zie paragraaf 8.7.2
4.4.2	Gedrag bij blootstelling aan externe brand	Niet bepaald, zie paragraaf 8.7.3
4.5	Waterdichtheid	E _{1,650A}
4.6	Gevaarlijke substanties	Zie paragraaf 8.3
4.7	Schokweerstand (proef met zacht lichaam)	Klasse 4 ⁽²⁾
4.8	Weerstandvermogen van de veiligheidsvoorzieningen	Niet van toepassing
4.11	Akoestische prestaties	Zie paragraaf 8.4
4.12	Warmtedoorgangscoëfficiënt	Zie paragraaf 8.1.1
4.13	Stralingseigenschappen	Zie de declaratie van de fabrikant van de beglazing, zie paragraaf 8.7.5
4.14	Luchtdoorlatendheid	4
4.15	Duurzaamheid	Voldoet, zie paragraaf 8.7.6
4.16	Bedieningskrachten	1
4.17	Mechanische weerstand	4
4.18	Ventilatie	Zie de declaratie van de fabrikant van de verluchttingsvoorzieningen, zie paragraaf 8.7.7
4.19	Kogelweerstand	Niet bepaald, zie paragraaf 8.7.8
4.20	Explosie-weerstand	Niet bepaald, zie paragraaf 8.7.9
4.21	Weerstand tegen herhaald openen en sluiten	Niet bepaald, zie paragraaf 8.7.10 (hang- en sluitwerk: 15.000 cycli)
4.22	Gedrag tussen verschillende klimaten	Niet bepaald, zie paragraaf 8.7.11
4.23	Inbraakwerendheid	Klasse RC2 ⁽³⁾ (Sobinco Chrono Safe)
⁽²⁾ :	indien deze eigenschap gevraagd is, moet het glas minstens van de samenstellingen 44.2 zijn langs de kant waar de schok wordt verwacht en moeten de glaslatten van het tubulaire type zijn	
⁽³⁾ :	indien deze eigenschap gevraagd is, moet het glas minstens van het type P4A volgens NBN EN 356 zijn en moeten de glaslatten van het tubulaire type zijn	

Fiche "Bijlage 2b" – Hang- en sluitwerk "Sobinco Chrono"

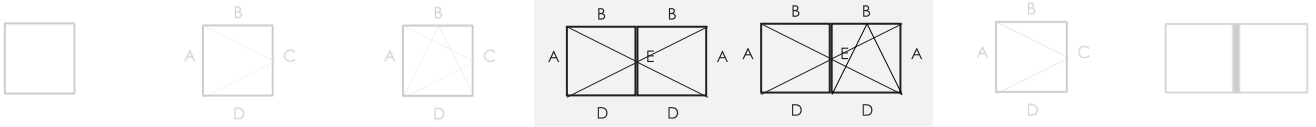

Eigenschappen van het hang- en sluitwerk cf. NBN EN 13126-8

Gebruiks-categorie	Duurzaam-hed	Gewicht	Brand-weerstand	Gebruiks-veiligheid	Corrosie-weerstand	Veiligheid	Normdeel	Proefmaat
—	4	130	0	1	4	—	8	1300 x 1200

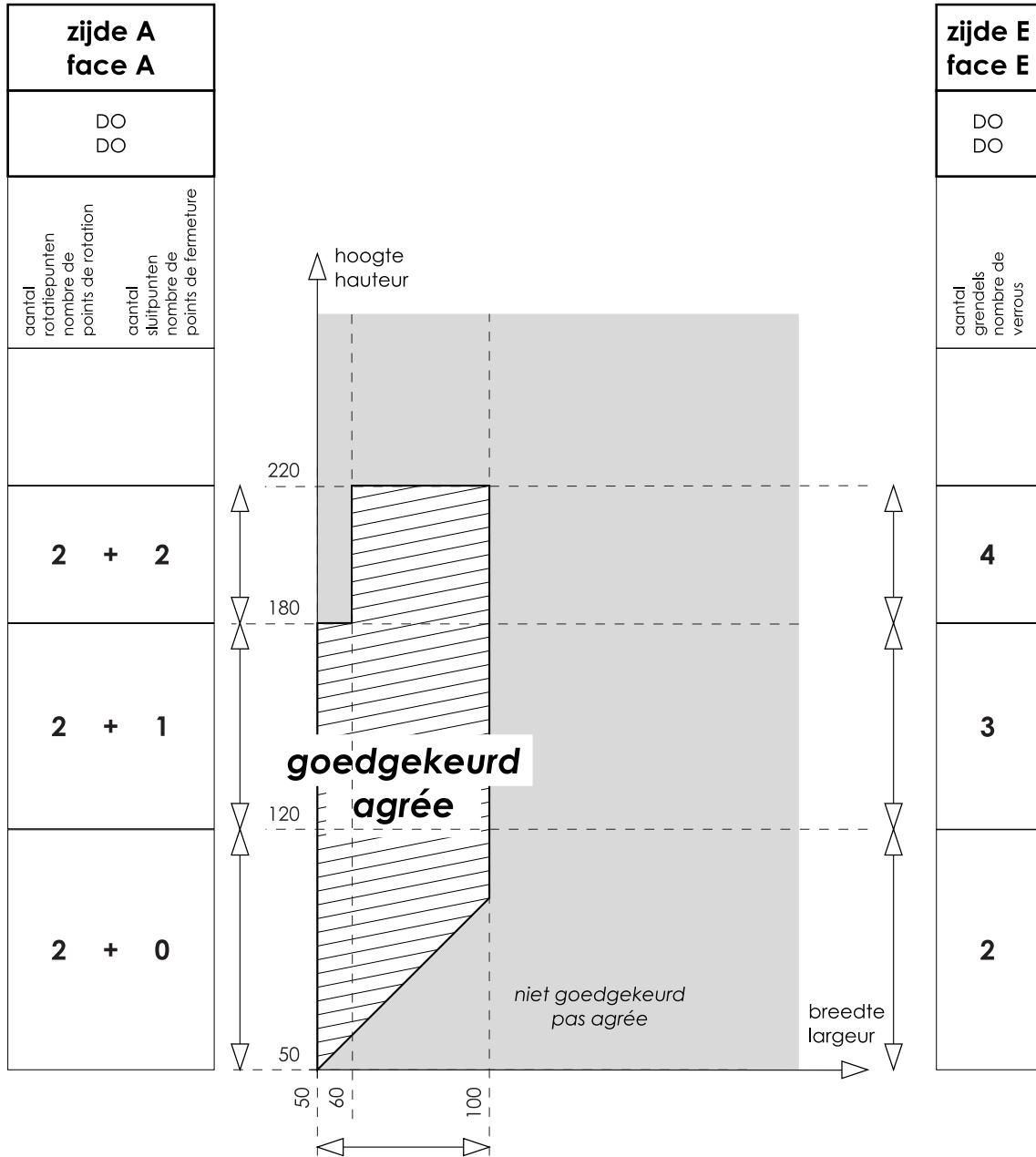

zijden B + D faces B + D	DO DO	0		aantal sluitpunten nombre de points de fermeture
-------------------------------------	----------	----------	--	---

De vleugel met het hoogste gewicht welke beproefd werd, woog 61 kg.

Fiche "Bijlage 2b" (vervolg) – Hang- en sluitwerk "Sobinco Chrono"

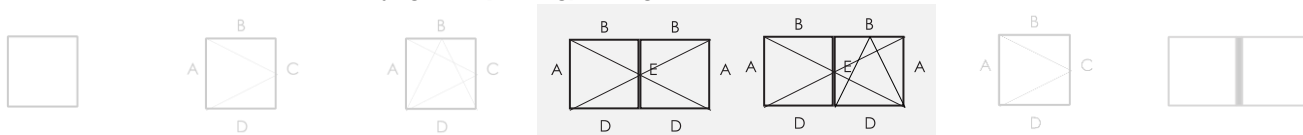

Eigenschappen van de vensters cf. NBN EN 14351-1

		Vensters met twee vleugels
Openingswijze		Primaire vleugel – draaiend, – kippend, of – kippend-draaiend Secundaire vleugel – draaiend
4.2	Weerstand tegen windbelasting	C3
4.3	Weerstand tegen sneeuwbelasting	Niet bepaald, zie paragraaf 8.7.1
4.4.1	Brandreactie	Niet bepaald, zie paragraaf 8.7.2
4.4.2	Gedrag bij blootstelling aan externe brand	Niet bepaald, zie paragraaf 8.7.3
4.5	Waterdichtheid	E _{750A}
4.6	Gevaarlijke substanties	Zie paragraaf 8.3
4.7	Schokweerstand (proef met zacht lichaam)	Klasse 3 ⁽²⁾
4.8	Weerstandsvermogen van de veiligheidsvoorzieningen	Niet van toepassing
4.11	Akoestische prestaties	Zie paragraaf 8.4
4.12	Warmtedoorgangscoëfficiënt	Zie paragraaf 8.1.1
4.13	Stralingseigenschappen	Zie de declaratie van de fabrikant van de beglazing, zie paragraaf 8.7.5
4.14	Luchtdoorlatendheid	4
4.15	Duurzaamheid	Voldoet, zie paragraaf 8.7.6
4.16	Bedieningskrachten	1
4.17	Mechanische weerstand	4
4.18	Ventilatie	Zie de declaratie van de fabrikant van de verluchttingsvoorzieningen, zie paragraaf 8.7.7
4.19	Kogelweerstand	Niet bepaald, zie paragraaf 8.7.8
4.20	Explosie-weerstand	Niet bepaald, zie paragraaf 8.7.9
4.21	Weerstand tegen herhaald openen en sluiten	Niet bepaald, zie paragraaf 8.7.10 (hang- en sluitwerk: 15.000 cycli)
4.22	Gedrag tussen verschillende klimaten	Niet bepaald, zie paragraaf 8.7.11
	Inbraakwerendheid	Niet bepaald
⁽²⁾ : indien deze eigenschap gevraagd is, moet het glas minstens van de samenstellingen 44.2 zijn langs de kant waar de schok wordt verwacht en moeten de glaslatten van het tubulaire type zijn		

Fiche "Bijlage 3" – Hang- en sluitwerk "Savio Riba Incanto"

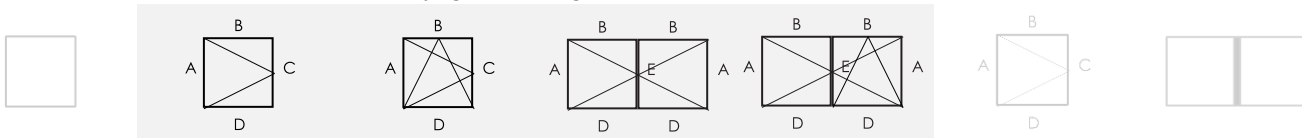

Eigenschappen van het hang- en sluitwerk cf. NBN EN 13126-8

Gebruiks-categorie	Duurzaamheid	Gewicht	Brand-weerstand	Gebruiks-veiligheid	Corrosie-weerstand	Veiligheid	Normdeel	Proefmaat
—	4	100	0	1	4	—	8	1300 x 1200

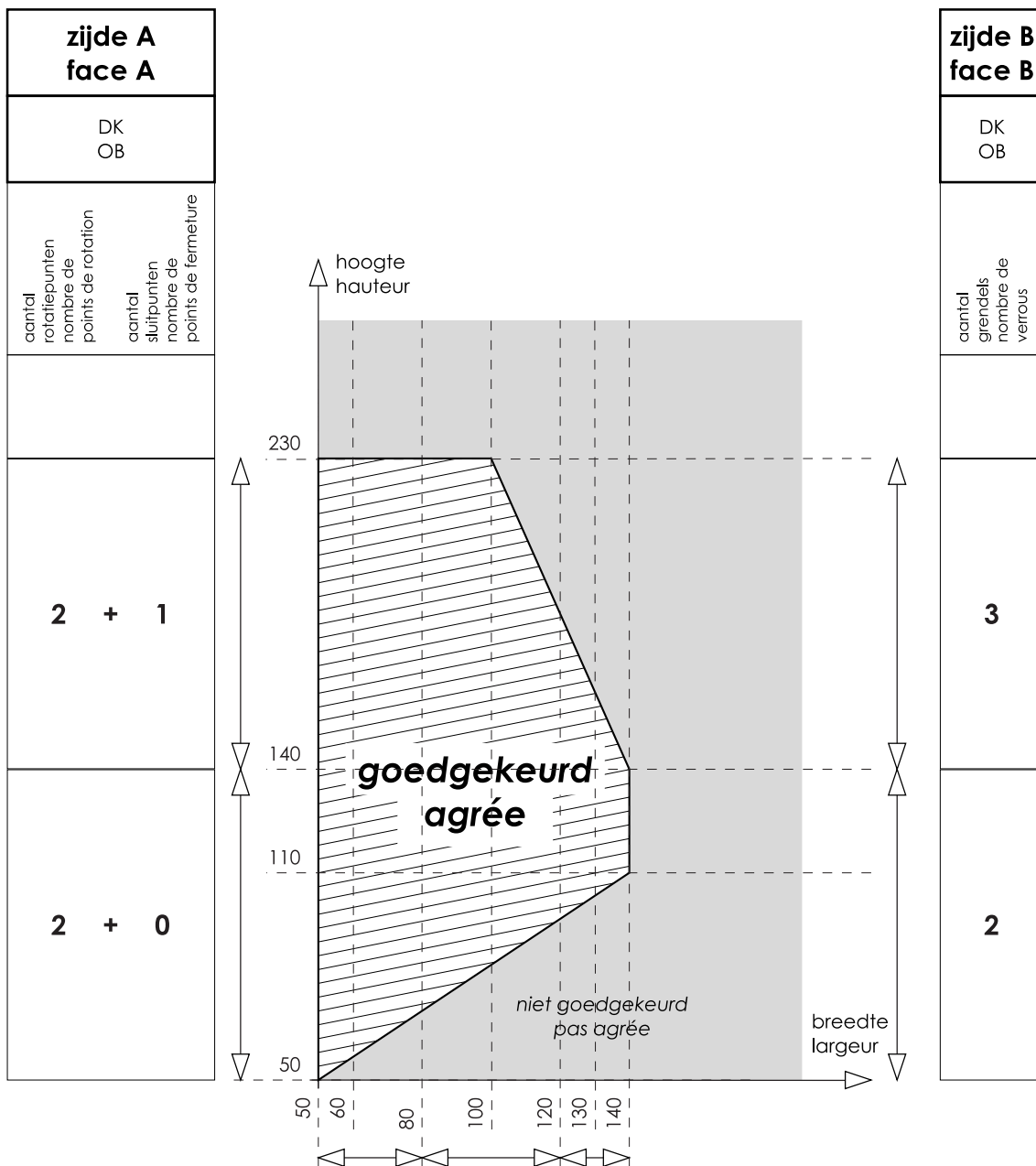

zijde B faces B	DK OB	0	1	2	aantal sluitpunten nombre de points de fermeture
zijde D face D	DK OB	0	1		aantal sluitpunten nombre de points de fermeture

De vleugel met het hoogste gewicht welke beproefd werd, woog 52 kg.

Fiche "Bijlage 3" (vervolg) – Hang- en sluitwerk "Savio Riba Incanto"

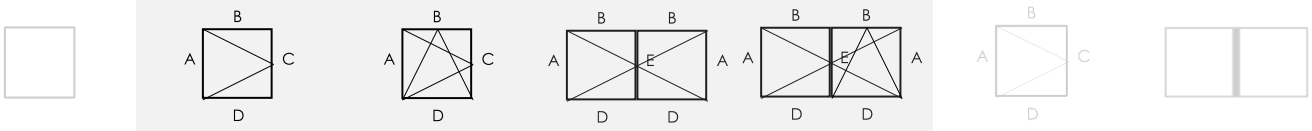

Eigenschappen van de vensters cf. NBN EN 14351-1

		Vensters met één vleugel
	Openingswijze	<ul style="list-style-type: none"> - Draaiend - Kippend - Kippend-draaiend
4.2	Weerstand tegen windbelasting	C4
4.3	Weerstand tegen sneeuwbelasting	Niet bepaald, zie paragraaf 8.7.1
4.4.1	Brandreactie	Niet bepaald, zie paragraaf 8.7.2
4.4.2	Gedrag bij blootstelling aan externe brand	Niet bepaald, zie paragraaf 8.7.3
4.5	Waterdichtheid	E _{1500A}
4.6	Gevaarlijke substanties	Zie paragraaf 8.3
4.7	Schokweerstand (proef met zacht lichaam)	Niet bepaald
4.8	Weerstandvermogen van de veiligheidsvoorzieningen	Niet van toepassing
4.11	Akoestische prestaties	Zie paragraaf 8.4
4.12	Warmtedoorgangscoëfficiënt	Zie paragraaf 8.1.1
4.13	Stralingseigenschappen	Zie de declaratie van de fabrikant van de beglazing, zie paragraaf 8.7.5
4.14	Luchtdoorlatendheid	4
4.15	Duurzaamheid	Voldoet, zie paragraaf 8.7.6
4.16	Bedieningskrachten	1
4.17	Mechanische weerstand	4
4.18	Ventilatie	Zie de declaratie van de fabrikant van de verluchttingsvoorzieningen, zie paragraaf 8.7.7
4.19	Kogelweerstand	Niet bepaald, zie paragraaf 8.7.8
4.20	Explosie-weerstand	Niet bepaald, zie paragraaf 8.7.9
4.21	Weerstand tegen herhaald openen en sluiten	Niet bepaald, zie paragraaf 8.7.10 (hang- en sluitwerk: 15.000 cycli)
4.22	Gedrag tussen verschillende klimaten	Niet bepaald, zie paragraaf 8.7.11
4.23	Inbraakwerendheid	Niet bepaald

Fiche "Bijlage 4" – Hang- en sluitwerk "Fapim Galipus 2"

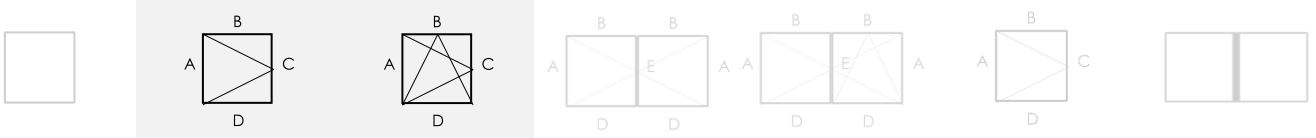

Eigenschappen van het hang- en sluitwerk cf. NBN EN 13126-8

Gebruiks-categorie	Duurzaamheid	Gewicht	Brand-weerstand	Gebruiks-veiligheid	Corrosie-weerstand	Veiligheid	Normdeel	Proefmaat
—	4	100	0	1	4	—	8	1300 x 1200

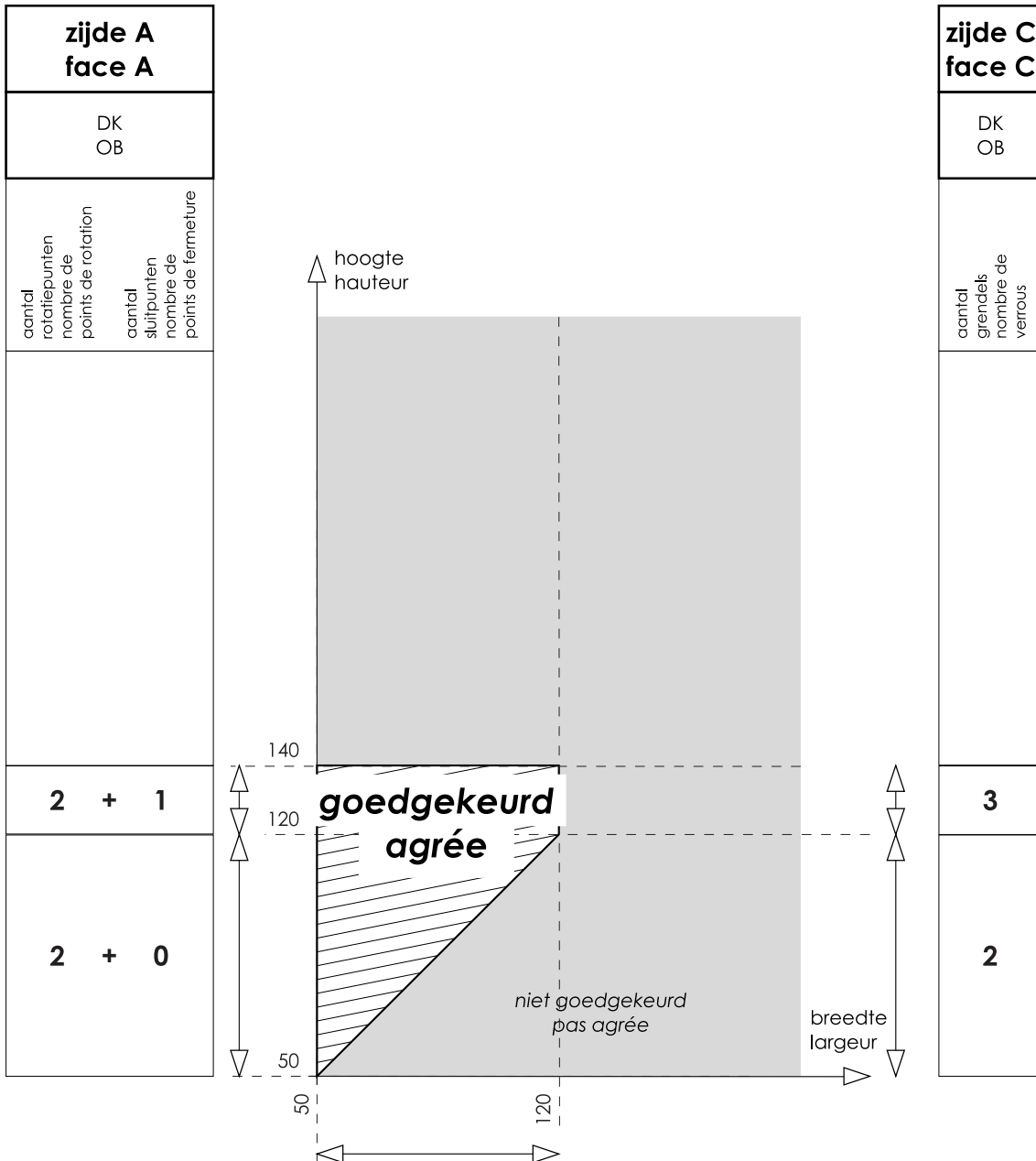

zijden B + D faces B + D	DK OB	0	aantal sluitpunten nombre de points de fermeture
-----------------------------	----------	---	---

De vleugel met het hoogste gewicht welke beproefd werd, woog 56 kg.

Fiche "Bijlage 4" (vervolg) – Hang- en sluitwerk "Fapim Galipius 2"

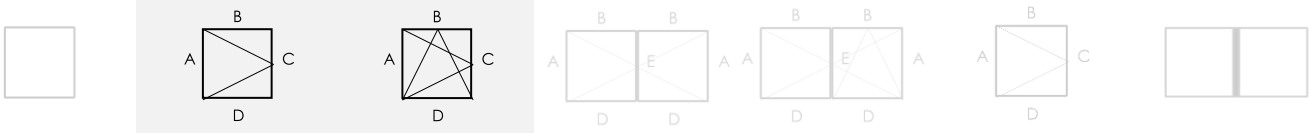

Eigenschappen van de vensters cf. NBN EN 14351-1

		Vensters met één vleugel
	Openingswijze	<ul style="list-style-type: none"> - Draaiend - Kippend - Kippend-draaiend
4.2	Weerstand tegen windbelasting	C4
4.3	Weerstand tegen sneeuwbelasting	Niet bepaald, zie paragraaf 8.7.1
4.4.1	Brandreactie	Niet bepaald, zie paragraaf 8.7.2
4.4.2	Gedrag bij blootstelling aan externe brand	Niet bepaald, zie paragraaf 8.7.3
4.5	Waterdichtheid	E_{2000A}
4.6	Gevaarlijke substanties	Zie paragraaf 8.3
4.7	Schokweerstand (proef met zacht lichaam)	Klasse 5 ⁽²⁾
4.8	Weerstandvermogen van de veiligheidsvoorzieningen	Niet van toepassing
4.11	Akoestische prestaties	Zie paragraaf 8.4
4.12	Warmtedoorgangscoëfficiënt	Zie paragraaf 8.1.1
4.13	Stralingseigenschappen	Zie de declaratie van de fabrikant van de beglazing, zie paragraaf 8.7.5
4.14	Luchtdoorlatendheid	4
4.15	Duurzaamheid	Voldoet, zie paragraaf 8.7.6
4.16	Bedieningskrachten	1
4.17	Mechanische weerstand	4
4.18	Ventilatie	Zie de declaratie van de fabrikant van de verluchttingsvoorzieningen, zie paragraaf 8.7.7
4.19	Kogelweerstand	Niet bepaald, zie paragraaf 8.7.8
4.20	Explosie-weerstand	Niet bepaald, zie paragraaf 8.7.9
4.21	Weerstand tegen herhaald openen en sluiten	Niet bepaald, zie paragraaf 8.7.10 (hang- en sluitwerk: 15.000 cycli)
4.22	Gedrag tussen verschillende klimaten	Niet bepaald, zie paragraaf 8.7.11
4.23	Inbraakwerendheid	Niet bepaald

Fiche "Bijlage 5" – Hang- en sluitwerk "Sobinco meerpuntssluiting"

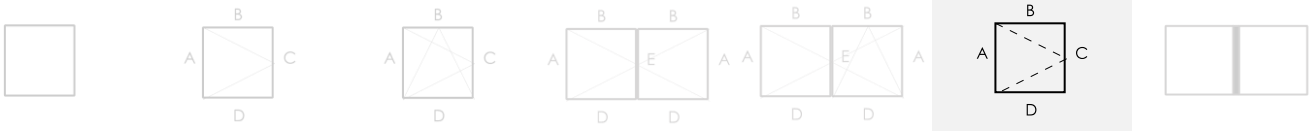

Eigenschappen van het hang- en sluitwerk cf. NBN EN 1935

Gebruiks-categorie	Duurzaamheid	Gewicht	Brandweerstand	Gebruiksveiligheid	Corrosieweerstand	Veiligheid	Scharnierklasse
4	7	6	0	1	4	0	13

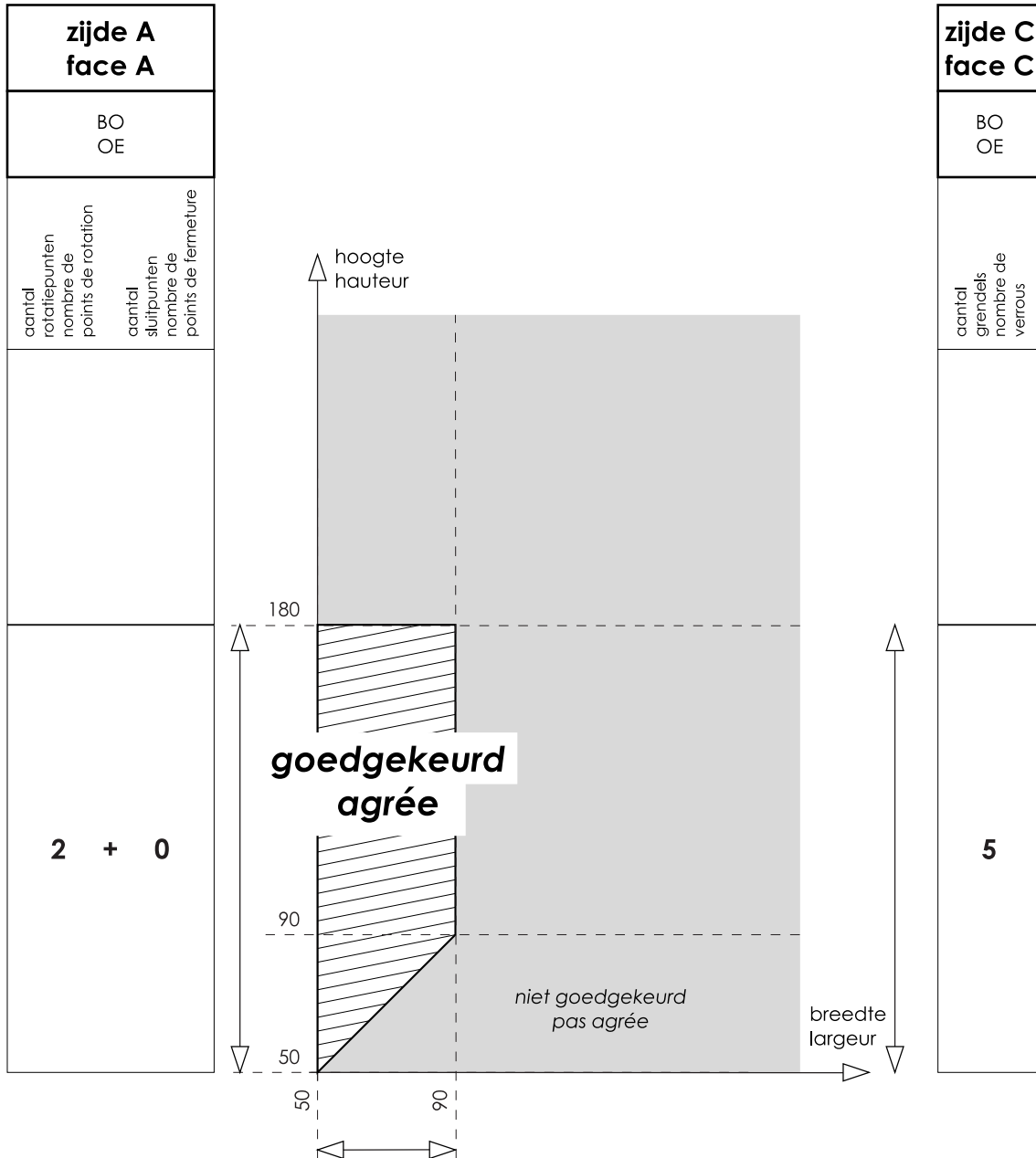

zijden B + D faces B + D	BO OE	0	aantal sluitpunten nombre de points de fermeture
-------------------------------------	----------	----------	---

De vleugel met het hoogste gewicht welke beproefd werd, woog 55 kg.

Fiche "Bijlage 5" (vervolg) – Hang- en sluitwerk "Sobinco meerpuntssluiting"



Eigenschappen van de vensters cf. NBN EN 14351-1

		Vensters met één vleugel
Openingswijze		– Buitendraaiend
4.2	Weerstand tegen windbelasting	C4
4.3	Weerstand tegen sneeuwbelasting	Niet bepaald, zie paragraaf 8.7.1
4.4.1	Brandreactie	Niet bepaald, zie paragraaf 8.7.2
4.4.2	Gedrag bij blootstelling aan externe brand	Niet bepaald, zie paragraaf 8.7.3
4.5	Waterdichtheid	9A
4.6	Gevaarlijke substanties	Zie paragraaf 8.3
4.7	Schokweerstand (proef met zacht lichaam)	Niet bepaald
4.8	Weerstandsvormogen van de veiligheidsvoorzieningen	Niet van toepassing
4.11	Akoestische prestaties	Zie paragraaf 8.4
4.12	Warmtedoorgangscoëfficiënt	Zie paragraaf 8.1.1
4.13	Stralingseigenschappen	Zie de declaratie van de fabrikant van de beglazing, zie paragraaf 8.7.5
4.14	Luchtdoorlatendheid	4
4.15	Duurzaamheid	Voldoet, zie paragraaf 8.7.6
4.16	Bedieningskrachten	2
4.17	Mechanische weerstand	4
4.18	Ventilatie	Zie de declaratie van de fabrikant van de verluchttingsvoorzieningen, zie paragraaf 8.7.7
4.19	Kogelweerstand	Niet bepaald, zie paragraaf 8.7.8
4.20	Explosie-weerstand	Niet bepaald, zie paragraaf 8.7.9
4.21	Weerstand tegen herhaald openen en sluiten	Niet bepaald, zie paragraaf 8.7.10 (hang- en sluitwerk: 200.000 cycli)
4.22	Gedrag tussen verschillende klimaten	Niet bepaald, zie paragraaf 8.7.11
4.23	Inbraakwerendheid	Niet bepaald

Fiche "Bijlage 6" – Hang- en sluitwerk "Roto NT Designo"

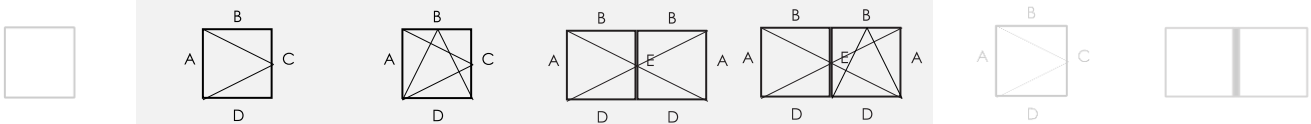

Eigenschappen van het hang- en sluitwerk cf. NBN EN 13126-8

Gebruiks-categorie	Duurzaamheid	Gewicht	Brand-weerstand	Gebruiks-veiligheid	Corrosie-weerstand	Veiligheid	Normdeel	Proefmaat
—	4	150	0	1	4	—	8	900 x 2300

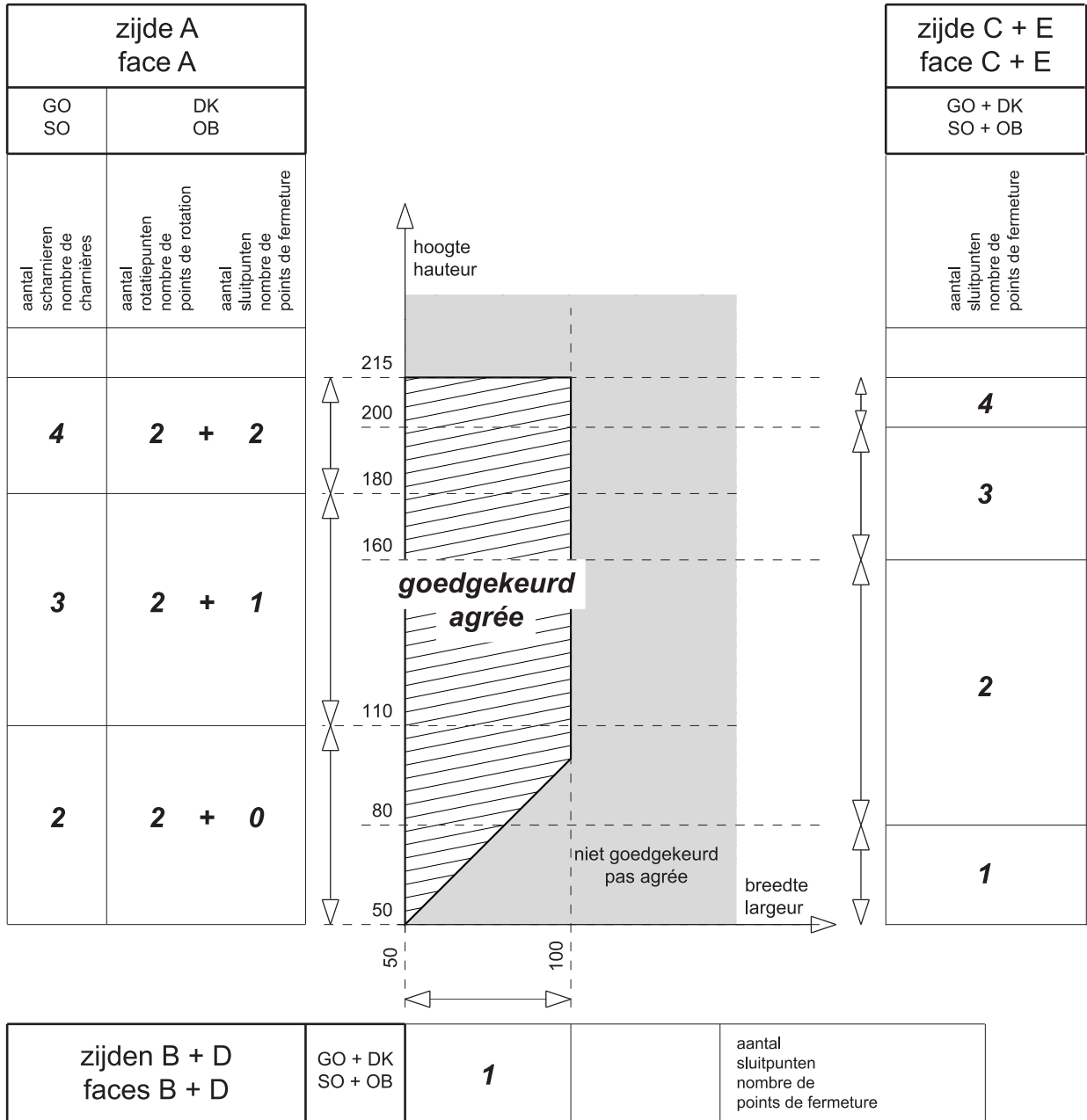

De vleugel met het hoogste gewicht welke beproefd werd, woog 52 kg.

Fiche "Bijlage 6" (vervolg) – Hang- en sluitwerk "Roto NT Designo"

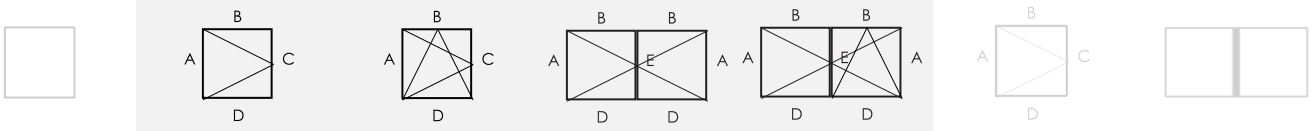

Eigenschappen van de vensters cf. NBN EN 14351-1

		Vensters met een of twee vleugels
Openingswijze		Primaire vleugel – draaiend, – kippend, of – kippend-draaiend Secundaire vleugel – draaiend
4.2	Weerstand tegen windbelasting	C3
4.3	Weerstand tegen sneeuwbelasting	Niet bepaald, zie paragraaf 8.7.1
4.4.1	Brandreactie	Niet bepaald, zie paragraaf 8.7.2
4.4.2	Gedrag bij blootstelling aan externe brand	Niet bepaald, zie paragraaf 8.7.3
4.5	Waterdichtheid	8A
4.6	Gevaarlijke substanties	Zie paragraaf 8.3
4.7	Schokweerstand (proef met zacht lichaam)	Klasse 3 (van binnen naar buiten) ⁽²⁾
4.8	Weerstandsvermogen van de veiligheidsvoorzieningen	Niet van toepassing
4.11	Akoestische prestaties	Zie paragraaf 8.4
4.12	Warmtedoorgangscoëfficiënt	Zie paragraaf 8.1.1
4.13	Stralingseigenschappen	Zie de declaratie van de fabrikant van de beglazing, zie paragraaf 8.7.5
4.14	Luchtdoorlatendheid	4
4.15	Duurzaamheid	Voldoet, zie paragraaf 8.7.6
4.16	Bedieningskrachten	1
4.17	Mechanische weerstand	4
4.18	Ventilatie	Zie de declaratie van de fabrikant van de verluchttingsvoorzieningen, zie paragraaf 8.7.7
4.19	Kogelweerstand	Niet bepaald, zie paragraaf 8.7.8
4.20	Explosie-weerstand	Niet bepaald, zie paragraaf 8.7.9
4.21	Weerstand tegen herhaald openen en sluiten	Niet bepaald, zie paragraaf 8.7.10 (hang- en sluitwerk: 15.000 cycli)
4.22	Gedrag tussen verschillende klimaten	Niet bepaald, zie paragraaf 8.7.11
4.23	Inbraakwerendheid	Niet bepaald
⁽²⁾ : indien deze eigenschap gevraagd is, moet het glas minstens van de samenstellingen 44.2 zijn langs de kant waar de schok wordt verwacht		

Fiche "Bijlage 7" – Samengestelde vensters

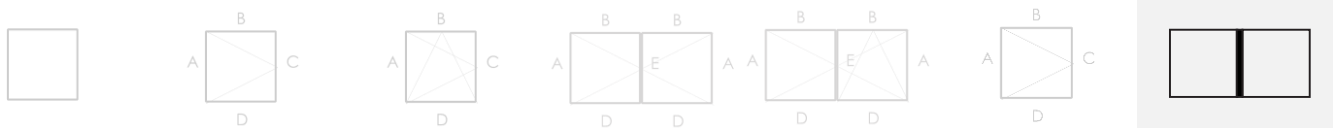

Eigenschappen van de vensters cf. NBN EN 14351-1

		Samengestelde vensters
Openingswijze		Zie opengaande delen
Hang- en sluitwerk		Zie opengaande delen
4.2	Weerstand tegen windbelasting	Meest negatieve van de componenten (C3 of C4)
4.3	Weerstand tegen sneeuwbelasting	Niet bepaald, zie paragraaf 8.7.1
4.4.1	Brandreactie	Niet bepaald, zie paragraaf 8.7.2
4.4.2	Gedrag bij blootstelling aan externe brand	Niet bepaald, zie paragraaf 8.7.3
4.5	Waterdichtheid	Meest negatieve van de componenten (8A tot E ₂₀₀₀)
4.6	Gevaarlijke substanties	Zie paragraaf 8.3
4.7	Schokweerstand	Meest negatieve van de componenten (niet bepaald tot klasse 5)
4.8	Weerstandsvormogen van de veiligheidsvoorzieningen	Niet van toepassing
4.11	Akoestische prestaties	Zie paragraaf 8.4
4.12	Warmte-doorgangscoefficient	Zie paragraaf 8.1.1
4.13	Stralingseigenschappen	Zie de declaratie van de fabrikant van de beglazing, zie paragraaf 8.7.5
4.14	Luchtdoorlatendheid	4
4.15	Duurzaamheid	Voldoet, zie paragraaf 8.7.6
4.16	Bedieningskrachten	Meest negatieve van de componenten (1 tot 2)
4.17	Mechanische weerstand	4
4.18	Ventilatie	Zie de declaratie van de fabrikant van de ventilatievoorzieningen, zie paragraaf 8.7.7
4.19	Kogelweerstand	Niet bepaald, zie paragraaf 8.7.8
4.20	Explosieweerstand	Niet bepaald, zie paragraaf 8.7.9
4.21	Weerstand tegen herhaald openen en sluiten	Meest negatieve van de componenten (hang- en sluitwerk: 15.000 tot 200.000 cycli)
4.22	Gedrag tussen verschillende klimaten	Niet bepaald, zie paragraaf 8.7.11
4.23	Inbraakwerendheid	Meest negatieve van de componenten (niet bepaald tot klasse RC2)

De BUTgb vzw is een goedkeuringsinstituut dat lid is van de Europese Unie voor de technische goedkeuring in de bouw (UEAtc, zie www.ueatc.eu) en dat aangeduid werd door de FOD Economie in het kader van Verordening (EU) N° 305/2011 en lid is van de Europese Organisatie voor Technische Beoordeling (EOTA, zie www.eota.eu). De door de BUTgb vzw aangeduide certificatie-operatoren werken volgens een door BELAC (www.belac.be) accreditiebaar systeem.

Deze technische goedkeuring werd gepubliceerd door de BUTgb, onder verantwoordelijkheid van de goedkeuringsoperator BCCA, en op basis van het gunstig advies van het Uitvoerend Bureau "Gevels", verleend op 14 maart 2014.

Daarnaast bevestigde de certificatieoperator BCCA, dat de productie aan de certificatievoorwaarden voldoet en dat met de houder een certificatieovereenkomst ondertekend werd.

Datum van deze uitgave: 31 juli 2015

Voor de BUTgb, als geldigverklaring van het goedkeuringsproces



Peter Wouters, directeur

Voor de goedkeurings- en certificatieoperator



Benny De Blaere, directeur

Deze technische goedkeuring blijft geldig, gesteld dat het product, de vervaardiging ervan en alle daarmee verband houdende relevante processen:

- onderhouden worden, zodat minstens de prestatieniveaus bereikt worden zoals bepaald in deze beperkte goedkeuringstekst
- doorlopend aan de controle door de certificatieoperator onderworpen worden en deze bevestigt dat de certificatie geldig blijft

Wanneer niet langer wordt voldaan aan deze voorwaarden, zal de beperkte technische goedkeuring worden geschorst of ingetrokken en de goedkeuringstekst van de BUTgb website worden verwijderd.



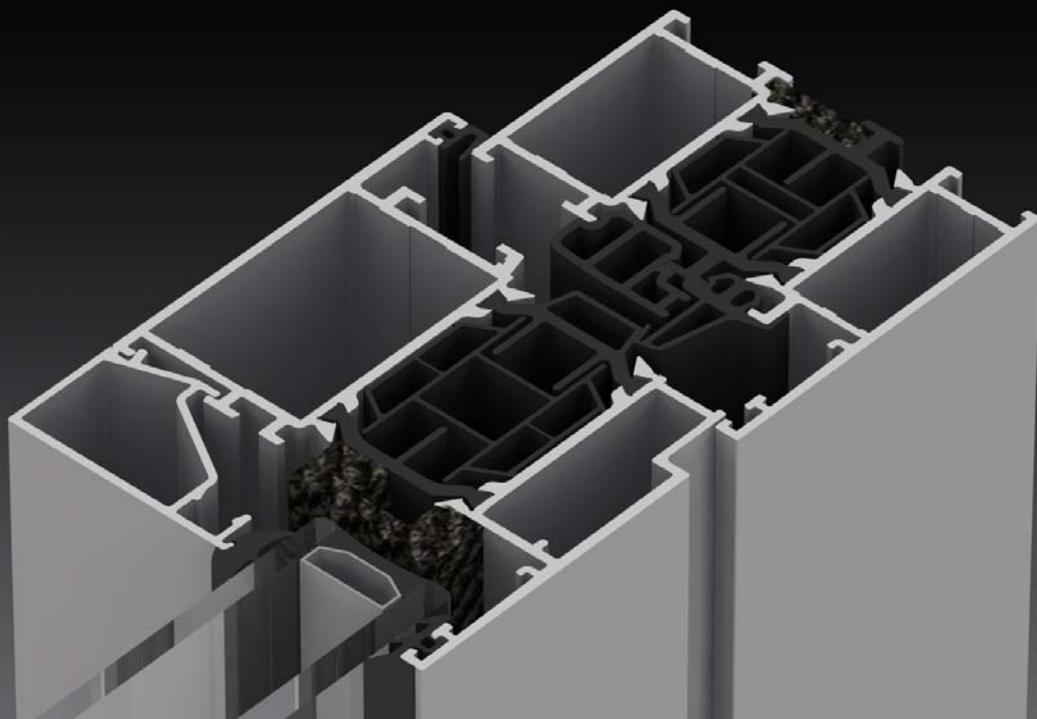

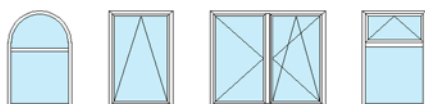

De geldigheid versie van deze goedkeuringstekst kan nagegaan worden door de BUTgb website (www.butgb.be) te consulteren of door rechtstreeks contact op te nemen met het Butgb-secretariaat.

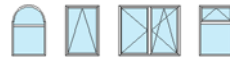

Triton 03







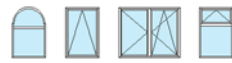



				
 <p>A-03-100</p> <p>Glassteun Support cale de vitrage Glazing support</p>	<p>-ST 100 -ST 800</p> 	●		<p>P-03-A1.. P-03-A2.. P-03-A3..</p>
 <p>A-03-200</p> <p>Stolpeindstuk ramen Embout pour montant central fenêtre Double-casement component windows</p>	<p>-ST 10 -ST 50 -ST 150</p> 	● ○		<p>P-03-A400</p>

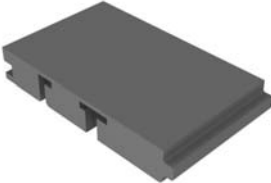

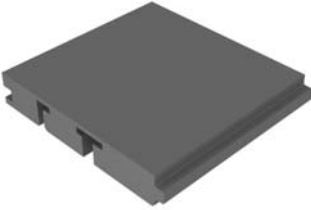
	<p>A-03-230B</p> <p>Stolpeindstuk voor raam Embout maclair pour fenêtre Sealing double casement prof for window</p>	<p>-ST 5</p>		<p>P-03-A430B</p>
--	--	---------------------	--	-------------------

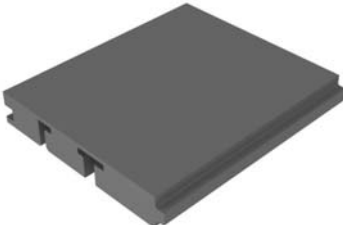

	<p>A-03-300</p> <p>Afdichting voor T-profiel Pièce d'étanchéité pour traverse Sealing for transom-mullion</p> <p>29 mm</p>	<p>-ST 50</p> 		<p>P-03-A1.. P-03-A3..</p>
	<p>A-03-301</p> <p>Afdichting voor T-profiel Pièce d'étanchéité pour traverse Sealing for transom-mullion</p> <p>45 mm</p>	<p>-ST 50</p> 		<p>P-03-A1.. P-03-A3..</p>
	<p>A-03-302</p> <p>Afdichting voor T-profiel Pièce d'étanchéité pour traverse Sealing for transom-mullion</p> <p>55 mm</p>	<p>-ST 50</p> 		<p>P-03-A1.. P-03-A3..</p>

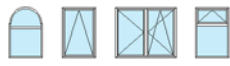

Triton 03

toebehoren - accessories - accessoires

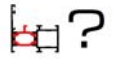

A-01-305







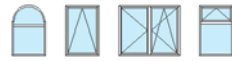

Eindstuk versterkte T-profiel
Embout pour traverse renforcé
Component for reinforced transom

-ST 10
-ST 24



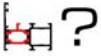









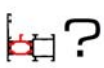









P-03-A305



			
 <p>A-02-306</p> <p>Eindstuk versterkte T-profiel Embout pour traverse renforcé Component for reinforced transom</p>	<p>-ST 10 -ST 24</p> 		<p>P-03-A306</p>











				
 <p>A-00-100</p> <p>Waterkapje Busette Drain hole cover</p>	<p>-ST 100 -ST 2000</p> 	 	<p>P-03-A1.. P-03-A3..</p>  <p>A-KM-5402</p>	
 <p>A-00-102</p> <p>Monodrain Blinde ontwatering Monodrain drainage invisible Monodrain Blind drainage</p>	<p>-ST 10</p> 		<p>P-03-A1.. P-03-A2..</p>	
 <p>A-00-103</p> <p>Speciale Inbusschroef M6 x 18 Vis speciale M6 x 18 Speciale screw M6 x 18</p>	<p>-ST 100</p> 		<p>A-TV-...</p>	
 <p>A-00-105</p> <p>Verstekhoekje Equerre d'alignement Framing square</p>	<p>-ST 200 -ST 3000</p> 		<p>P-03-A1.. P-03-A2..</p>	
 <p>A-00-106</p> <p>Koppelstukje T-profiel Pièce de montage pour traverse Component for transom assembly</p>	<p>-ST 100 -ST 2000</p> 		<p>P-03-A3..</p>	



	<p>A-00-110</p> <p>Schroefblokje Clavette Cleat tensioning block</p>	-ST 40 		A-SH-...
	<p>A-00-111</p> <p>Schroef t-verbinders Vis assemblage-t Screw transom bracket</p>	-ST 40 		A-TV-... A-VT-... A-VH-...
	<p>A-00-112</p> <p>Schroef T-profiel Vis traverse Screw transom-mullion</p>	-ST 100 		P-03-A310 P-03-A311 P-03-A312
	<p>A-00-115</p> <p>Muuranker Fixation murale Wall anchor</p>	-ST 100 -ST 1000 		P-03-A1..
	<p>A-00-116</p> <p>Plaathouder Porteur de plaque Plate-holder</p> <p>OUT</p>	-ST 50 		P-03-A1..



				
 <p>A-00-117</p> <p>Plaathouder Porteur de plaque Plate-holder</p> <p>IN</p>	<p>-ST 50</p> 		<p>P-03-A1..</p>	

 <p>A-00-135</p> <p>Hoek middendichting Pièce d'angle moulé joint central Hook central gasket</p>	<p>-ST 20 -ST 200</p> 		<p>P-03-A1.. P-03-A3..</p>
---	--	---	--------------------------------





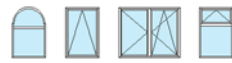

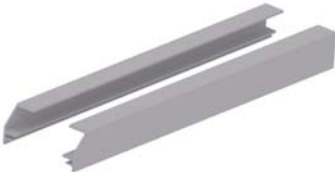
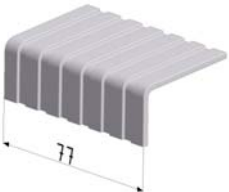





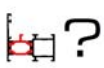
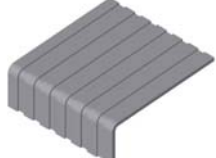



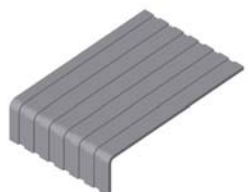



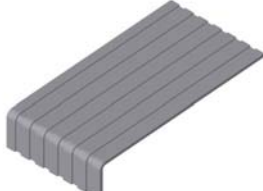



	<p>A-00-E140</p> <p>Dorpelafsluitstukjes 140mm Pieces lateral seuil 140mm Sealing for windowsill 140mm</p>	<p>-ST 1</p>	 	<p>P-00-72.</p>
	<p>A-00-E230</p> <p>Dorpelafsluitstukjes 230mm Pieces lateral seuil 230mm Sealing for windowsill 230mm</p>	<p>-ST 1</p>	 	<p>P-00-72.</p>
	<p>A-00-EB143</p> <p>Dorpelafsluitstukjes 143mm Pieces lateral seuil 143mm Sealing for windowsill 143mm</p>	<p>-ST 1</p>	 	<p>P-00-72.</p>
	<p>A-00-EB233</p> <p>Dorpelafsluitstukjes 233mm Pieces lateral seuil 233mm Sealing for windowsill 233mm</p>	<p>-ST 1</p>	 	<p>P-00-72.</p>







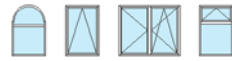

 <p>A-00-EC140 Dorpelafsluitstukjes 140mm Pieces lateral seuil 140mm Sealing for windowsill 140mm</p>	-ST 1 		P-00-72.
 <p>A-00-EC230 Dorpelafsluitstukjes 230mm Pieces lateral seuil 230mm Sealing for windowsill 230mm</p>	-ST 1 		P-00-72.
 <p>A-00-ED143 Dorpelafsluitstukjes 143mm Pieces lateral seuil 143mm Sealing for windowsill 143mm</p>	-ST 1 		P-00-72.
 <p>A-00-ED233 Dorpelafsluitstukjes 233mm Pieces lateral seuil 233mm Sealing for windowsill 233mm</p>	-ST 1 		P-00-72.
 <p>A-00-K050 Koppelstuk raamdorpel P-00-720 Pièce raccord seuil P-00-720 Connector for windowsill P-00-720</p>	-ST 1 		P-00-720

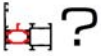
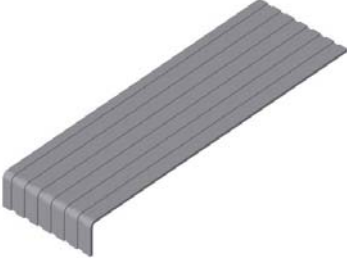

				
 <p>A-00-K080</p> <p>Koppelstuk raamdorpel P-00-721 Pièce raccord seuil P-00-721 Connector for windowsill P-00-721</p>	-ST 1 	 	P-00-721	
 <p>A-00-K110</p> <p>Koppelstuk raamdorpel P-00-722 Pièce raccord seuil P-00-722 Connector for windowsill P-00-722</p>	-ST 1 	 	P-00-722	
 <p>A-00-K140</p> <p>Koppelstuk raamdorpel P-00-723 Pièce raccord seuil P-00-723 Connector for windowsill P-00-723</p>	-ST 1 	 	P-00-723	
 <p>A-00-K170</p> <p>Koppelstuk raamdorpel P-00-724 Pièce raccord seuil P-00-724 Connector for windowsill P-00-724</p>	-ST 1 	 	P-00-724	
 <p>A-00-K200</p> <p>Koppelstuk raamdorpel P-00-725 Pièce raccord seuil P-00-725 Connector for windowsill P-00-725</p>	-ST 1 	 	P-00-725	















			
 <p>A-00-K230</p> <p>Koppelstuk raamdorpel P-00-726 Pièce raccord seuil P-00-726 Connector for windowsill P-00-726</p>	<p>-ST 1</p> 	 	<p>P-00-726</p>











	<p>A-GS-100</p> <p>Beglazingsrubber Joint de vitrage Sealing gasket</p>	<p>-LM 100</p>	●	<p>P-03-A1.. P-03-A2.. P-03-A3..</p>
	<p>A-GS-110</p> <p>Beglazingsrubber Joint de vitrage Sealing gasket</p>	<p>-LM 100</p>	●	<p>P-03-A1.. P-03-A2.. P-03-A3..</p>
	<p>A-GS-115</p> <p>Aanslagdichting Joint de frappe Flipper gasket</p>	<p>-LM 100</p>	●	<p>P-03-A1.. P-03-A3.. P-03-A4..</p>
	<p>A-GS-131</p> <p>Aanslagdichting ramen Joint de frappe fenêtres Flipper gasket windows</p>	<p>-LM 100</p>	●	<p>P-03-A2..</p>
	<p>A-GS-133</p> <p>Aanslagdichting deuren Joint de frappe portes Flipper gasket doors</p>	<p>-LM 100</p>	●	<p>P-03-A2..</p>



	<p>A-GS-135</p> <p>Middendichting Joint central Central gasket</p>	<p>-LM 50</p> 		<p>P-03-A1.. P-03-A3..</p>
	<p>A-GS-136</p> <p>Middendichting Joint central Central gasket</p>	<p>-LM 40</p> 		<p>P-03-A1.. P-03-A3..</p>
	<p>A-GS-303</p> <p>Beglazingsrubber 3mm Joint de vitrage 3mm Sealing gasket 3mm</p>	<p>-LM 100</p> 		<p>P-03-A1.. P-03-A2.. P-03-A3..</p>
	<p>A-GS-304</p> <p>Beglazingsrubber 4mm Joint de vitrage 4mm Sealing gasket 4mm</p>	<p>-LM 100</p> 		<p>P-03-A1.. P-03-A2.. P-03-A3..</p>





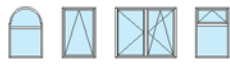





				
 <p>A-GS-305</p> <p>Beglazingsrubber 5mm Joint de vitrage 5mm Sealing gasket 5mm</p>	<p>-LM 100</p> 	●		<p>P-03-A1.. P-03-A2.. P-03-A3..</p>
 <p>A-GS-306</p> <p>Beglazingsrubber 6mm Joint de vitrage 6mm Sealing gasket 6mm</p>	<p>-LM 100</p> 	●		<p>P-03-A1.. P-03-A2.. P-03-A3..</p>
 <p>A-GS-308</p> <p>Beglazingsrubber 8mm Joint de vitrage 8mm Sealing gasket 8mm</p>	<p>-LM 100</p> 	●		<p>P-03-A1.. P-03-A2.. P-03-A3..</p>



toebehoren - accessories - accessoires



	<p>A-GS-706</p> <p>Basisrubber Joint de base Base gasket</p>	<p>-LM 25</p> 		<p>P-03-A1..</p>
	<p>A-GS-900</p> <p>Isolatieband bande d'isolation Insulation tape</p>	<p>-LM 100</p> 		<p>P-03-A1.. P-03-A2.. P-03-A3..</p>
	<p>A-GS-901</p> <p>Isolatieband bande d'isolation Insulation tape</p>	<p>-LM 80</p> 		<p>P-03-A1..</p>

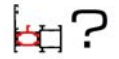
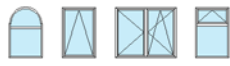

	<p>A-GH-1115</p> <p>Stifthoek Clame à goupille Pin corner cleat</p>	<p>-ST 4 -ST 40</p>		<p>P-03-A116 P-03-A300</p>
	<p>A-HM-105</p> <p>Verstekhoek Equerre d'alignement Framing square</p>	<p>-ST 20 -ST 250</p>		<p>P-03-A1.. P-03-A2.. P-03-A3..</p>
	<p>A-PH-1110</p> <p>Pershoek Equerre à sertir Clamping corner</p>	<p>-ST 20 -ST 100 -ST 500</p>		<p>P-03-A200 P-03-A210</p>



				
	<p>A-PH-1115</p> <p>Pershoek Equerre à sertir Clamping corner</p>	<p>-ST 20 -ST 100</p> 		P-03-A300
	<p>A-PH-1415</p> <p>Pershoek Equerre à sertir Clamping corner</p>	<p>-ST 20 -ST 100 -ST 300</p> 		<p>P-03-A100 P-03-A107 P-03-A111 P-03-A117 P-03-A119 P-03-A404 P-03-403</p>
	<p>A-PH-1430</p> <p>Pershoek Equerre à sertir Clamping corner</p>	<p>-ST 20 -ST 100</p> 		<p>P-03-A230B P-03-A240B</p>
	<p>A-PH-1464</p> <p>Pershoek Equerre à sertir Clamping corner</p>	<p>-ST 20 -ST 100</p> 		P-03-A115
	<p>A-PH-1607</p> <p>Pershoek Equerre à sertir Clamping corner</p>	<p>-ST 20 -ST 100</p> 		<p>P-03-A405 P-03-B405</p>

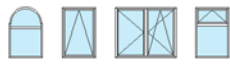

				
	<p>A-PH-1610</p> <p>Pershoek Equerre à sertir Clamping corner</p>	<p>-ST 20 -ST 100</p> 		<p>P-03-A230B P-03-A240B</p>
	<p>A-PH-1616</p> <p>Pershoek Equerre à sertir Clamping corner</p>	<p>-ST 20 -ST 100</p> 		<p>P-03-A404</p>
	<p>A-PH-1621</p> <p>Pershoek Equerre à sertir Clamping corner</p>	<p>-ST 20 -ST 200</p> 		<p>P-03-A100 P-03-A107 P-03-A111 P-03-A115 P-03-A117 P-03-A119 P-03-A123 P-03-A300 P-03-A309 P-03-403</p>
	<p>A-PH-1630</p> <p>Pershoek Equerre à sertir Clamping corner</p>	<p>-ST 20 -ST 200</p> 		<p>P-03-A200 P-03-A210</p>
	<p>A-PH-1665</p> <p>Pershoek Equerre à sertir Clamping corner</p>	<p>-ST 20 -ST 100</p> 		<p>P-03-A109 P-03-A110</p>



				
	<p>A-PH-2036</p> <p>Pershoek Équerre à sertir Clamping corner</p>	<p>-ST 20 -ST 100</p> 		P-03-A108
	<p>A-PH-2314</p> <p>Pershoek Équerre à sertir Clamping corner</p>	<p>-ST 20 -ST 100</p> 		P-03-A104
	<p>A-PH-2520</p> <p>Pershoek Équerre à sertir Clamping corner</p>	<p>-ST 20 -ST 100</p> 		P-03-A104
	<p>A-PH-2710</p> <p>Pershoek Équerre à sertir Clamping corner</p>	<p>-ST 20 -ST 100</p> 		P-03-A201 P-03-A211
	<p>A-PH-2715</p> <p>Pershoek Équerre à sertir Clamping corner</p>	<p>-ST 20 -ST 100</p> 		P-03-A301 P-03-A123



				
 <p>A-PH-2730</p> <p>Pershoek Équerre à sertir Clamping corner</p>	<p>-ST 20 -ST 100</p> 			<p>P-03-A231B P-03-A241B</p>
 <p>A-PH-3010</p> <p>Pershoek Équerre à sertir Clamping corner</p>	<p>-ST 20 -ST 100</p> 			<p>P-03-A231B P-03-A241B</p>
 <p>A-PH-3015</p> <p>Pershoek Equerre à sertir Clamping corner</p>	<p>-ST 20 -ST 100</p> 			<p>P-03-A101 P-03-A113 P-03-A118</p>
 <p>A-PH-3025</p> <p>Pershoek Equerre à sertir Clamping corner</p>	<p>-ST 4</p> 			<p>P-03-A405 P-03-B405</p>
 <p>A-PH-3221</p> <p>Pershoek Equerre à sertir Clamping corner</p>	<p>-ST 20 -ST 100</p> 			<p>P-03-A101 P-03-A108 P-03-A109 P-03-A110 P-03-A113 P-03-A118 P-03-A301</p>





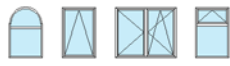

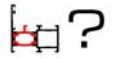

				
 <p>A-PH-3230</p> <p>Pershoek Equerre à sertir Clamping corner</p>	<p>-ST 20 -ST 100</p> 			<p>P-03-A201 P-03-A211</p>
 <p>A-PH-3709</p> <p>Pershoek Équerre à sertir Clamping corner</p>	<p>-ST 20 -ST 100</p> 			<p>P-03-A309</p>
 <p>A-PH-3710</p> <p>Pershoek Equerre à sertir Clamping corner</p>	<p>-ST 20 -ST 100</p> 			<p>P-03-A202</p>
 <p>A-PH-3715</p> <p>Pershoek Equerre à sertir Clamping corner</p>	<p>-ST 20 -ST 100</p> 			<p>P-03-A302</p>

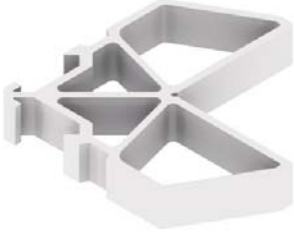

toebehoren - accessories - accessoires



	<p>A-PH-4015</p> <p>Pershoek Equerre à sertir Clamping corner</p>	<p>-ST 20 -ST 100</p> 		<p>P-03-A102</p>
---	--	--	---	------------------

	<p>A-PH-4221</p> <p>Pershoek Equerre à sertir Clamping corner</p>	<p>-ST 20 -ST 100</p> 		<p>P-03-A102 P-03-A302</p>
---	--	--	---	--------------------------------

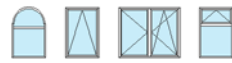

	<p>A-PH-4230</p>	<p>-ST 20 -ST 100</p>		<p>P-03-A202 P-03-A203 P-03-A212 P-03-A213</p>
	<p>A-PH-4709</p>	<p>-ST 20 -ST 100</p>		<p>P-03-A319</p>

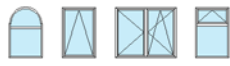

	<p>A-SH-1110</p> <p>Schroefhoek Equerre à visser Square coupling joint</p>	<p>-ST 4 -ST 40</p>		<p>P-03-A200 P-03-A210</p> <p>A-KM-5407</p>
	<p>A-SH-1415</p> <p>Schroefhoek Equerre à visser Square coupling joint</p>	<p>-ST 4 -ST 40</p>		<p>P-03-A100 P-03-A111 P-03-A117 P-03-A404 P-03-403</p> <p>A-KM-5407 A-KM-5417</p>
	<p>A-SH-1465</p> <p>Schroefhoek Equerre à visser Square coupling joint</p>	<p>-ST 4 -ST 40</p>		<p>P-03-A115</p> <p>A-KM-5407</p>
	<p>A-SH-1620</p> <p>Schroefhoek Equerre à visser Square coupling joint</p>	<p>-ST 4 -ST 40</p>		<p>P-03-A117</p> <p>A-KM-5417</p>



<p>A-SH-1621</p> <p>Schroefhoek Equerre à visser Square coupling joint</p>	<p>-ST 4 -ST 40</p>		<p>P-03-A100 P-03-A107 P-03-A111 P-03-A115 P-03-A116 P-03-A123 P-03-A300 P-03-A309 P-03-403</p> <p>A-KM-5407</p>	
<p>A-SH-1630</p> <p>Schroefhoek Equerre à visser Square coupling joint</p>	<p>-ST 4 -ST 40</p>		<p>P-03-A200 P-03-A210</p> <p>A-KM-5407</p>	
<p>A-SH-1662</p> <p>Schroefhoek Equerre à visser Square coupling joint</p>	<p>-ST 4 -ST 40</p>		<p>P-03-A110</p> <p>A-KM-5407</p>	
<p>A-SH-1665</p> <p>Schroefhoek Equerre à visser Square coupling joint</p>	<p>-ST 4 -ST 40</p>		<p>P-03-A109</p> <p>A-KM-5407</p>	
<p>A-SH-2036</p> <p>Schroefhoek Equerre à visser Square coupling joint</p>	<p>-ST 4 -ST 40</p>		<p>P-03-A108</p> <p>A-KM-5407</p>	



				
 <p>A-SH-2314</p> <p>Schroefhoek Équerre à visser Square coupling joint</p>	<p>-ST 4 -ST 40</p> 			<p>P-03-A104</p>  <p>A-KM-5407</p>
 <p>A-SH-2520</p> <p>Schroefhoek Équerre à visser Square coupling joint</p>	<p>-ST 4 -ST 40</p> 			<p>P-03-A104</p>  <p>A-KM-5407</p>
 <p>A-SH-2710</p> <p>Schroefhoek Equerre à visser Square coupling joint</p>	<p>-ST 4 -ST 40</p> 			<p>P-03-A201 P-03-A211</p>  <p>A-KM-5407</p>
 <p>A-SH-2715</p> <p>Schroefhoek Equerre à visser Square coupling joint</p>	<p>-ST 4 -ST 40</p> 			<p>P-03-A123</p>  <p>A-KM-5407</p>
 <p>A-SH-3015</p> <p>Schroefhoek Equerre à visser Square coupling joint</p>	<p>-ST 4 -ST 40</p> 			<p>P-03-A101 P-03-A113 P-03-A118</p>  <p>A-KM-5407 A-KM-5417</p>











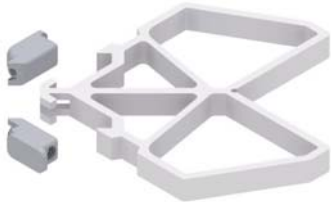

 <p>A-SH-3025</p> <p>Schroefhoek Equerre à visser Square coupling joint</p>	<p>-ST 4</p> 		<p>P-03-A405 P-03-B405</p>  <p>A-KM-5407</p>	
 <p>A-SH-3220</p> <p>Schroefhoek Equerre à visser Square coupling joint</p>	<p>-ST 4</p> 		<p>P-03-A118</p>  <p>A-KM-5417</p>	
 <p>A-SH-3221</p> <p>Schroefhoek Equerre à visser Square coupling joint</p>	<p>-ST 4 -ST 40</p> 		<p>P-03-A101 P-03-A108 P-03-A109 P-03-A110 P-03-A113 P-03-A301</p>  <p>A-KM-5407</p>	
 <p>A-SH-3230</p> <p>Schroefhoek Equerre à visser Square coupling joint</p>	<p>-ST 4 -ST 40</p> 		<p>P-03-A201 P-03-A211</p>  <p>A-KM-5407</p>	
 <p>A-SH-3709</p> <p>Schroefhoek Équerre à visser Square coupling joint</p>	<p>-ST 4 -ST 40</p> 		<p>P-03-A309</p>  <p>A-KM-5412</p>	



				
 <p>A-SH-3710 Schroefhoek Equerre à visser Square coupling joint</p>	<p>-ST 4 -ST 40</p> 			<p>P-03-A202 P-03-A212</p>  <p>A-KM-5407</p>
 <p>A-SH-4015 Schroefhoek Equerre à visser Square coupling joint</p>	<p>-ST 4 -ST 40</p> 			<p>P-03-A102</p>  <p>A-KM-5407</p>
 <p>A-SH-4221 Schroefhoek Equerre à visser Square coupling joint</p>	<p>-ST 4 -ST 40</p> 			<p>P-03-A102 P-03-A302</p>  <p>A-KM-5407</p>
 <p>A-SH-4230 Schroefhoek Equerre à visser Square coupling joint</p>	<p>-ST 4 -ST 40</p> 			<p>P-03-A202 P-03-A212</p>  <p>A-KM-5407</p> <p>P-03-A203 P-03-A213</p>  <p>A-KM-5403</p>



			
 <p>A-SH-4709</p> <p>Schroefhoek Equerre à visser Square coupling joint</p>	<p>-ST 4 -ST 40</p> 		<p>P-03-A319</p>  <p>A-KM-5412</p>

 <p>A-TV-001</p> <p>T-verbinding Attacher traverse Connecting component for transom</p>	<p>-ST 10 -ST 1000</p> 		<p>P-03-A100 P-03-A111 P-03-A300 P-03-A303 P-03-A304 P-03-A305 P-03-A315 P-03-A320</p>  <p>A-KM-5407</p>
---	---	---	---









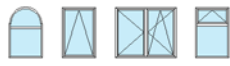



				
 <p>A-TV-002</p> <p>T-verbinding Attacher traverse Connecting component for transom</p>	-ST 10 		P-03-A101 P-03-A113 P-03-A301 P-03-A306  A-KM-5407	
 <p>A-TV-003</p> <p>T-verbinding Attacher traverse Connecting component for transom</p>	-ST 10 		P-03-A102 P-03-A302 P-03-A332  A-KM-5407	
 <p>A-TV-005</p> <p>T-verbinding Attacher traverse Connecting component for transom</p>	-ST 10 		P-03-A300 P-03-A305 P-03-A315 P-03-A320  A-KM-5407	
 <p>A-TV-014</p> <p>T-verbinding Attacher traverse Connecting component for transom</p>	-ST 10 		P-03-A104  A-KM-5407	
 <p>A-TV-057</p> <p>T-verbinding Attacher traverse Connecting component for transom</p>	-ST 10 		P-03-A300 P-03-A305 P-03-A315 P-03-A320  A-KM-5407	



 <p>A-TV-064</p> <p>T-verbinding Attacher traverse Connecting component for transom</p>	<p>-ST 10</p> 		<p>P-03-A300 P-03-A305 P-03-A315 P-03-A320</p>  A-KM-5407	
 <p>A-TV-065</p> <p>T-verbinding Attacher traverse Connecting component for transom</p>	<p>-ST 10</p> 		<p>P-03-A301 P-03-A303 P-03-A304 P-03-A306</p>  A-KM-5407	
 <p>A-TV-066</p> <p>T-verbinding Attacher traverse Connecting component for transom</p>	<p>-ST 10</p> 		<p>P-03-A302 P-03-A332</p>  A-KM-5407	
 <p>A-TV-067</p> <p>T-verbinding Attache traverse Connecting component for transom</p>	<p>-ST 10</p> 		<p>P-03-A100 P-03-A111</p>  A-KM-5407	
 <p>A-TV-068</p> <p>T-verbinding Attache traverse Connecting component for transom</p>	<p>-ST 10</p> 		<p>P-03-A101 P-03-A113</p>  A-KM-5407	



				
 <p>A-TV-069 T-verbinding Attache traverse Connecting component for transom</p>	<p>-ST 10 </p>		<p>P-03-A102  A-KM-5407</p>	
 <p>A-TV-075 T-verbinding Attache traverse Connecting component for transom</p>	<p>-ST 10 </p>		<p>P-03-A104  A-KM-5407</p>	



P-03-A100

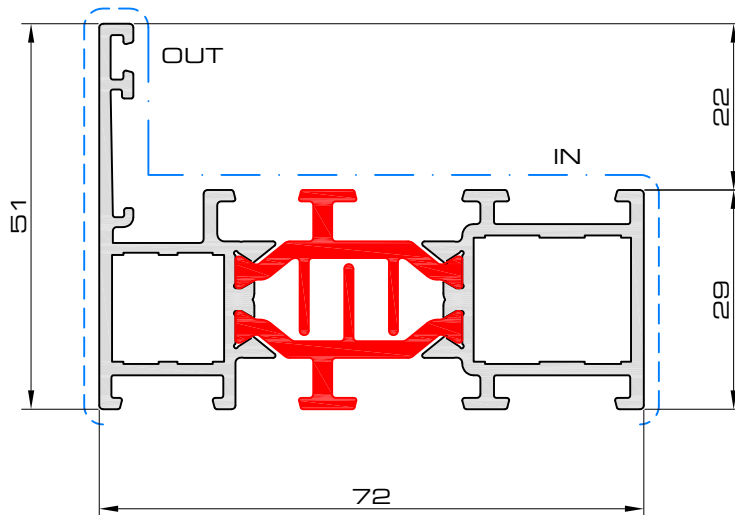

	OUT	IN
	A-PH-1415	A-PH-1621
	A-SH-1415	A-SH-1621
	A-TV-067	A-TV-001
	A-VH-1415	A-VH-1621
	$I_x = 30.29\text{cm}^4$ $I_y = 6.23\text{cm}^4$ $W_x = 7.64\text{cm}^3$ $W_y = 1.85\text{cm}^3$	

P-03-A101

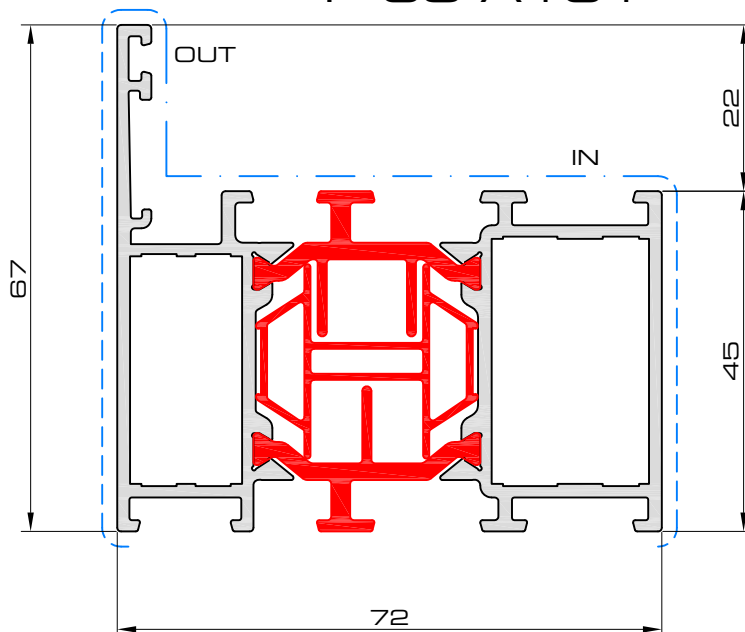

	OUT	IN
	A-PH-3015	A-PH-3221
	A-SH-3015	A-SH-3221
	A-TV-068	A-TV-002
	A-VH-3015	A-VH-3221
	$I_x = 38.6\text{cm}^4$ $I_y = 16.11\text{cm}^4$ $W_x = 9.84\text{cm}^3$ $W_y = 3.89\text{cm}^3$	

prof1

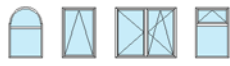

profielen - profils - profiles

P-03-A102

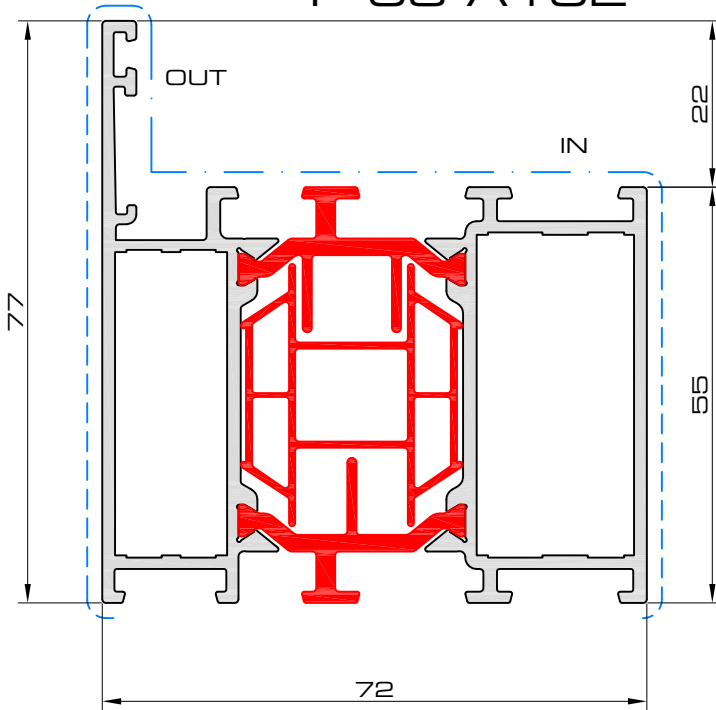

	OUT	IN
	A-PH-4015	A-PH-4221
	A-SH-4015	A-SH-4221
	A-TV-069	A-TV-003
	A-VH-4015	A-VH-4221
	$I_x = 43.71\text{cm}^4$ $I_y = 25.81\text{cm}^4$ $W_x = 11.2\text{cm}^3$ $W_y = 5.57\text{cm}^3$	

P-03-A104

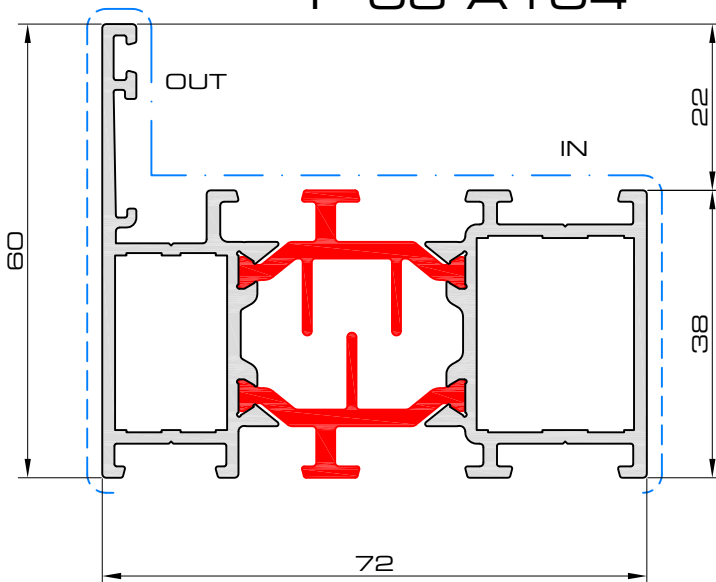

	OUT	IN
	A-PH-2314	A-PH-2520
	A-SH-2314	A-SH-2520
	A-TV-075	A-TV-014
	$I_x = 34.99\text{cm}^4$ $I_y = 10.99\text{cm}^4$ $W_x = 8.89\text{cm}^3$ $W_y = 2.89\text{cm}^3$	

prof2

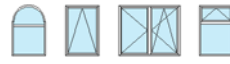

P-03-A103

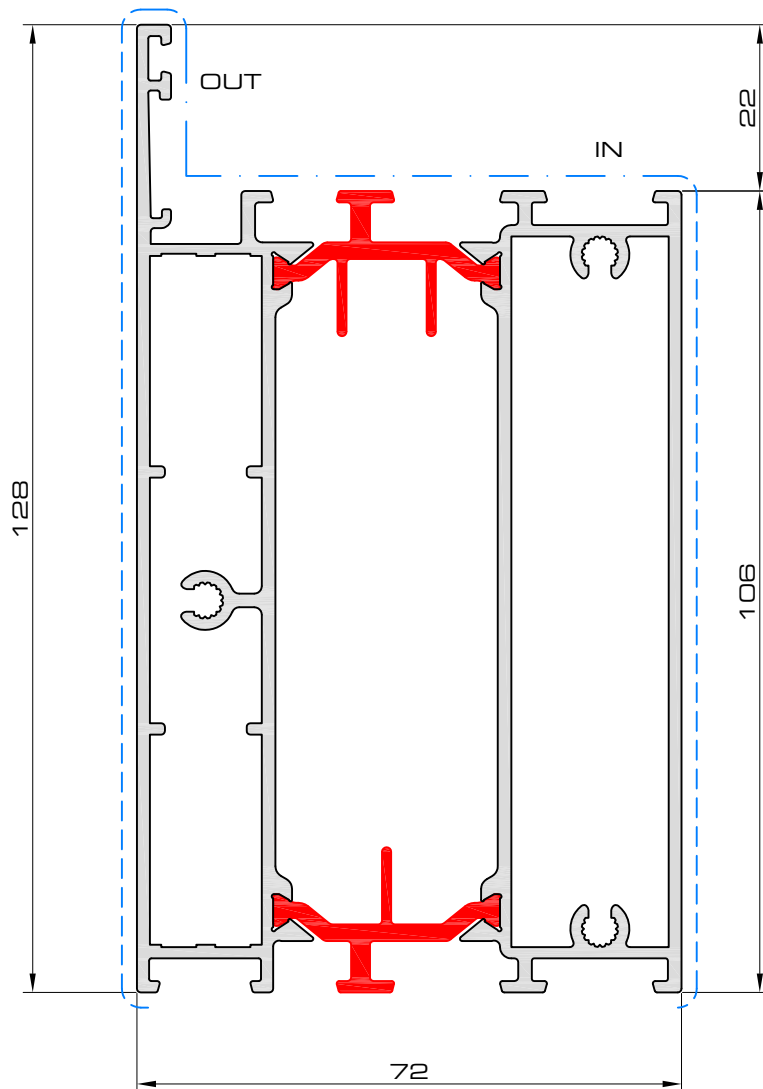

	$I_x = 74.8\text{cm}^4$
	$I_y = 138.5\text{cm}^4$
	$W_x = 19.39\text{cm}^3$
	$W_y = 19.25\text{cm}^3$



P-03-A108

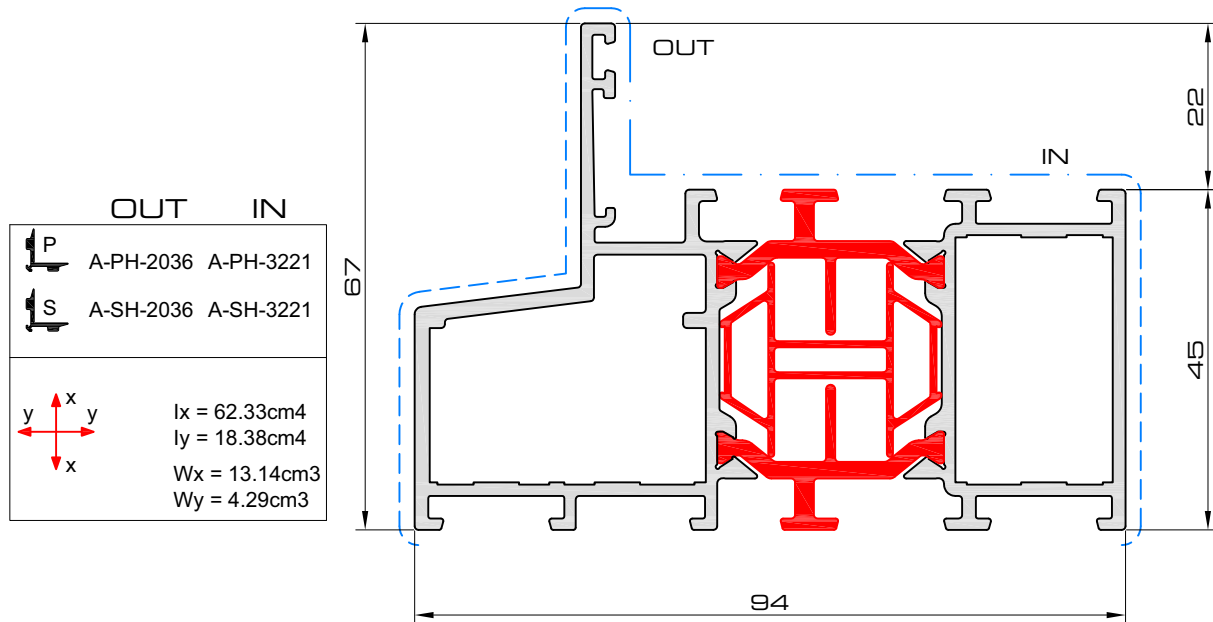

P-03-A109

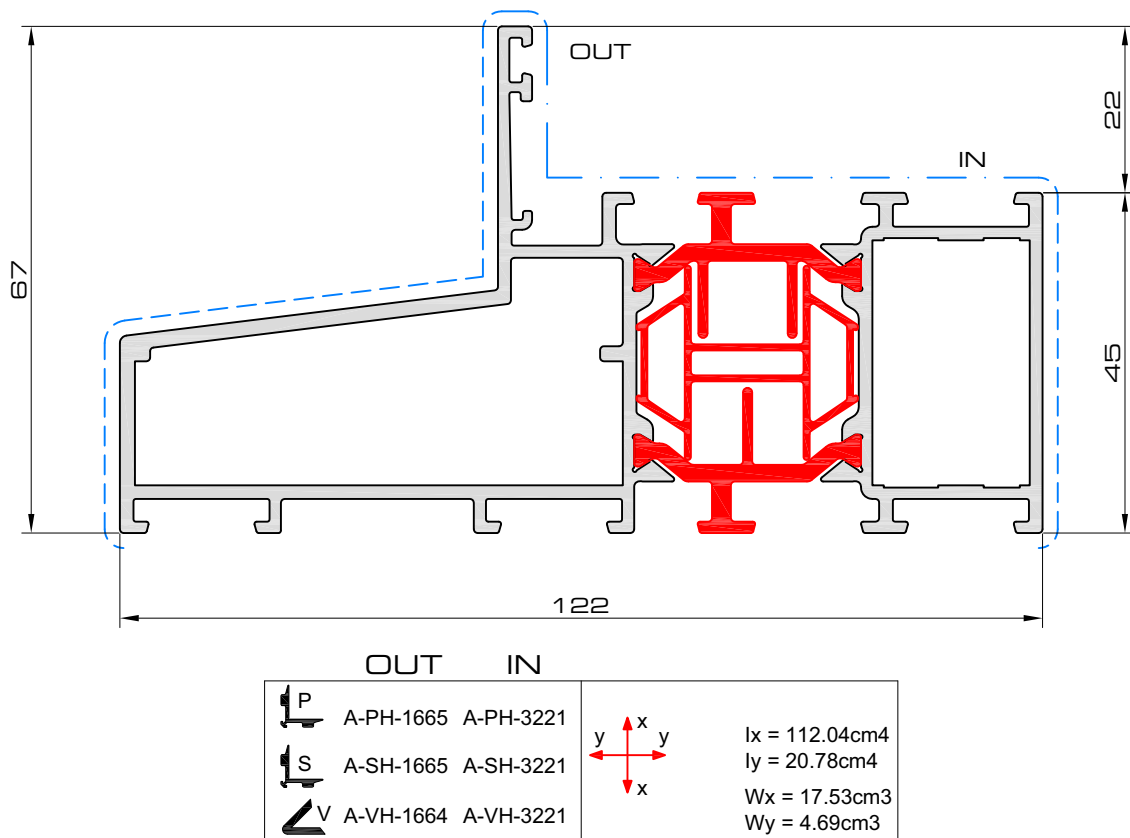

prof3









profielen - profils - profiles

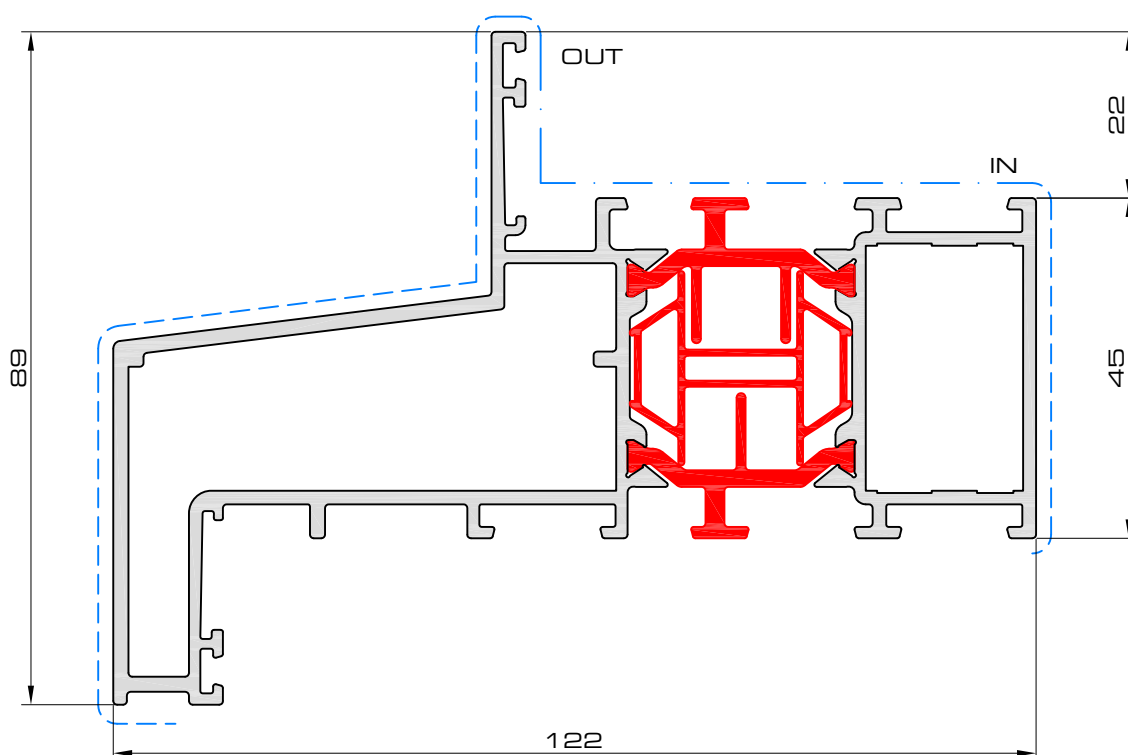

Triton 03

P-03-A110



	OUT	IN
 P	A-PH-1665	A-PH-3221
 S	A-SH-1662	A-SH-3221
 V	-	-
 V	A-VH-1664	A-VH-3221
	$I_x = 140.73\text{cm}^4$ $I_y = 33.03\text{cm}^4$ $W_x = 21.81\text{cm}^3$ $W_y = 6.81\text{cm}^3$	

prof19









profielen - profils - profiles

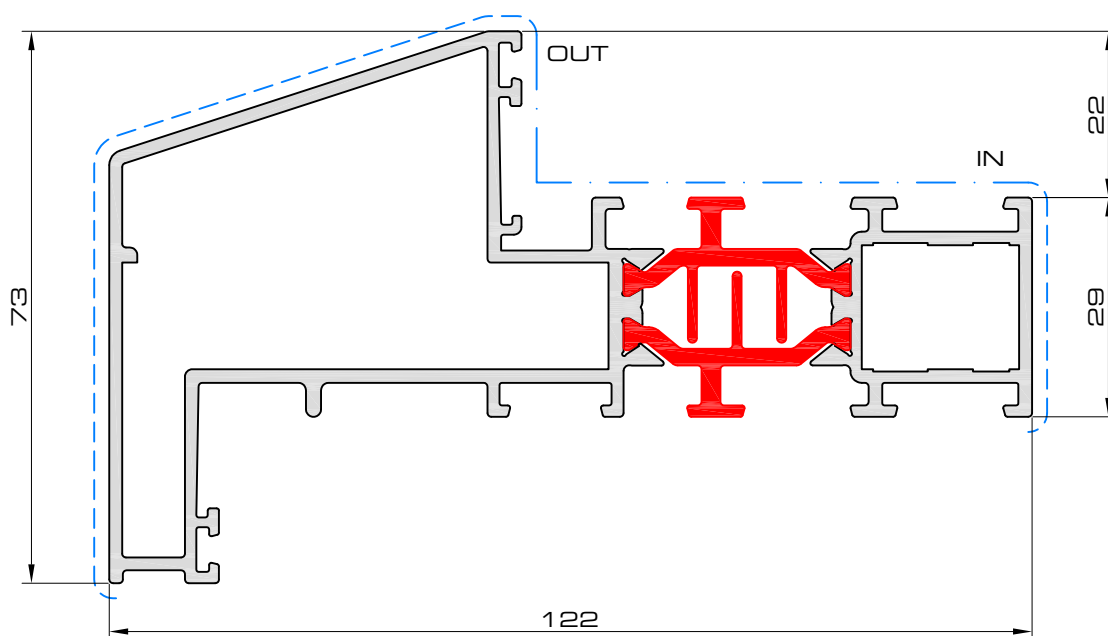

Triton 03

P-03-A1 15







	OUT	IN
 P	A-PH-1464	A-PH-1621
 S	A-SH-1465	A-SH-1621
	-	-
	-	-
	$I_x = 122.02\text{cm}^4$ $I_y = 23.2\text{cm}^4$ $W_x = 17.83\text{cm}^3$ $W_y = 6.26\text{cm}^3$	

prof20

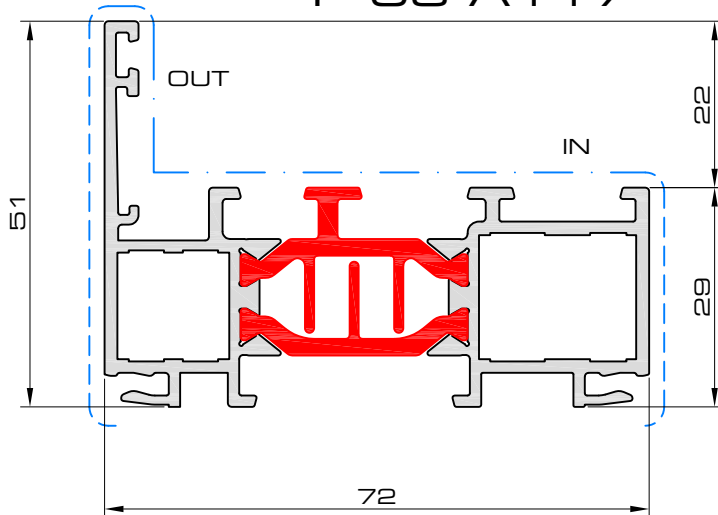





P-03-A1 17

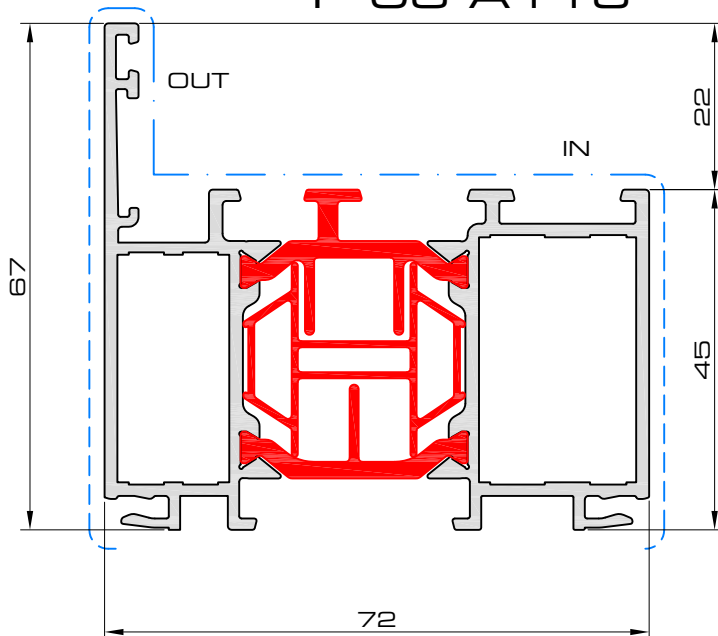

	OUT	IN
 P	A-PH-1415	A-PH-1621
 S	A-SH-1415	A-SH-1620
	$I_x = 30.28\text{cm}^4$ $I_y = 6.41\text{cm}^4$ $W_x = 7.58\text{cm}^3$ $W_y = 1.9\text{cm}^3$	

P-03-A1 18



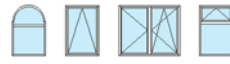

	OUT	IN
 P	A-PH-3015	A-PH-3221
 S	A-SH-3015	A-SH-3220
	$I_x = 38.61\text{cm}^4$ $I_y = 16.54\text{cm}^4$ $W_x = 9.78\text{cm}^3$ $W_y = 3.96\text{cm}^3$	

prof56

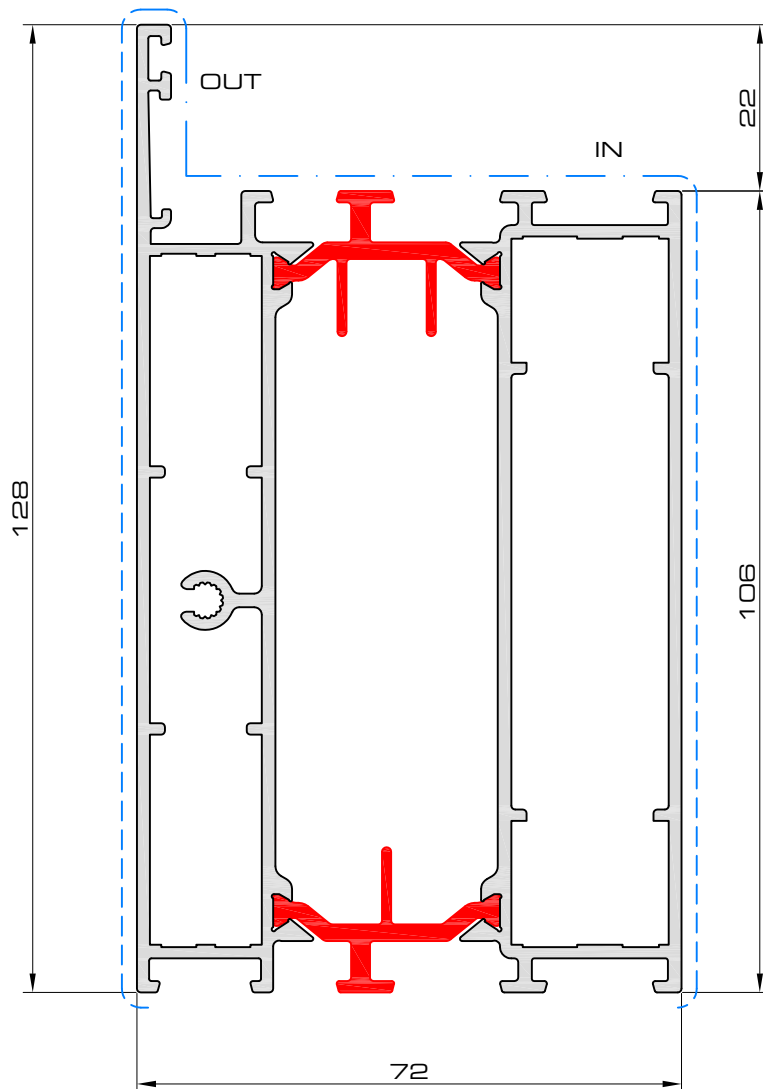

P-03-A123



	OUT	IN
 T	A-TV-065	A-TV-001
	$I_x = 73.1 \text{ cm}^4$	$I_y = 132.9 \text{ cm}^4$
	$W_x = 18.66 \text{ cm}^3$	$W_y = 18.49 \text{ cm}^3$

prof60



profielen - profils - profiles

P-03-A200

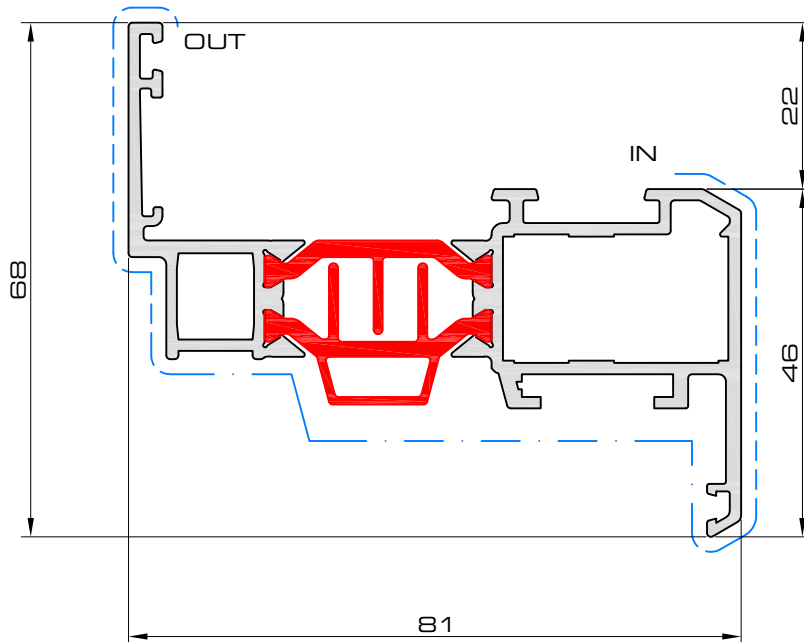

	OUT	IN
P	A-PH-1110	A-PH-1630
S	A-SH-1110	A-SH-1630
H	-	-
V	A-VH-1110	A-VH-1630
	$I_x = 40.97\text{cm}^4$ $I_y = 8.41\text{cm}^4$ $W_x = 9.52\text{cm}^3$ $W_y = 2.4\text{cm}^3$	

P-03-A201

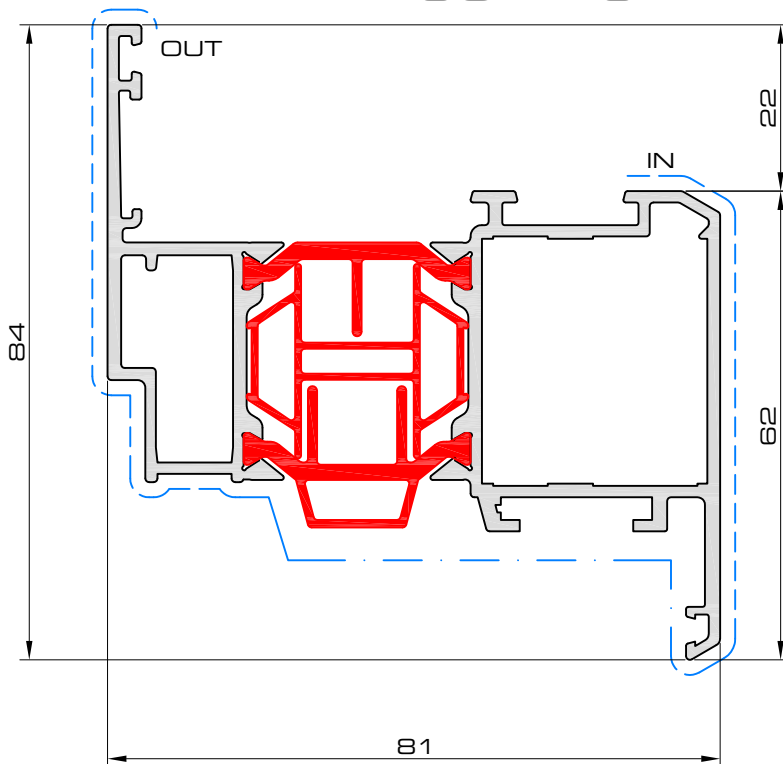





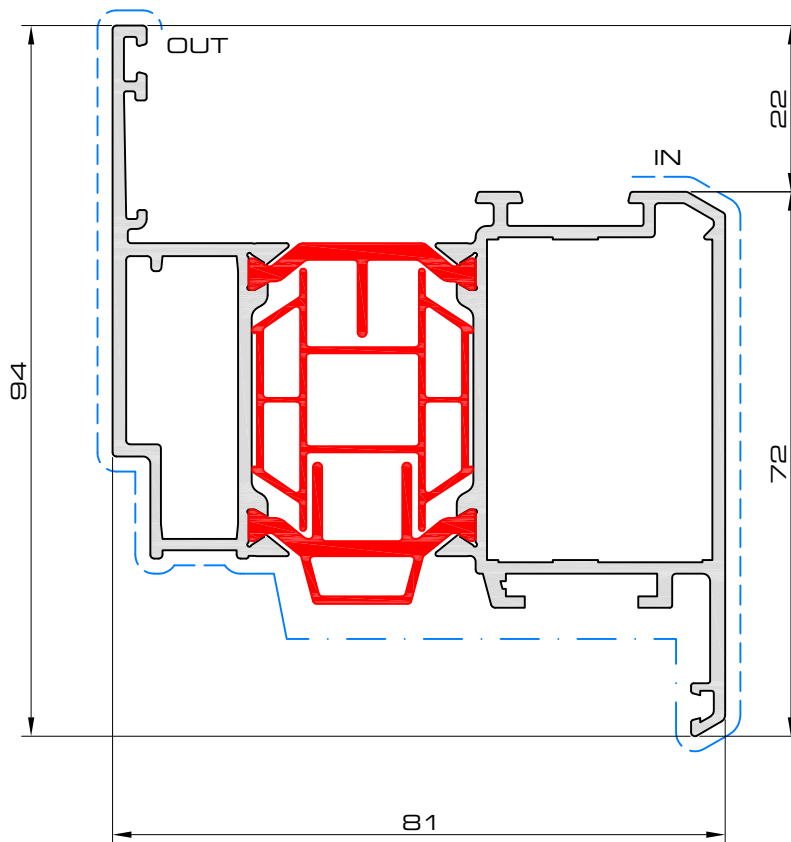

	OUT	IN
P	A-PH-2710	A-PH-3230
S	A-SH-2710	A-SH-3230
H	-	-
V	-	-
	$I_x = 52.89\text{cm}^4$ $I_y = 19.81\text{cm}^4$ $W_x = 12.85\text{cm}^3$ $W_y = 4.62\text{cm}^3$	

prof4



P-03-A202



	OUT	IN
 P	A-PH-3710	A-PH-4230
 S	A-SH-3710	A-SH-4230
 H	-	-
 V	-	-
	$I_x = 59.49\text{cm}^4$ $I_y = 30.73\text{cm}^4$ $W_x = 14.64\text{cm}^3$ $W_y = 6.42\text{cm}^3$	

prof5



profielen - profils - profiles

P-03-A210

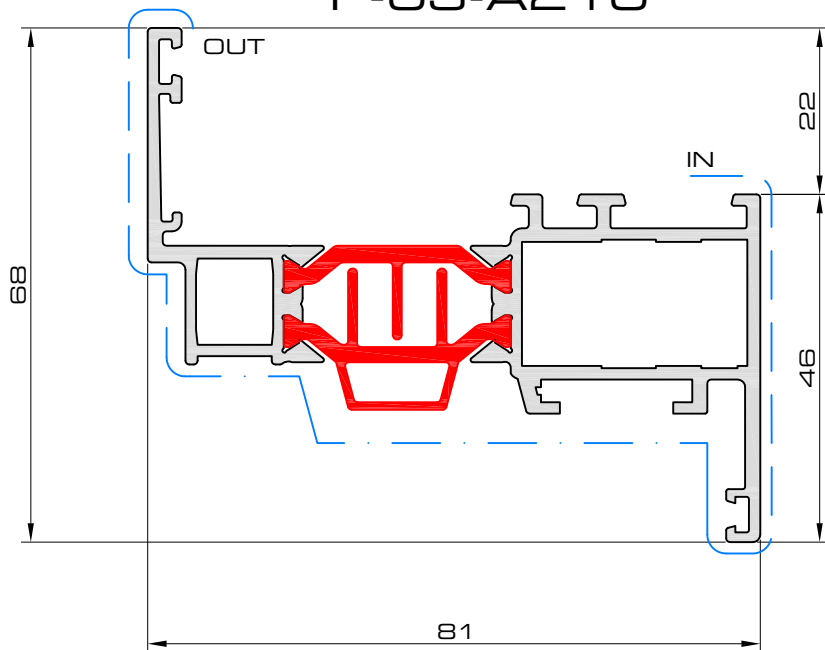

Variant! **Planea**

	OUT	IN
	A-PH-1110	A-PH-1630
	A-SH-1110	A-SH-1630
	-	-
	A-VH-1110	A-VH-1630
	$I_x = 41.93\text{cm}^4$ $I_y = 8.58\text{cm}^4$ $W_x = 9.58\text{cm}^3$ $W_y = 2.42\text{cm}^3$	

P-03-A211

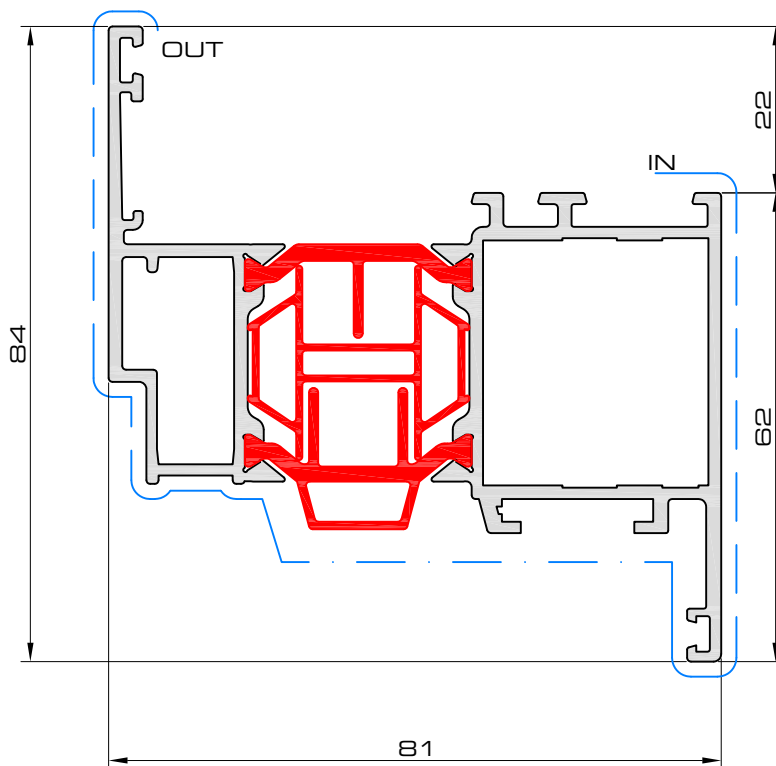

	OUT	IN
	A-PH-2710	A-PH-3230
	A-SH-2710	A-SH-3230
	-	-
	-	-
	$I_x = 54\text{cm}^4$ $I_y = 20.5\text{cm}^4$ $W_x = 12.93\text{cm}^3$ $W_y = 4.77\text{cm}^3$	





prof21

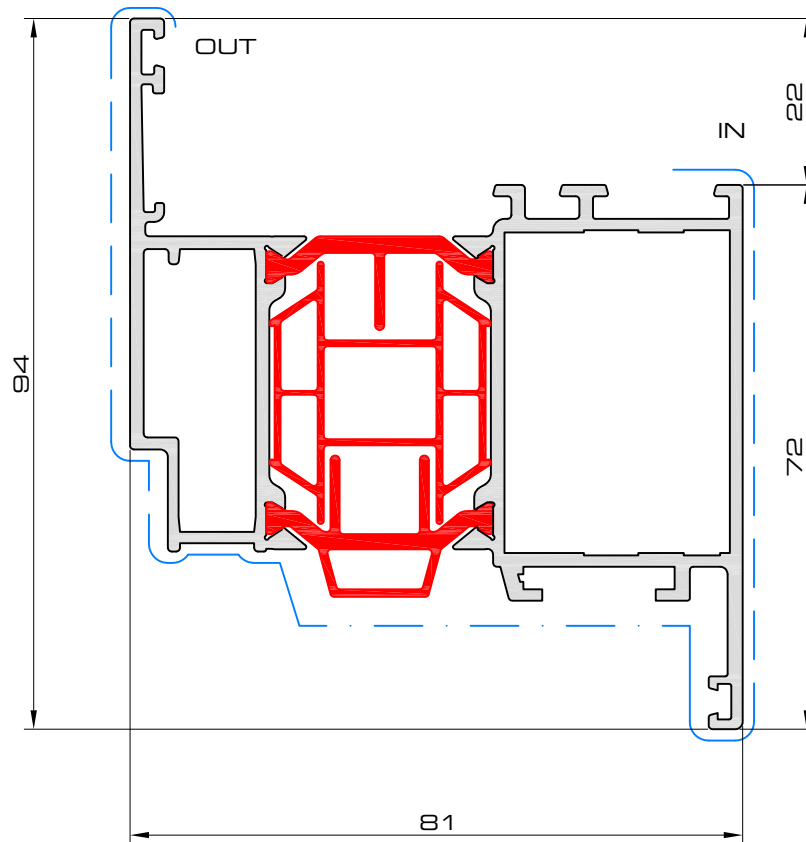

Variant! Planea

P-03-A212



	OUT	IN
 P	A-PH-3710	A-PH-4230
 S	A-SH-3710	A-SH-4230
	-	-
	-	-
	$I_x = 60.64\text{cm}^4$ $I_y = 31.73\text{cm}^4$ $W_x = 14.7\text{cm}^3$ $W_y = 6.64\text{cm}^3$	

prof28



profielen - profils - profiles

P-03-A230B

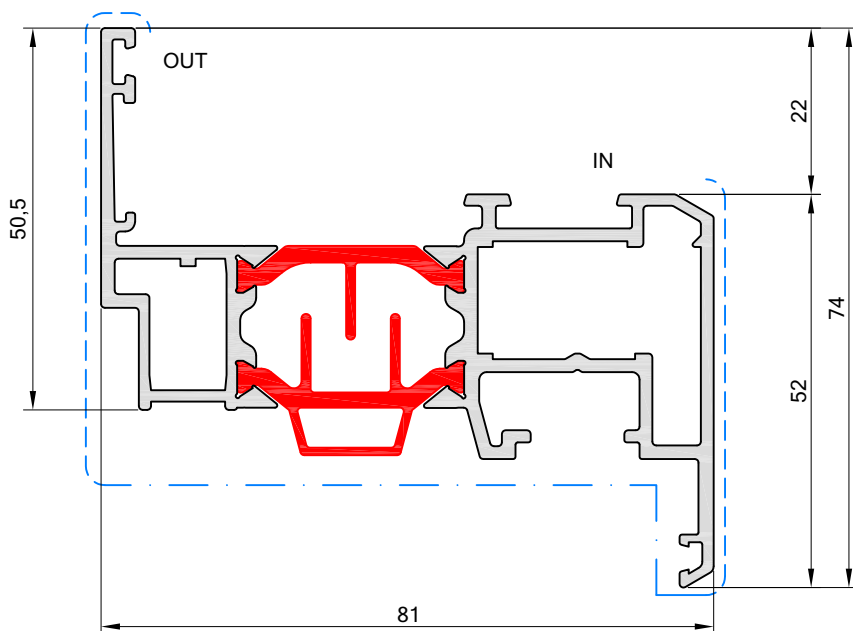

	OUT	IN
P	A-PH-1610	A-PH-1430
S	-	-
V	-	-
	$I_x = 47.54\text{cm}^4$ $I_y = 11.85\text{cm}^4$ $W_x = 11.06\text{cm}^3$ $W_y = 3.12\text{cm}^3$	

P-03-A231B

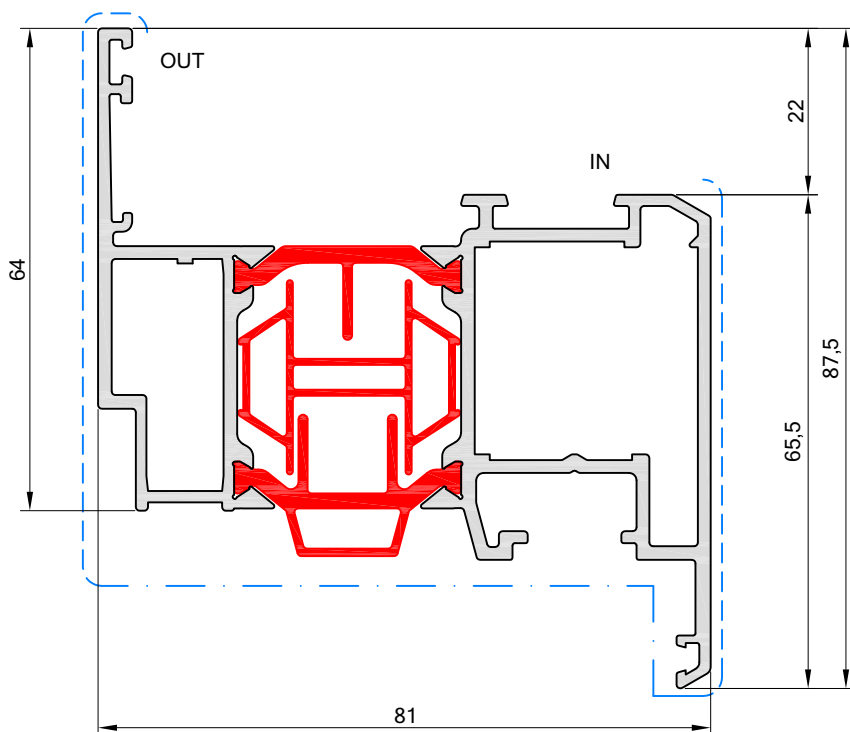

	OUT	IN
P	A-PH-3010	A-PH-2730
S	-	-
V	-	-
	$I_x = 56.41\text{cm}^4$ $I_y = 23.25\text{cm}^4$ $W_x = 13.42\text{cm}^3$ $W_y = 5.19\text{cm}^3$	

prof44

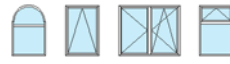

P-03-A240B

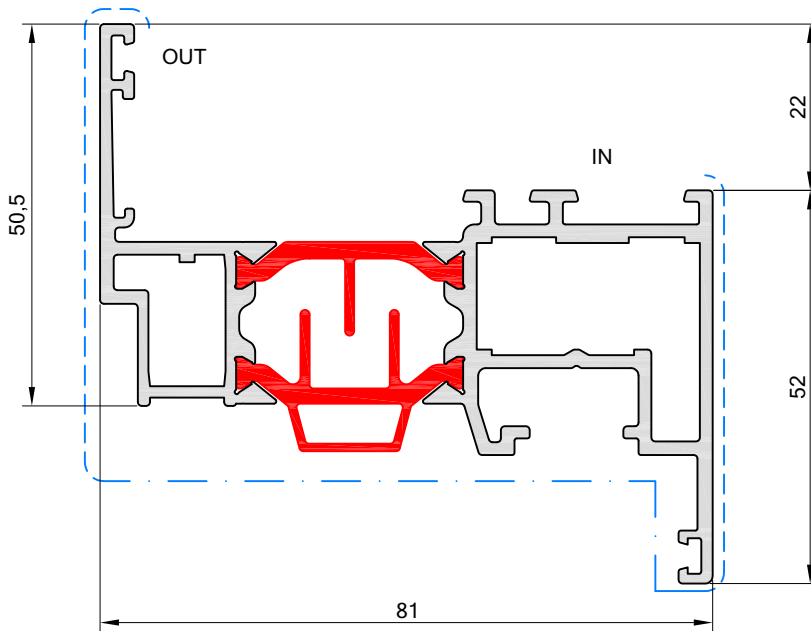

	OUT	IN
P	A-PH-1610	A-PH-1430
S	-	-
V	-	-
	$I_x = 48.45\text{cm}^4$ $I_y = 12.22\text{cm}^4$ $W_x = 11.14\text{cm}^3$ $W_y = 3.22\text{cm}^3$	

P-03-A241B

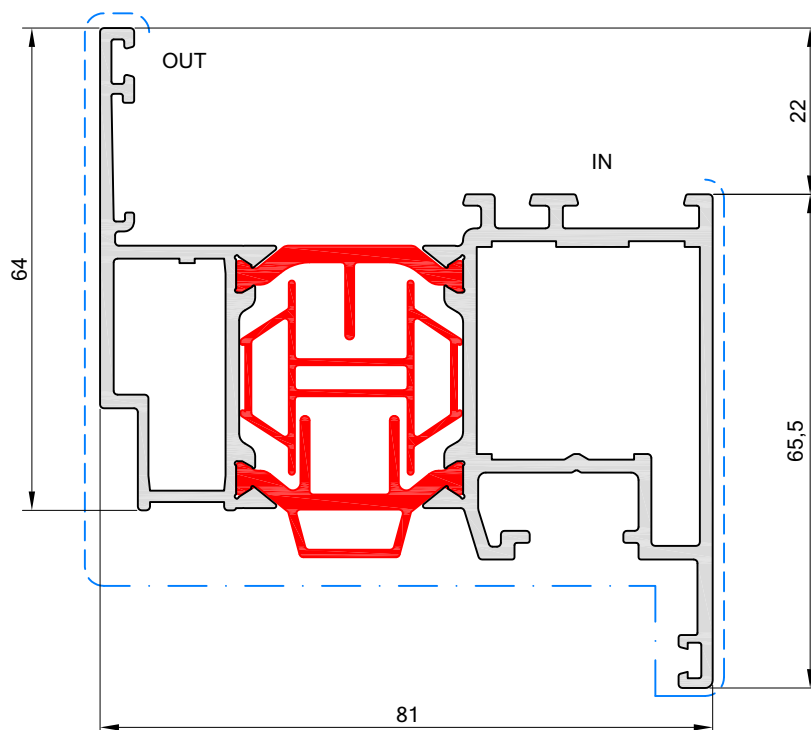

	OUT	IN
P	A-PH-3010	A-PH-2730
S	-	-
V	-	-
	$I_x = 57.38\text{cm}^4$ $I_y = 23.91\text{cm}^4$ $W_x = 13.49\text{cm}^3$ $W_y = 5.34\text{cm}^3$	

prof47



profielen - profils - profiles



Triton 03

P-03-A430B

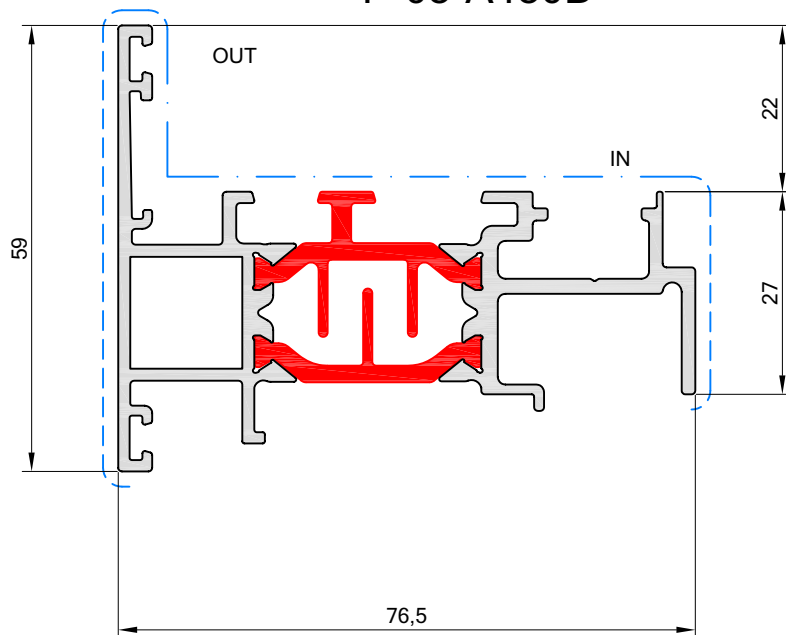

	OUT	IN
	-	-
	-	-
	-	-
	$I_x = 34.22\text{cm}^4$ $I_y = 6.98\text{cm}^4$ $W_x = 7.62\text{cm}^3$ $W_y = 2.02\text{cm}^3$	

prof45

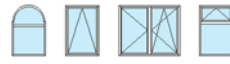

P-03-A116

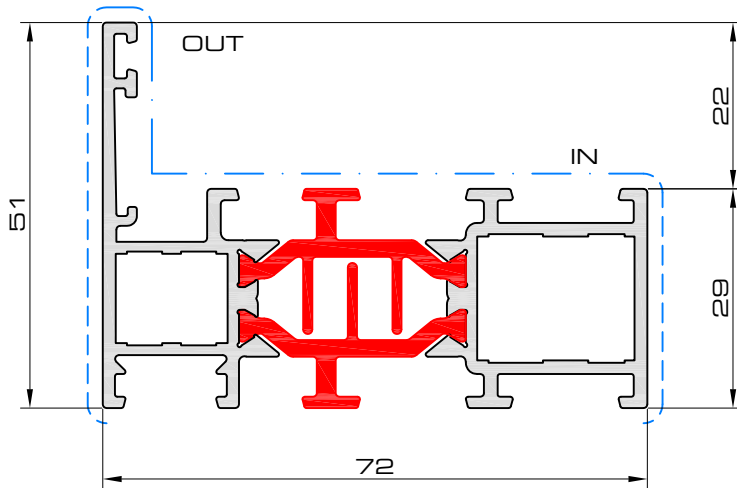

	OUT	IN
	A-PH-1115	A-PH-1621
	A-GH-1115	A-SH-1621
	A-TV-064	A-TV-001
	A-TV-057	A-TV-005
	-	A-VH-1621
	A-VT-1115	A-VT-1621
	$I_x = 30.3\text{cm}^4$ $I_y = 6.12\text{cm}^4$ $W_x = 7.64\text{cm}^3$ $W_y = 1.83\text{cm}^3$	

P-03-A300

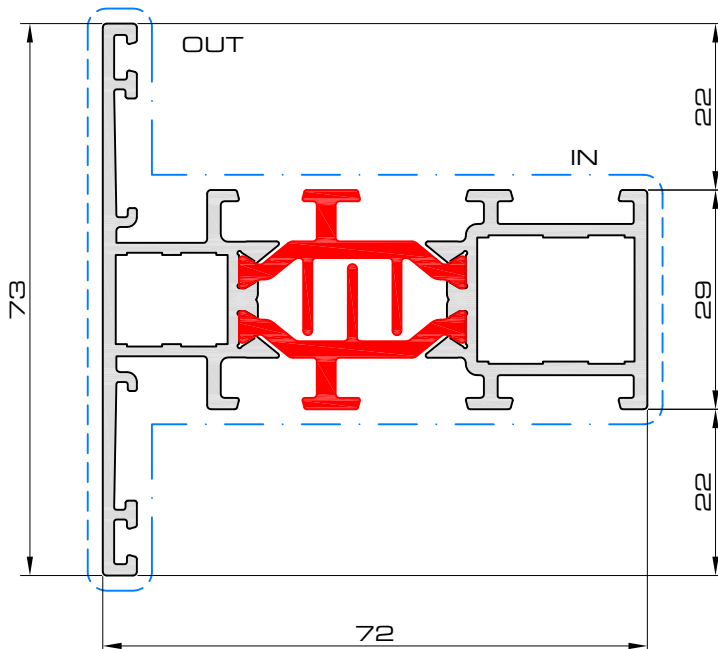

	OUT	IN
	A-PH-1115	A-PH-1621
	A-GH-1115	A-SH-1621
	A-TV-064	A-TV-001
	A-TV-057	A-TV-005
	-	A-VH-1621
	A-VT-1115	A-VT-1621
	$I_x = 34.65\text{cm}^4$ $I_y = 10.22\text{cm}^4$ $W_x = 8.07\text{cm}^3$ $W_y = 2.8\text{cm}^3$	

prof7



profielen - profils - profiles

P-03-A301

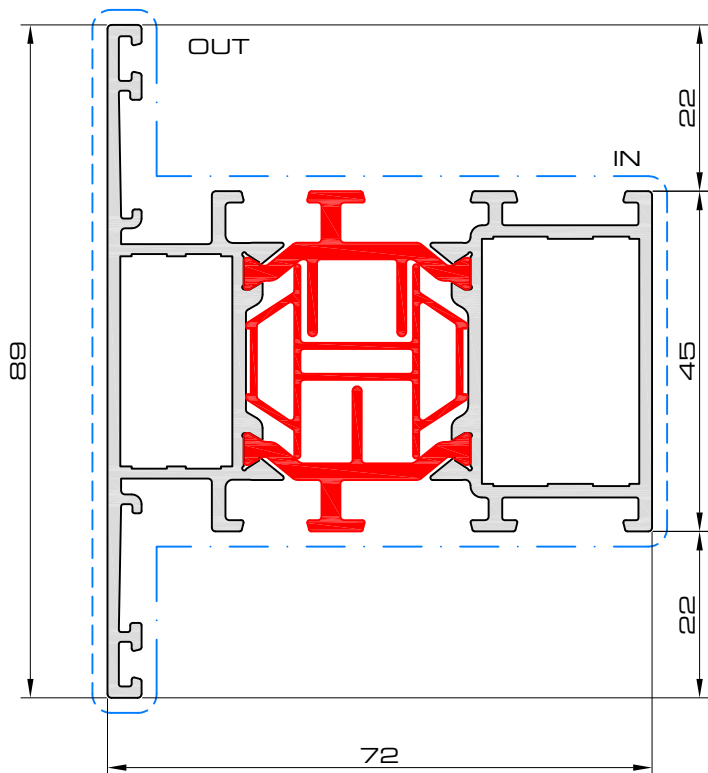

	OUT	IN
	A-PH-2715	A-PH-3221
	A-PH-2715	A-SH-3221
	A-TV-065	A-TV-002
	-	A-VH-3221
	A-VT-2715L	A-VT-3221L
	A-VT-2715R	A-VT-3221R

	$I_x = 43.19\text{cm}^4$ $I_y = 22.63\text{cm}^4$ $W_x = 10.31\text{cm}^3$ $W_y = 5.09\text{cm}^3$
--	---

P-03-A302

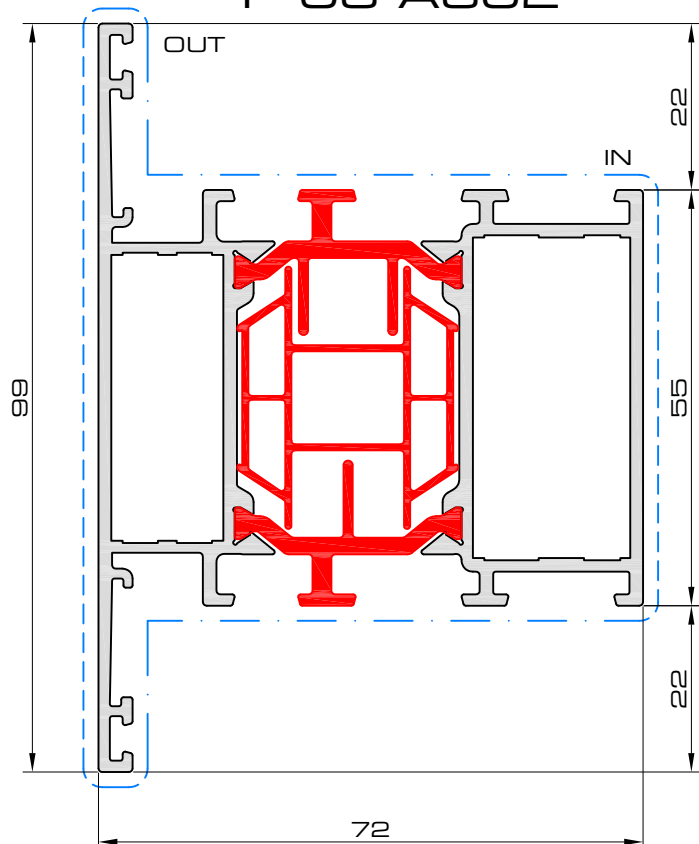

	OUT	IN
	A-PH-3715	A-PH-4221
	A-PH-3715	A-SH-4221
	A-TV-066	A-TV-003
	-	A-VH-4221

	$I_x = 48.4\text{cm}^4$ $I_y = 34.25\text{cm}^4$ $W_x = 11.68\text{cm}^3$ $W_y = 6.92\text{cm}^3$
--	--

prof8



profielen - profils - profiles



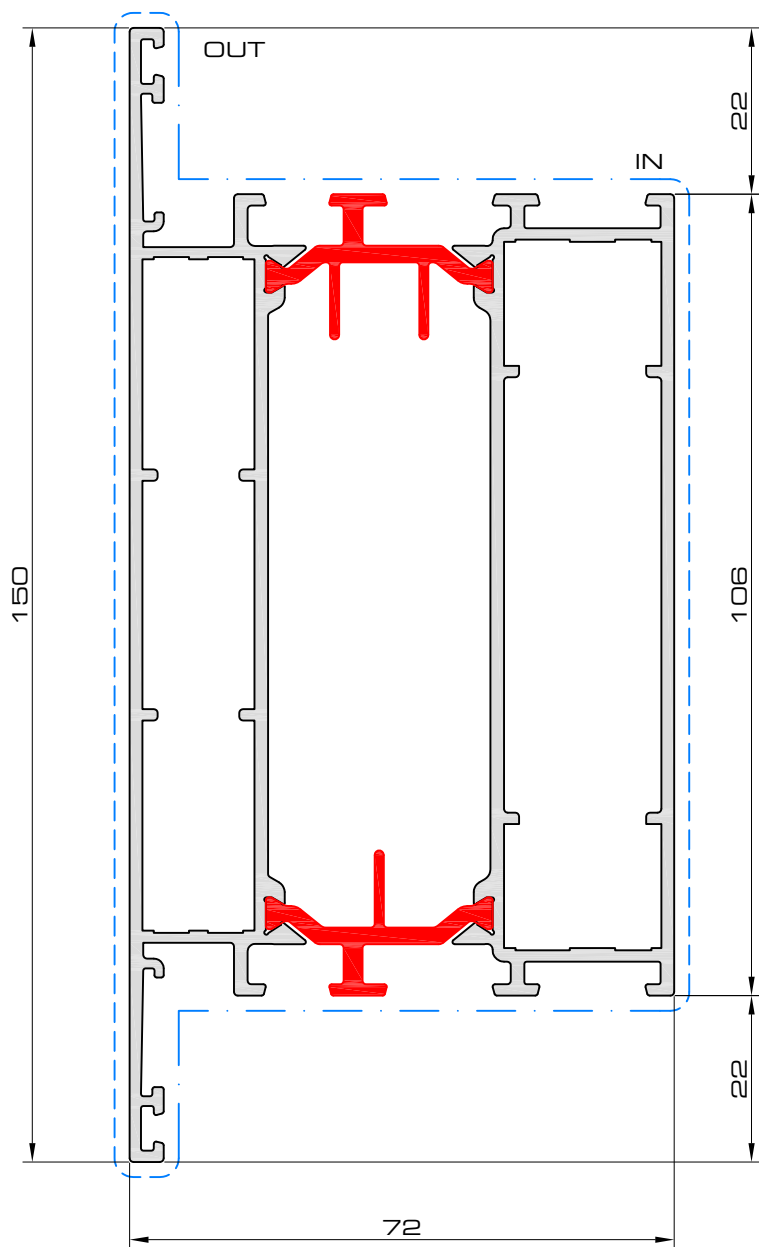

P-03-A303

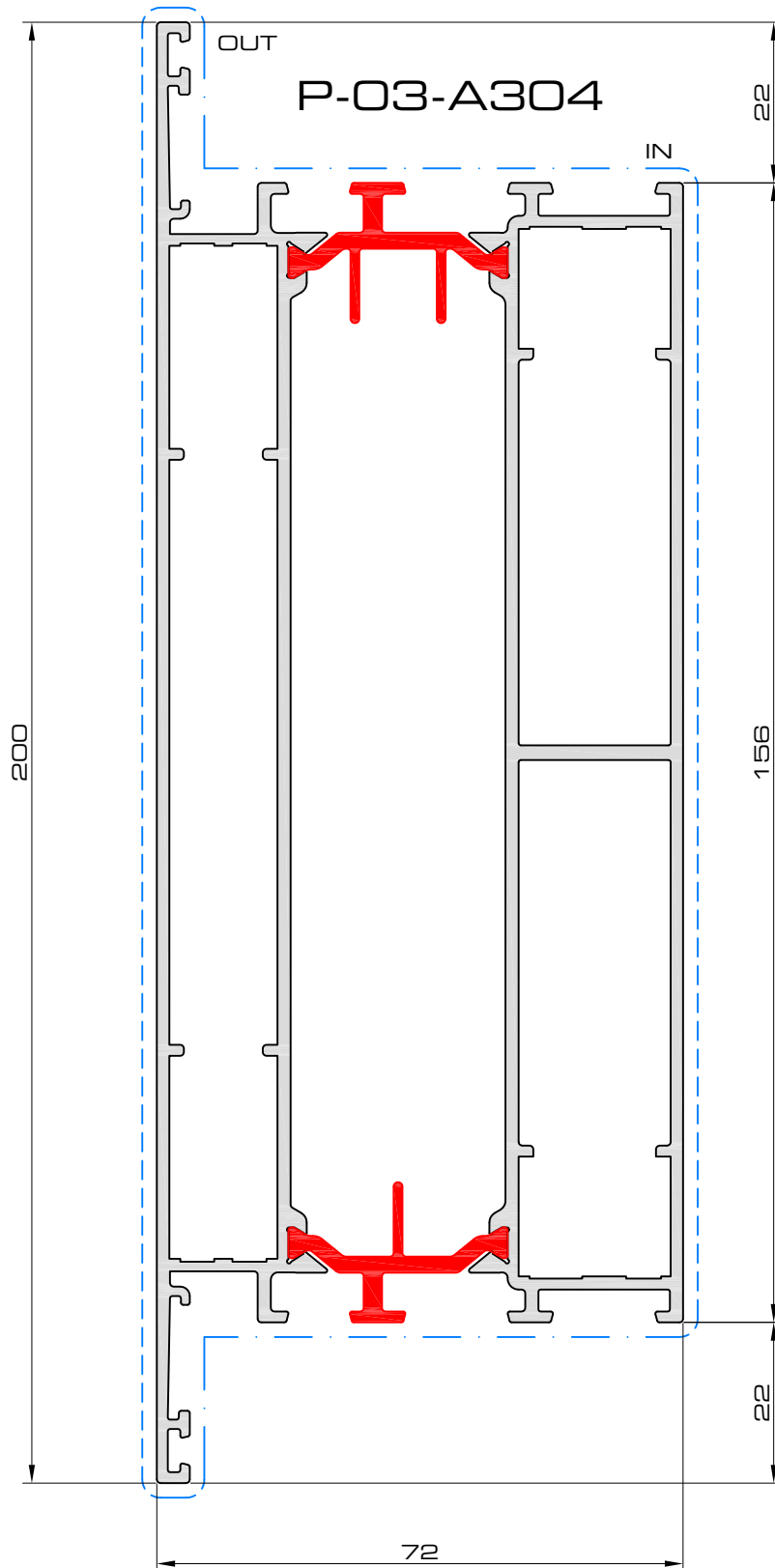
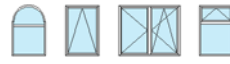

	OUT	IN
P	-	-
S	-	-
TV	A-TV-065	A-TV-001
	$I_x = 76.43\text{cm}^4$ $I_y = 154.78\text{cm}^4$ $W_x = 19.1\text{cm}^3$ $W_y = 20.64\text{cm}^3$	

prof9



	OUT	IN
 P	-	-
 S	-	-
 A-TV-065	A-TV-065	A-TV-001
	$I_x = 105.27\text{cm}^4$ $I_y = 406.87\text{cm}^4$ $W_x = 27.25\text{cm}^3$ $W_y = 40.67\text{cm}^3$	

prof17



profielen - profils - profiles



P-03-A305

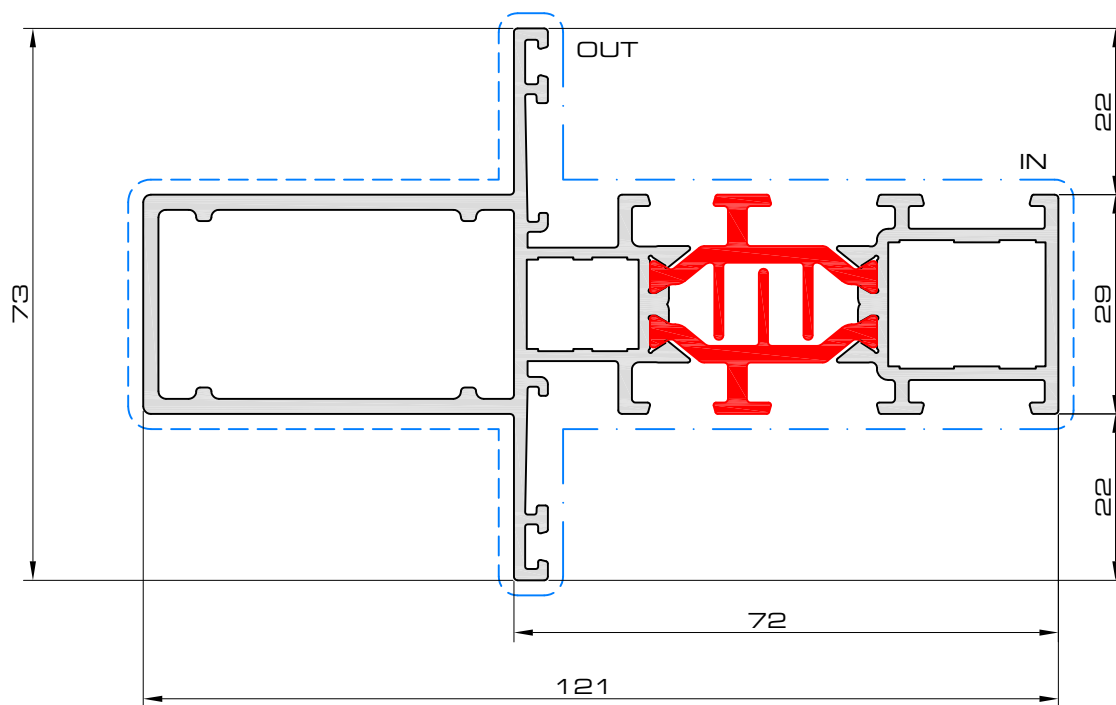

	OUT	IN
	-	-
	-	-
	A-TV-064	A-TV-001
	A-TV-057	A-TV-005
	$I_x = 98.38\text{cm}^4$ $I_y = 14.28\text{cm}^4$ $W_x = 15.61\text{cm}^3$ $W_y = 3.91\text{cm}^3$	

prof10



P-03-A306

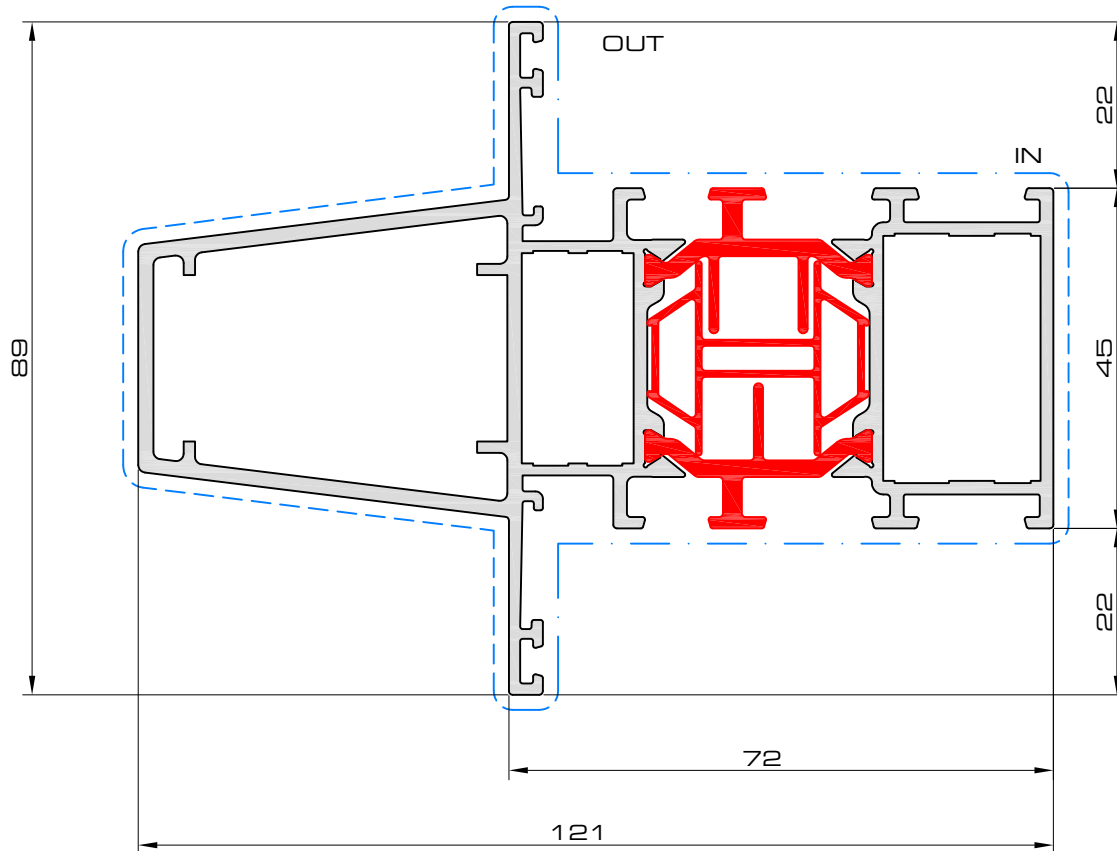

	OUT	IN
	-	-
	-	-
	A-TV-065	A-TV-002
	$I_x = 115.39\text{cm}^4$ $I_y = 29.2\text{cm}^4$ $W_x = 18.96\text{cm}^3$ $W_y = 6.56\text{cm}^3$	

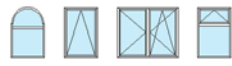

profielen - profils - profiles

P-03-A309

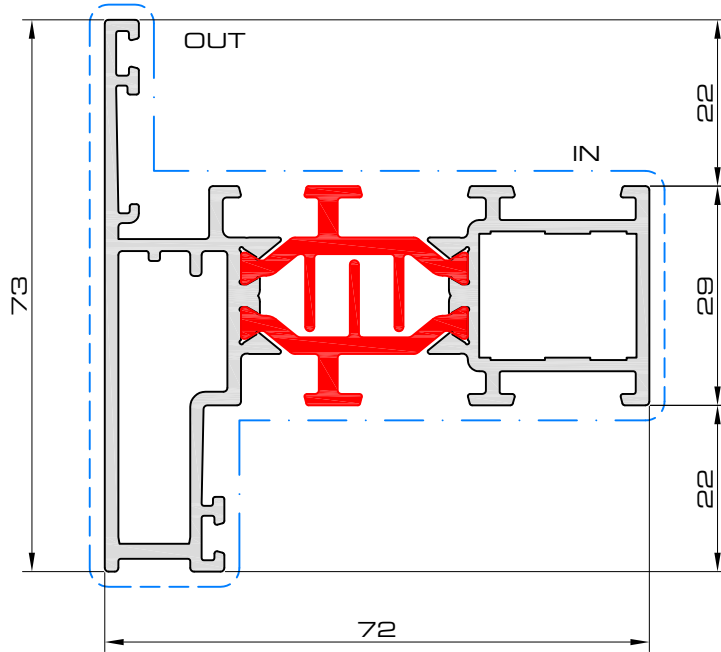

	OUT	IN
	A-PH-3709	A-PH-1621
	A-SH-3709	A-SH-1621
	-	A-VH-1630
	$I_x = 35.70\text{cm}^4$ $I_y = 14.70\text{cm}^4$ $W_x = 8.04\text{cm}^3$ $W_y = 3.75\text{cm}^3$	

P-03-A319

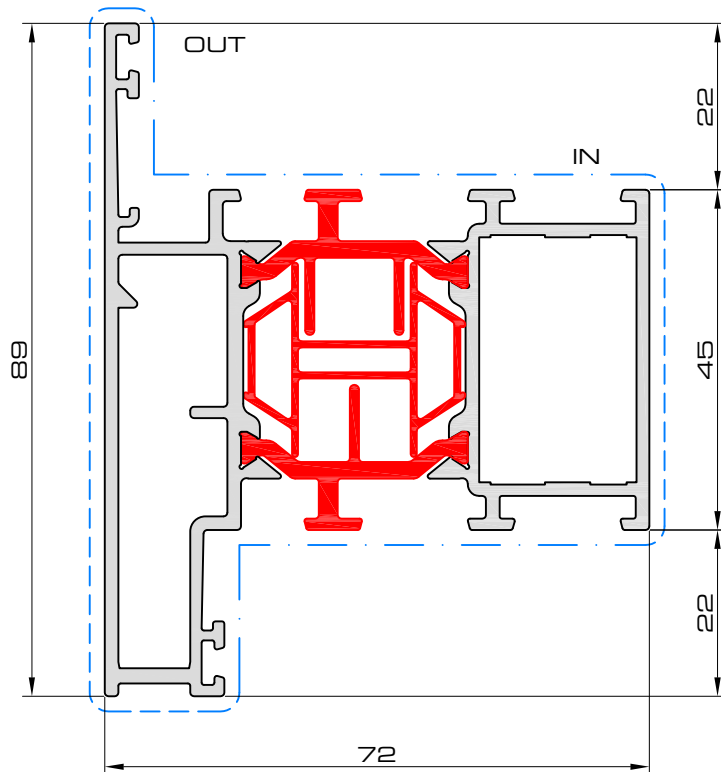

	OUT	IN
	A-PH-4709	A-PH-3221
	A-SH-4709	A-SH-3221
	-	A-VH-3221
	$I_x = 44.87\text{cm}^4$ $I_y = 29.89\text{cm}^4$ $W_x = 10.32\text{cm}^3$ $W_y = 6.34\text{cm}^3$	

prof43

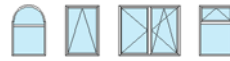

P-03-A310

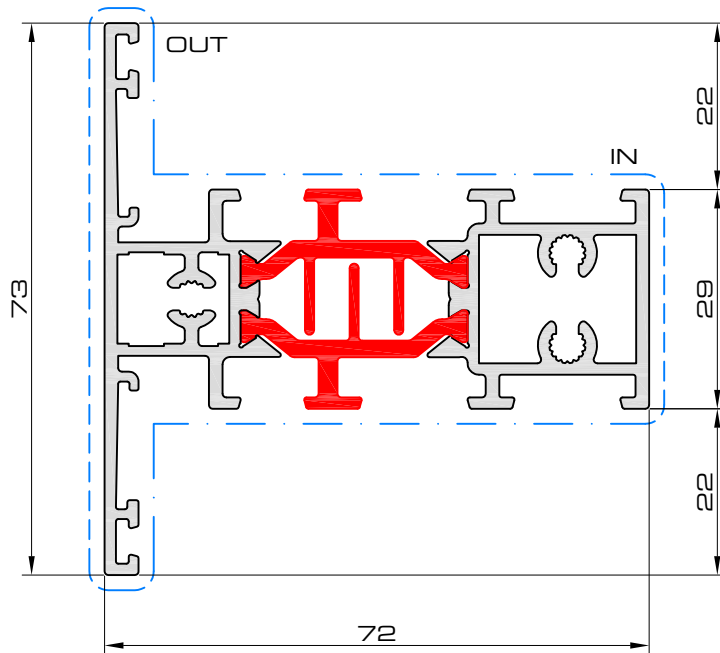

	$I_x = 37.92\text{cm}^4$
	$I_y = 10.34\text{cm}^4$
	$W_x = 9.28\text{cm}^3$
	$W_y = 2.83\text{cm}^3$

P-03-A311

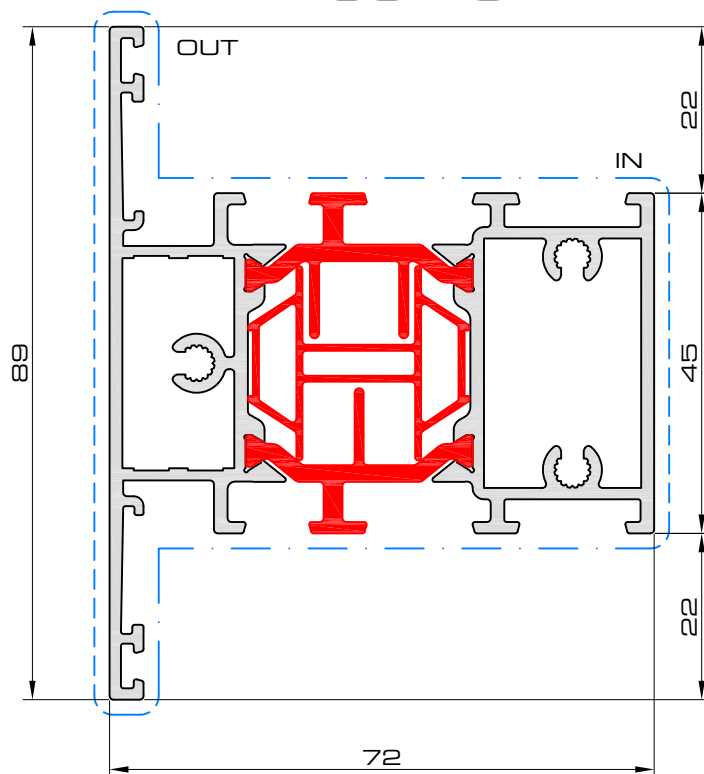

	$I_x = 46.29\text{cm}^4$
	$I_y = 23.26\text{cm}^4$
	$W_x = 11.5\text{cm}^3$
	$W_y = 5.23\text{cm}^3$

prof11



profielen - profils - profiles

Triton 03

P-03-A312

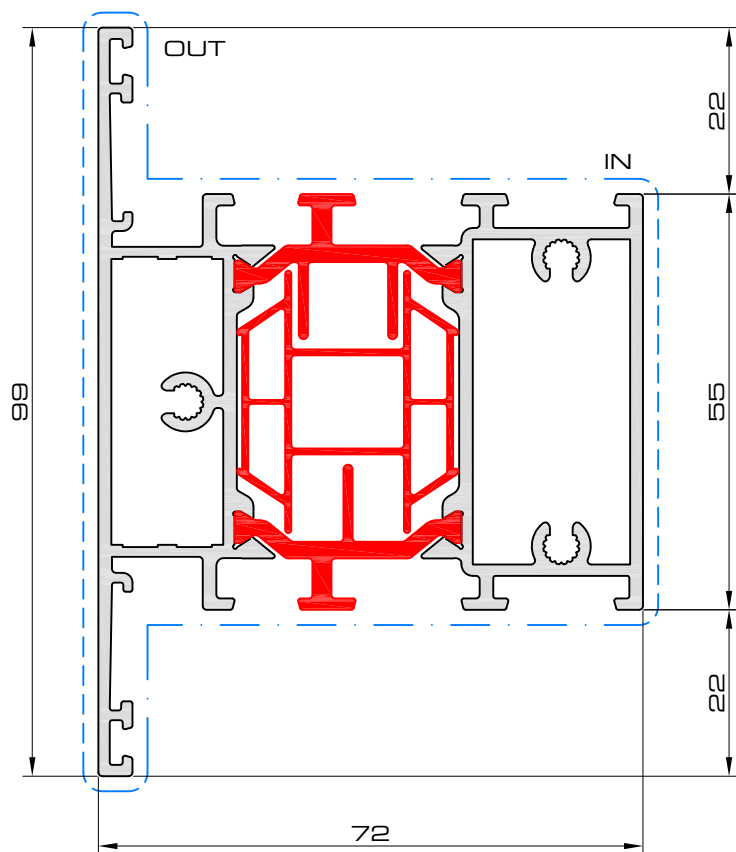

	$I_x = 51.43\text{cm}^4$
	$I_y = 35.42\text{cm}^4$
	$W_x = 12.86\text{cm}^3$
	$W_y = 7.16\text{cm}^3$

prof12

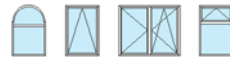

P-03-A315

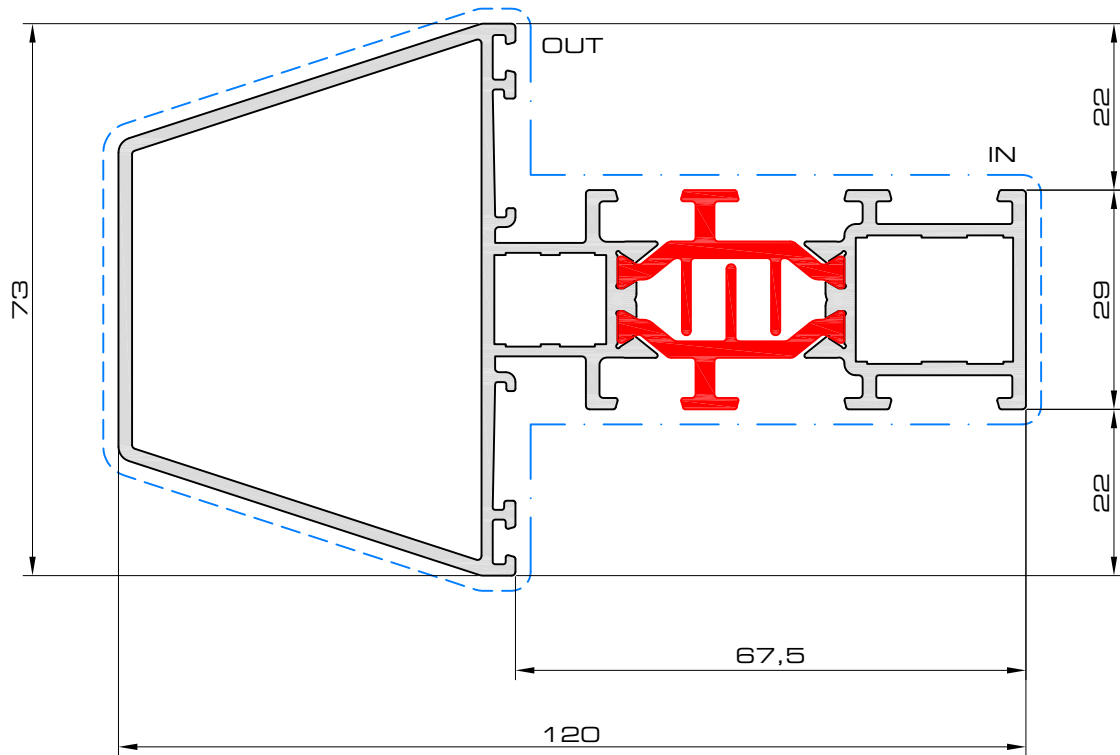

	OUT	IN
	-	-
	-	-
	A-TV-064	A-TV-001
	A-TV-057	A-TV-005
	$I_x = 99.32\text{cm}^4$ $I_y = 25.46\text{cm}^4$ $W_x = 15.76\text{cm}^3$ $W_y = 6.98\text{cm}^3$	

prof13



profielen - profils - profiles

P-03-A320

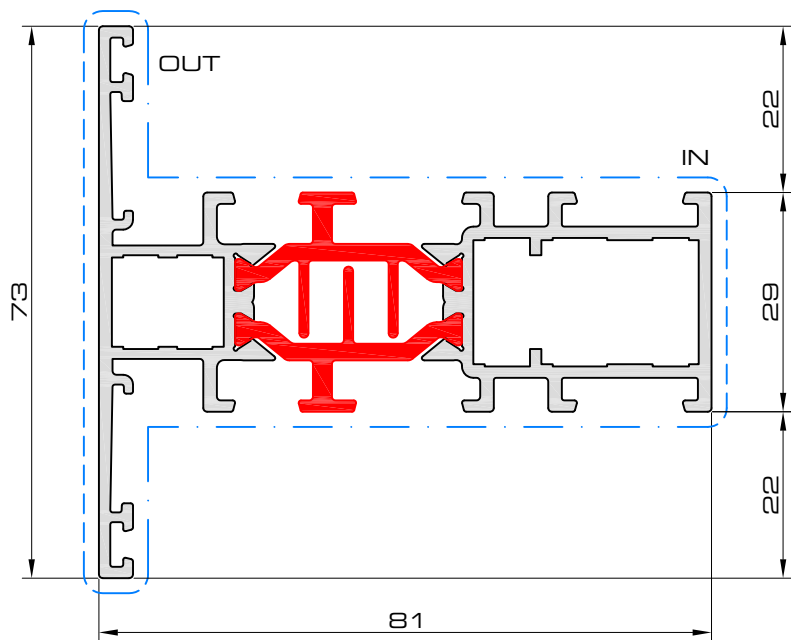

	OUT	IN
	A-TV-064	A-TV-001
	A-TV-057	A-TV-005
	A-VT-1115	A-VT-1621
	$I_x = 39.72\text{cm}^4$ $I_y = 8.86\text{cm}^4$ $W_x = 9.11\text{cm}^3$ $W_y = 2.8\text{cm}^3$	

P-03-A321

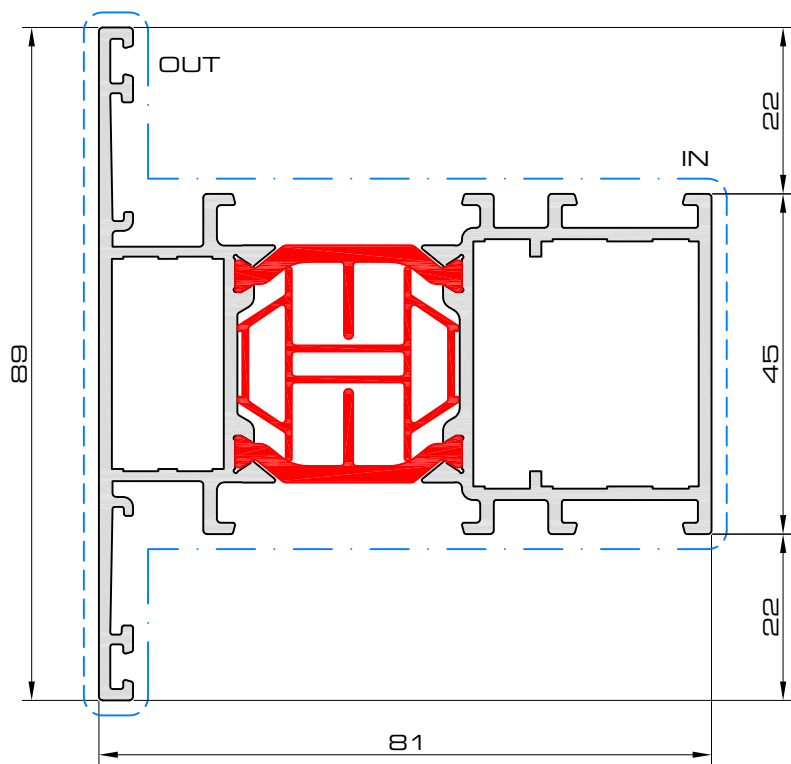

	OUT	IN
	A-TV-065	A-TV-002
	A-VT-2715L	A-VT-3221L
	A-VT-2715R	A-VT-3221R
	$I_x = 56.88\text{cm}^4$ $I_y = 24.29\text{cm}^4$ $W_x = 12.18\text{cm}^3$ $W_y = 5.46\text{cm}^3$	

prof22

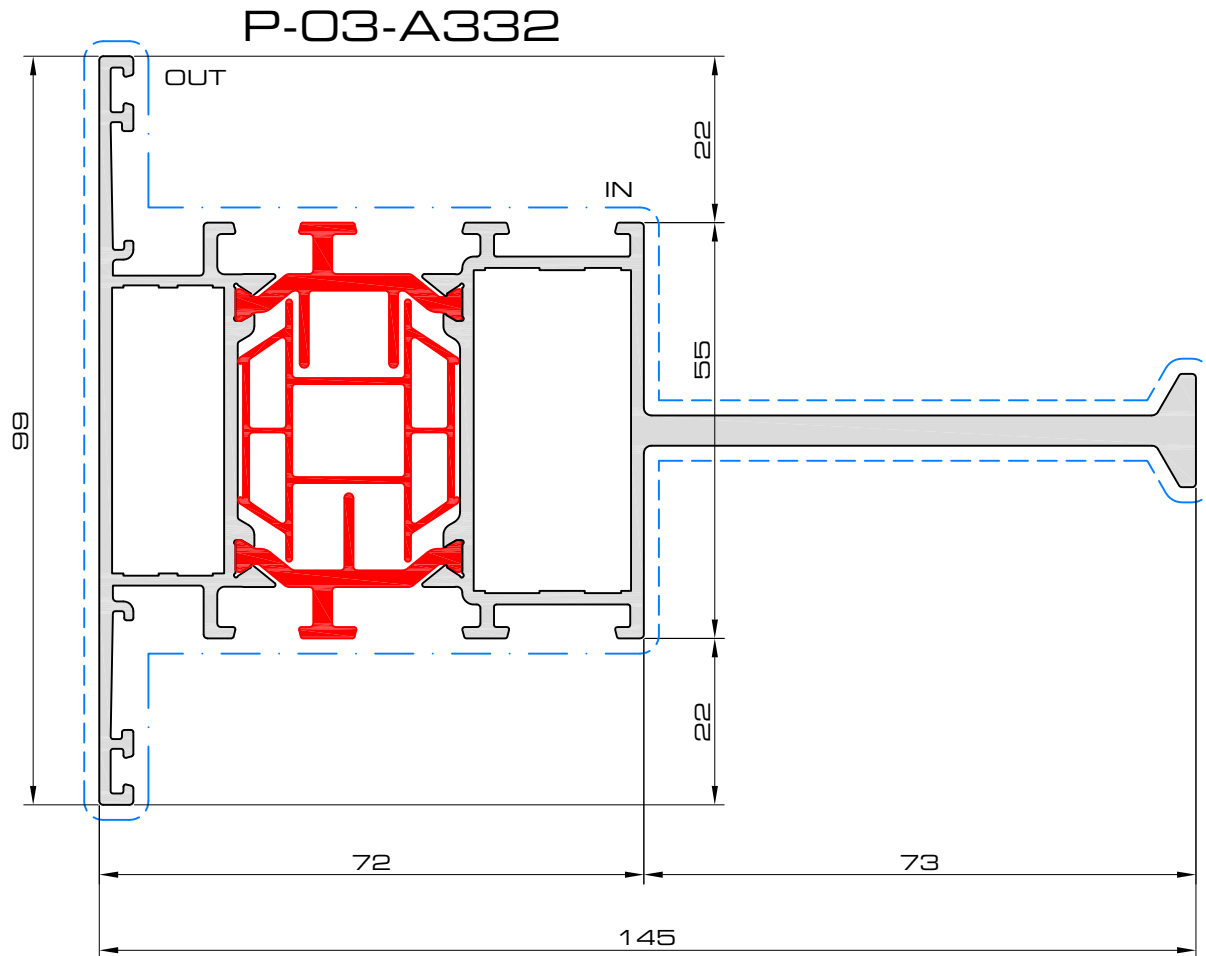
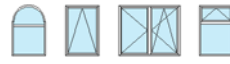

	OUT	IN
	-	-
	-	-
	A-TV-066	A-TV-003
	$I_x = 216.15 \text{cm}^4$ $I_y = 34.38 \text{cm}^4$ $W_x = 24.73 \text{cm}^3$ $W_y = 6.95 \text{cm}^3$	

prof55



profielen - profils - profiles

Triton 03

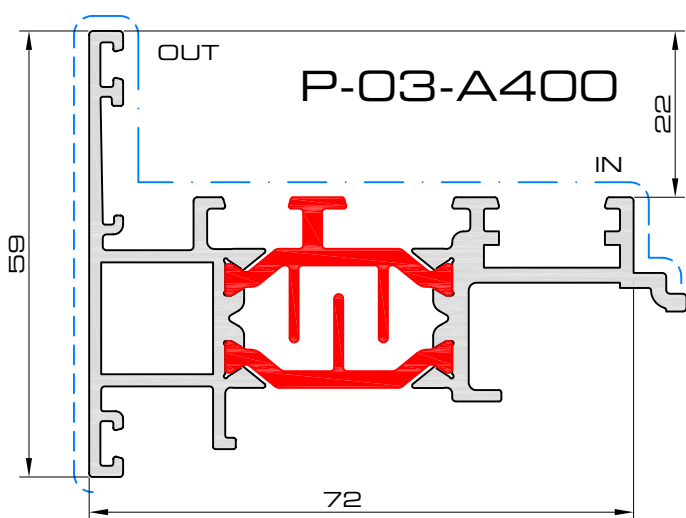





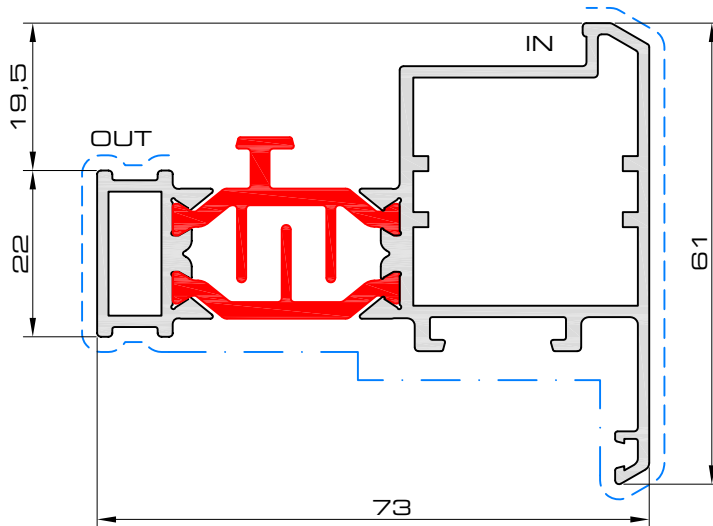

	$I_x = 30.28\text{cm}^4$
	$I_y = 6.75\text{cm}^4$
	$W_x = 6.16\text{cm}^3$
	$W_y = 2\text{cm}^3$

prof14



P-03-A405



	OUT	IN
 P	A-PH-1607	A-PH-3025
 S	A-PH-1607	A-SH-3025
	-	-
	-	-
	$I_x = 28\text{cm}^4$ $I_y = 8.58\text{cm}^4$ $W_x = 6.51\text{cm}^3$ $W_y = 2.59\text{cm}^3$	



profielen - profils - profiles



P-03-A514

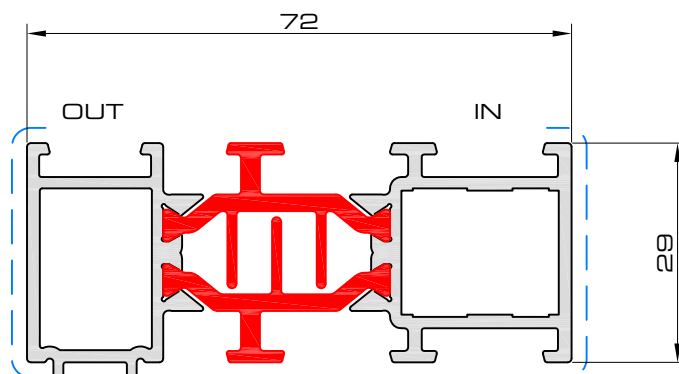

	$I_x = 24.82\text{cm}^4$
	$I_y = 3.27\text{cm}^4$
	$W_x = 6.82\text{cm}^3$
	$W_y = 2.03\text{cm}^3$

P-03-A515

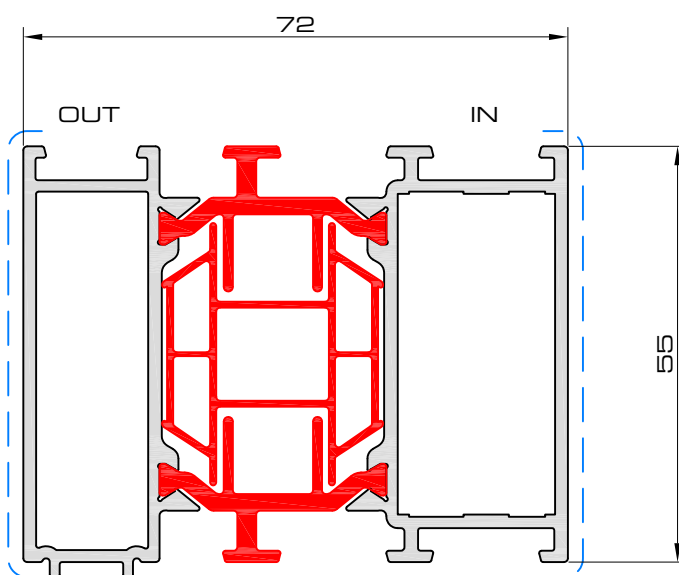

	$I_x = 38.25\text{cm}^4$
	$I_y = 19.24\text{cm}^4$
	$W_x = 10.55\text{cm}^3$
	$W_y = 6.6\text{cm}^3$

prof25



P-03-A516

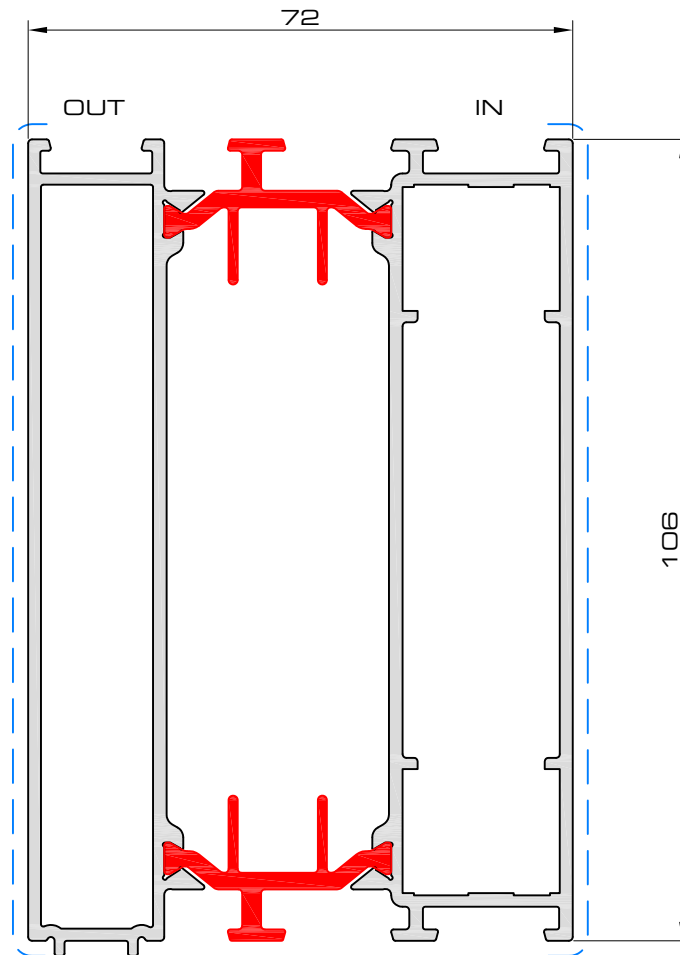

	$I_x = 65.08\text{cm}^4$
	$I_y = 113.84\text{cm}^4$
	$W_x = 17.87\text{cm}^3$
	$W_y = 20.82\text{cm}^3$

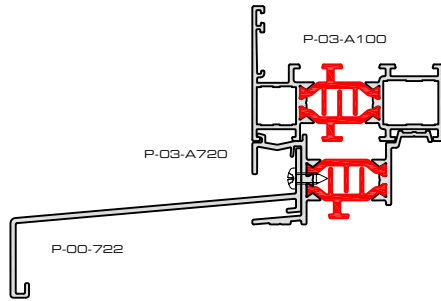
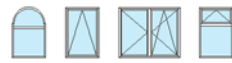

P-03-A720

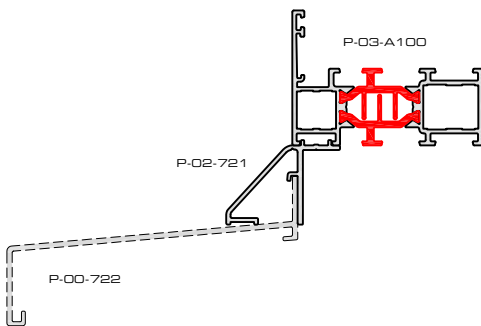
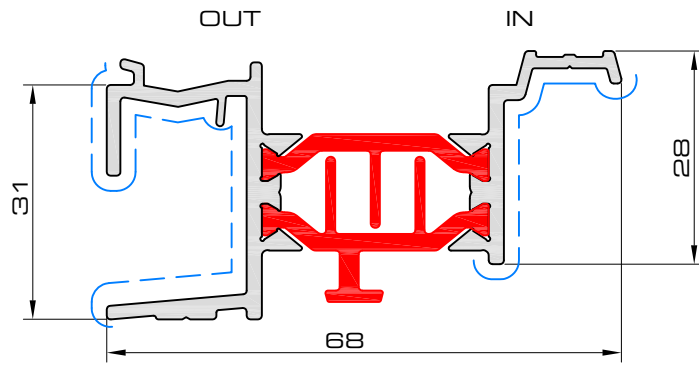

P-02-721

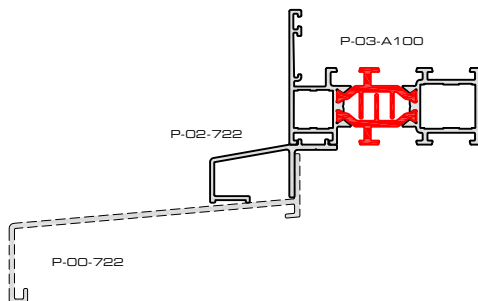
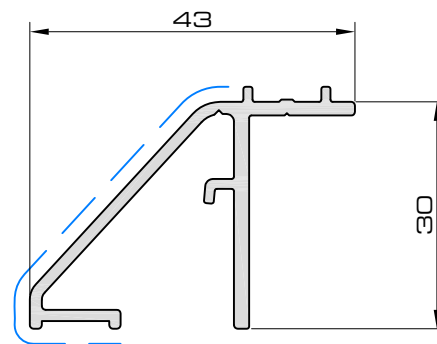

P-02-722

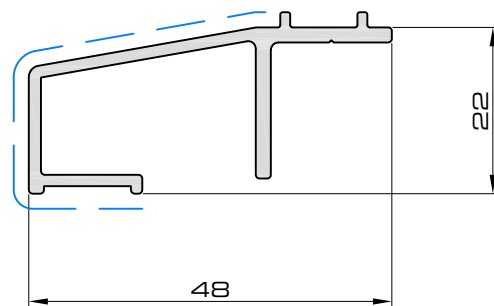

prof23



profielen - profils - profiles

P-03-723

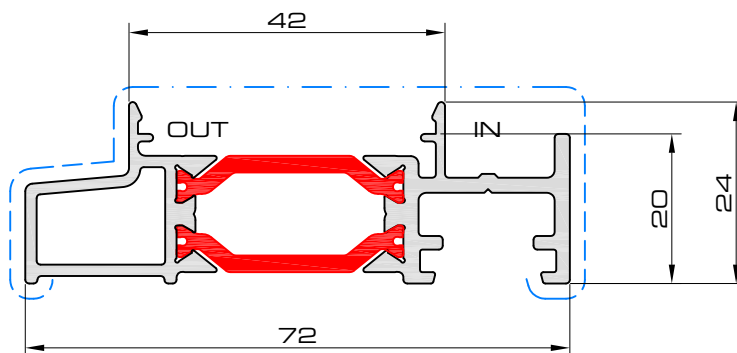

P-03-724

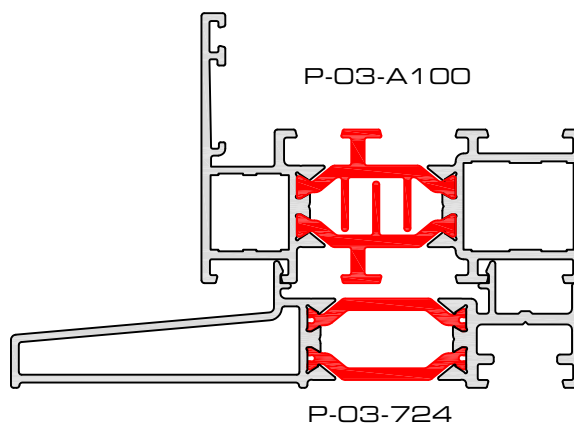
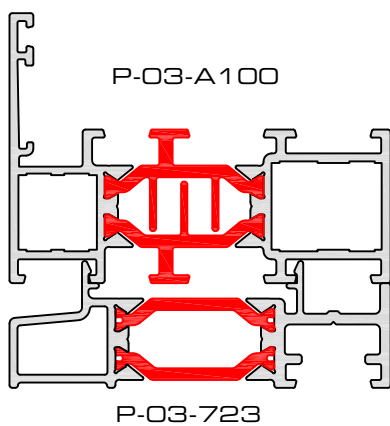
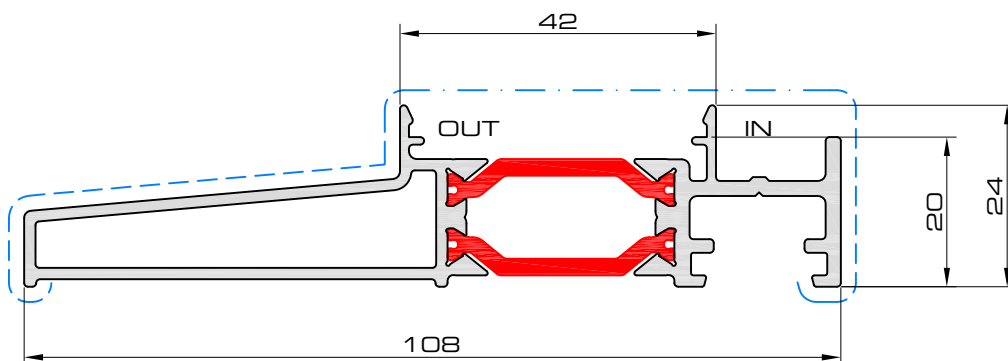

prof39

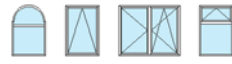

P-03-725

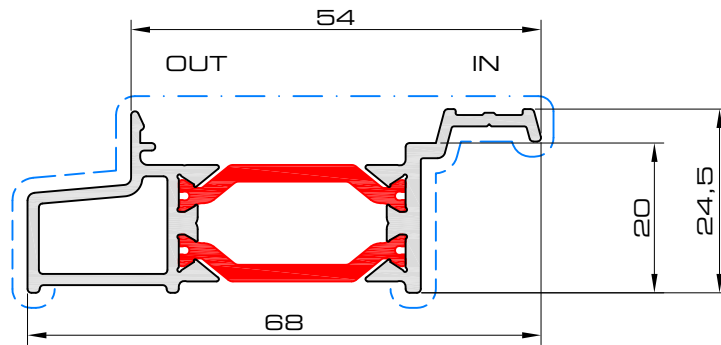

P-03-726

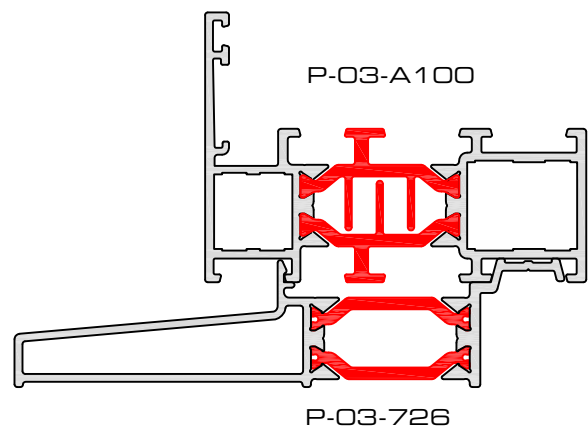
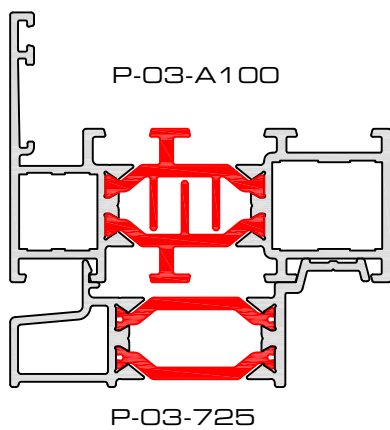
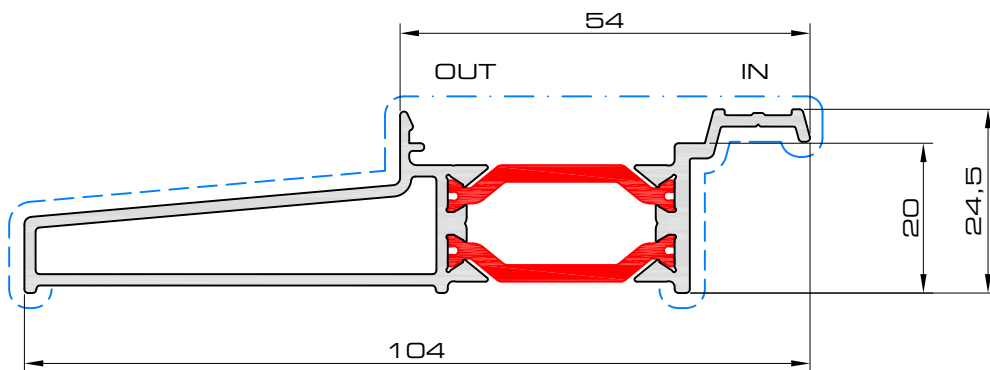

prof40



profielen - profils - profiles

P-03-727

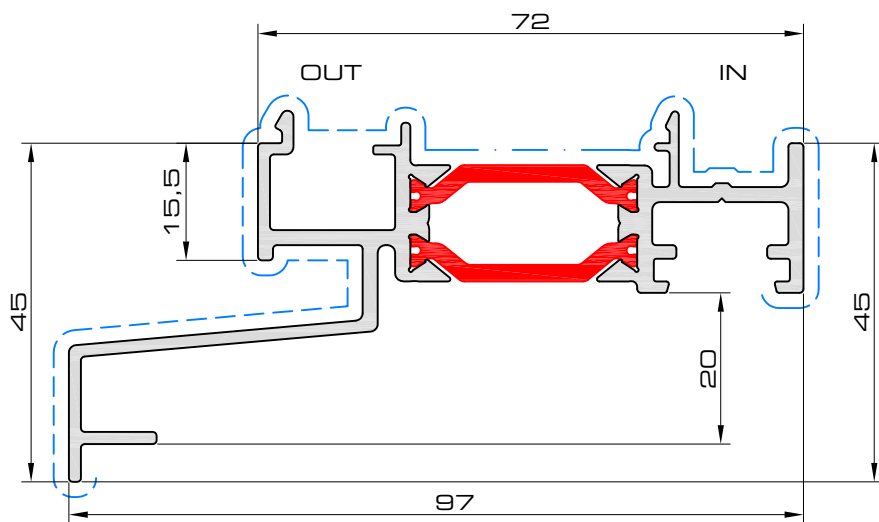

	$I_x = 39.84\text{cm}^4$
	$I_y = 5.09\text{cm}^4$
	$W_x = 8.02\text{cm}^3$
	$W_y = 1.7\text{cm}^3$

P-03-728

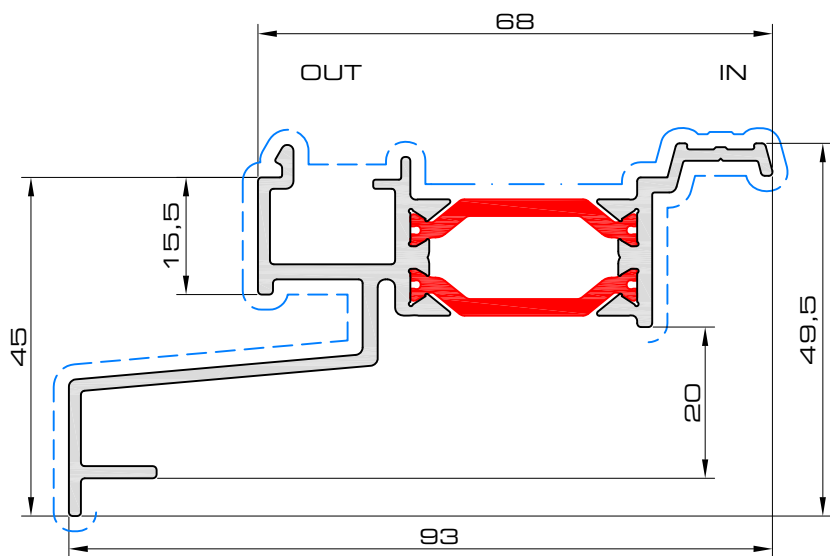

	$I_x = 25.35\text{cm}^4$
	$I_y = 5.41\text{cm}^4$
	$W_x = 4.97\text{cm}^3$
	$W_y = 1.8\text{cm}^3$

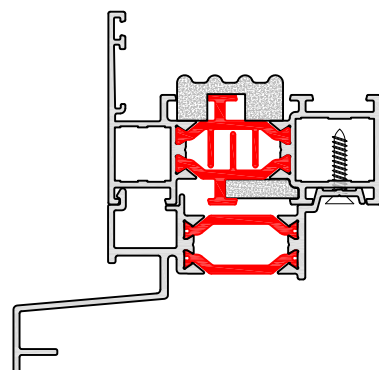
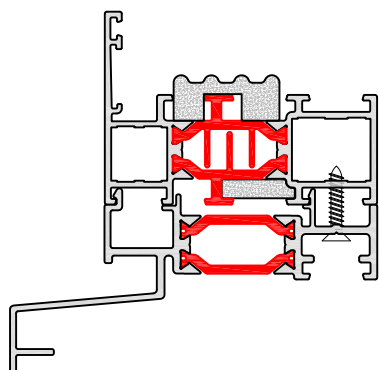

prof54



profielen - profils - profiles

P-00-100

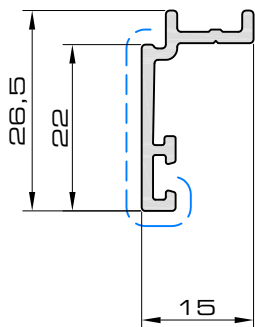

P-00-101

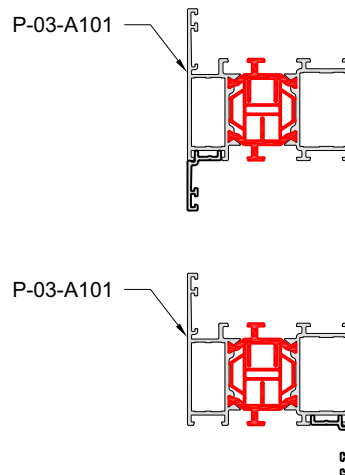
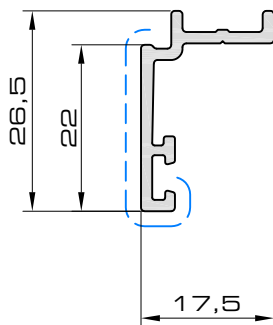

P-00-105

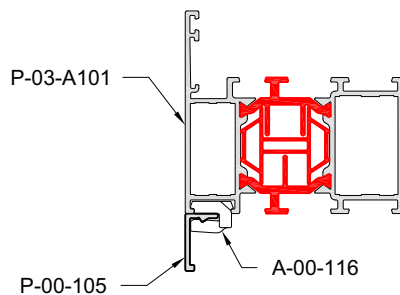
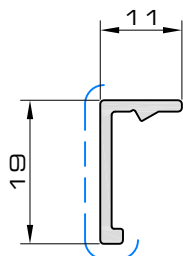

P-00-106

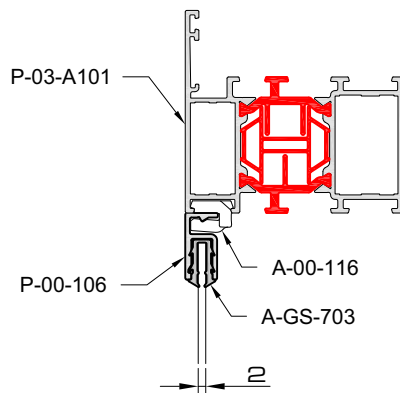
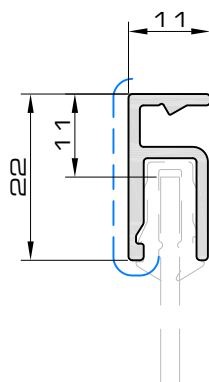

prof26



profielen - profils - profiles

P-00-300

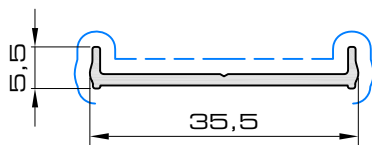

P-00-302

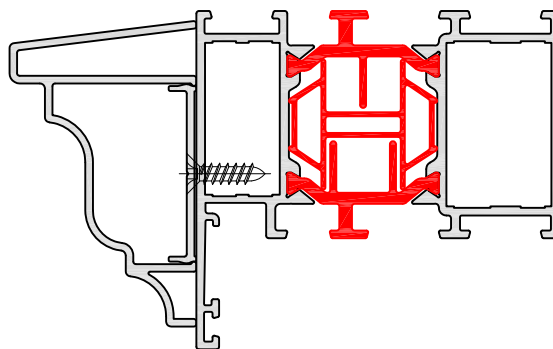
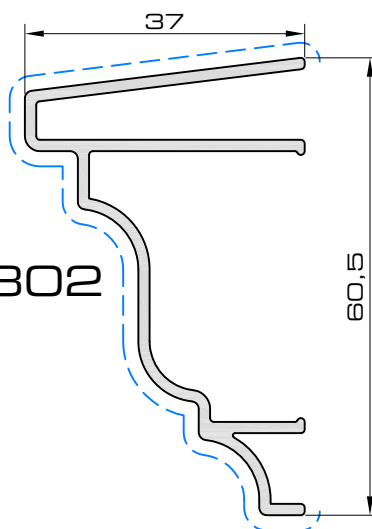

P-00-303

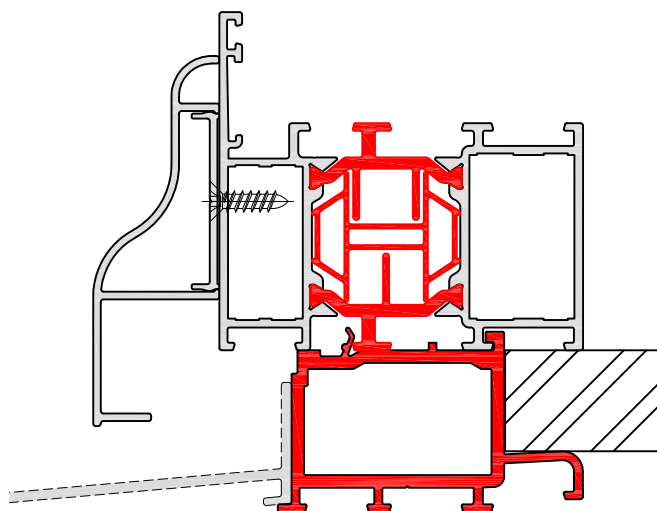
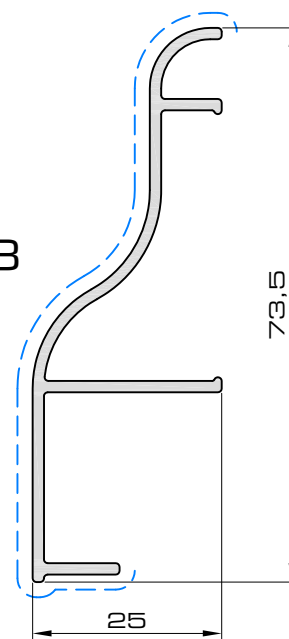

prof53



profielen - profils - profiles

Triton 03

P-00-515

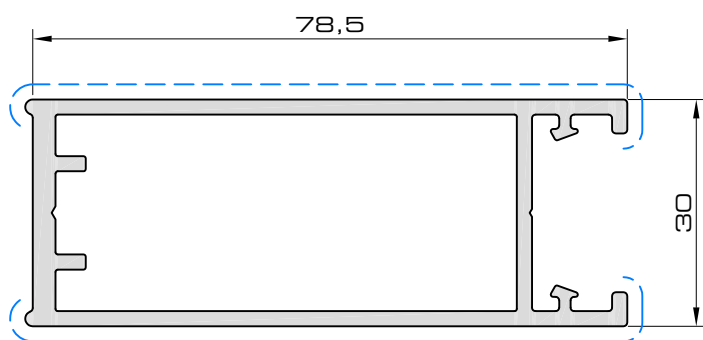

	$I_x = 35.37\text{cm}^4$
	$I_y = 7.34\text{cm}^4$
	$W_x = 8.35\text{cm}^3$
	$W_y = 4.89\text{cm}^3$

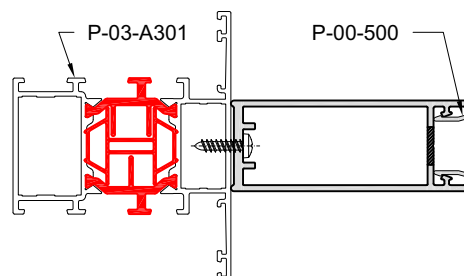

prof42



P-00-718

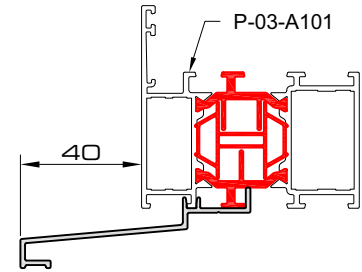
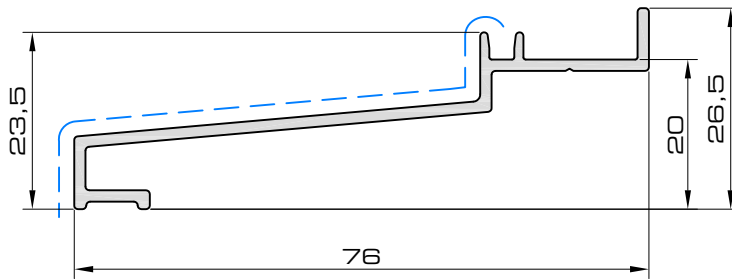

P-00-719

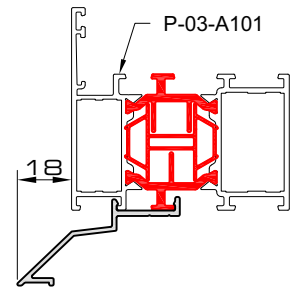
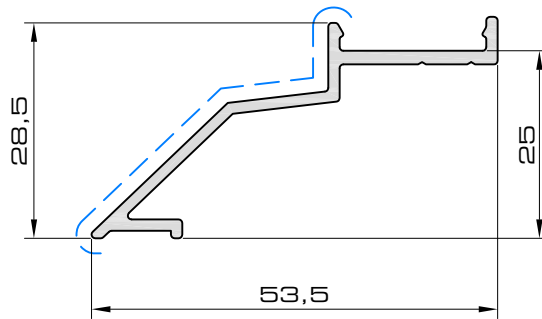

P-00-738

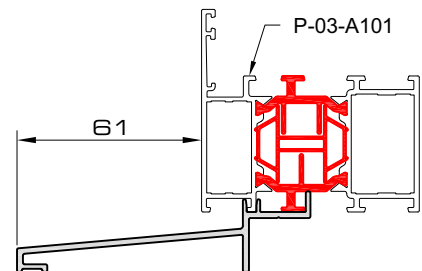
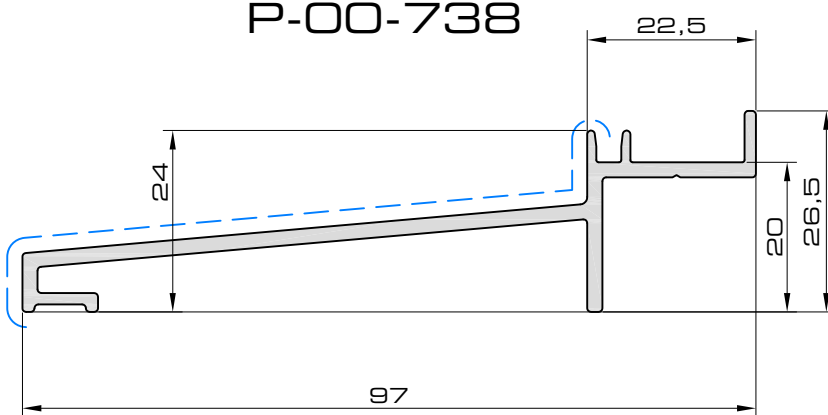

prof51



profielen - profils - profiles

Triton 03

P-00-720

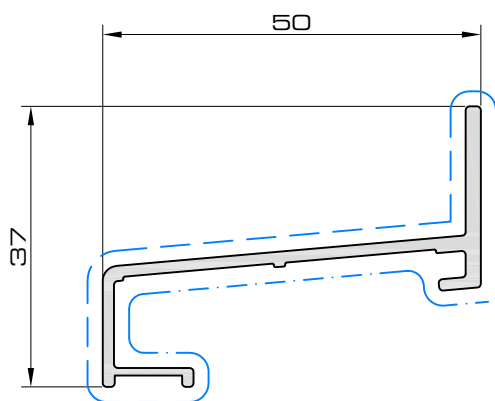

P-00-721

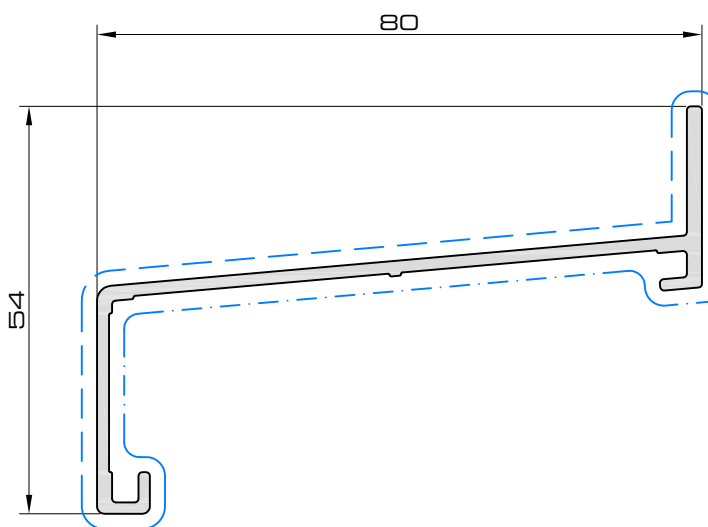

P-00-722

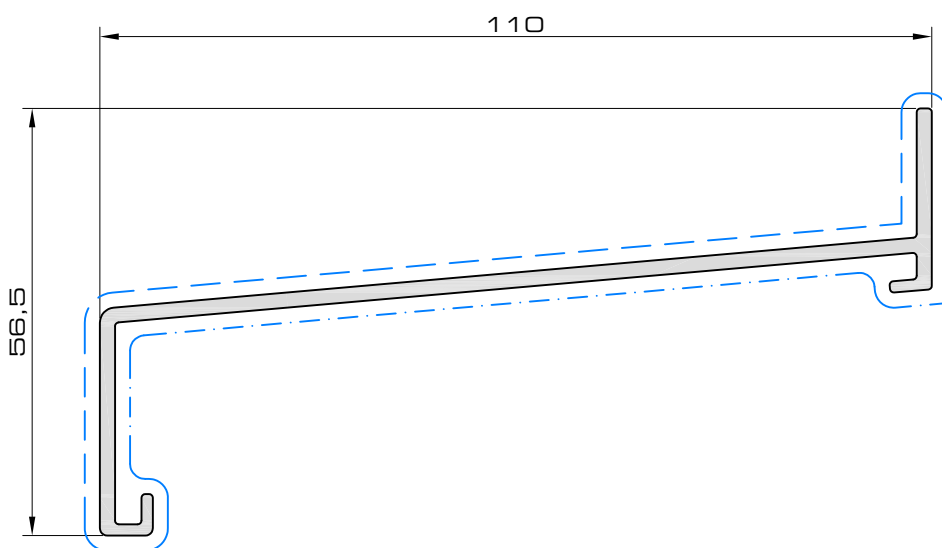

prof8

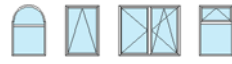

P-00-723

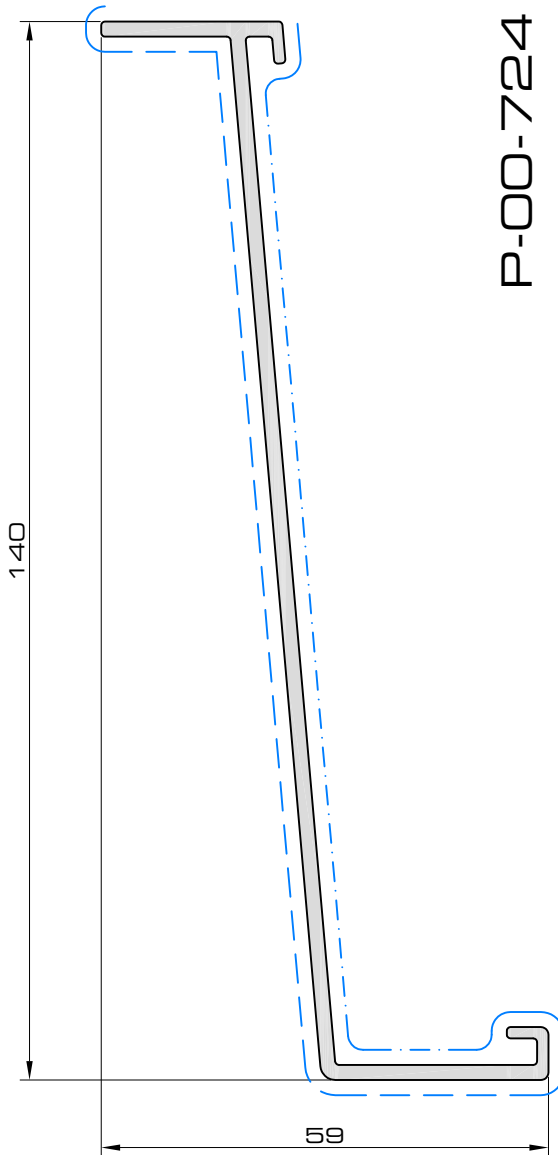

P-00-724

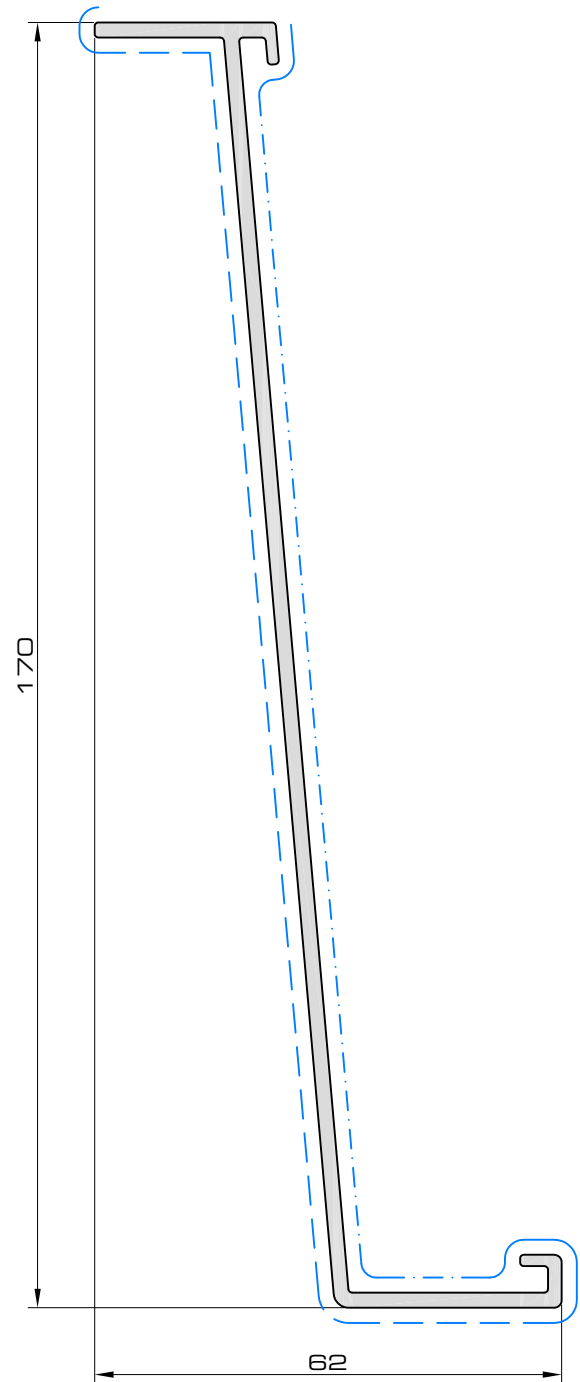

prof9



profielen - profils - profiles

Triton 03

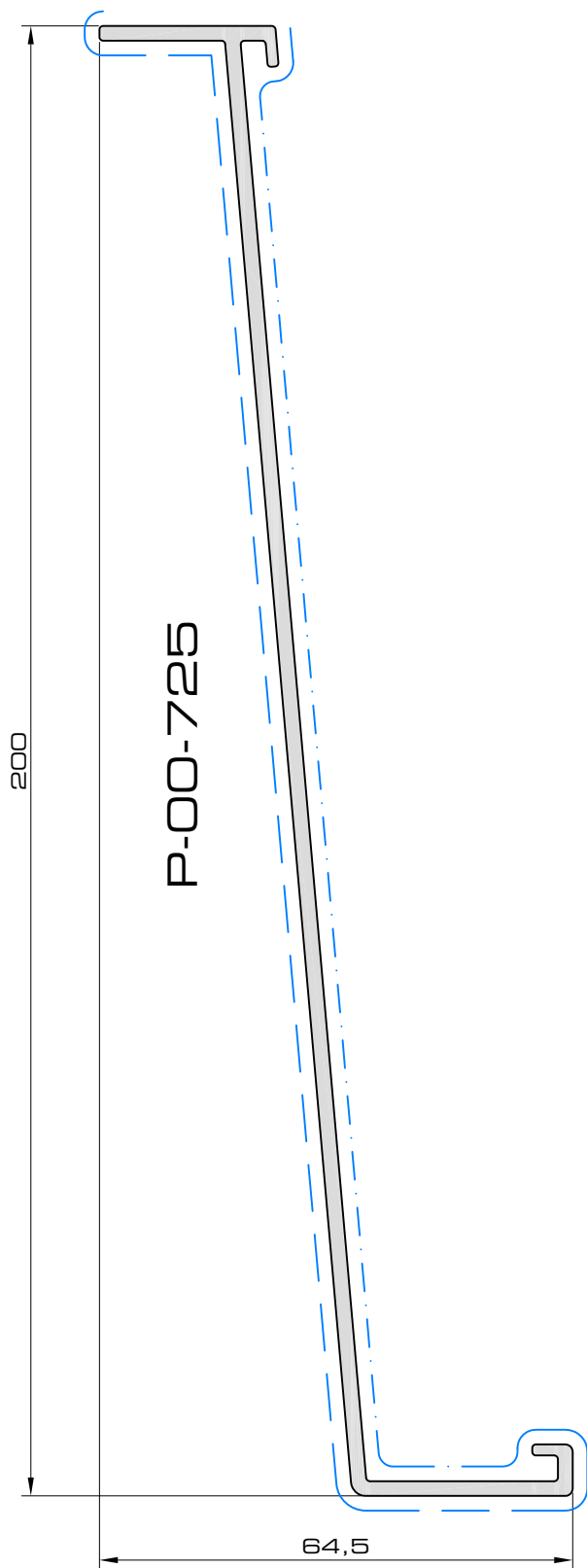

prof10

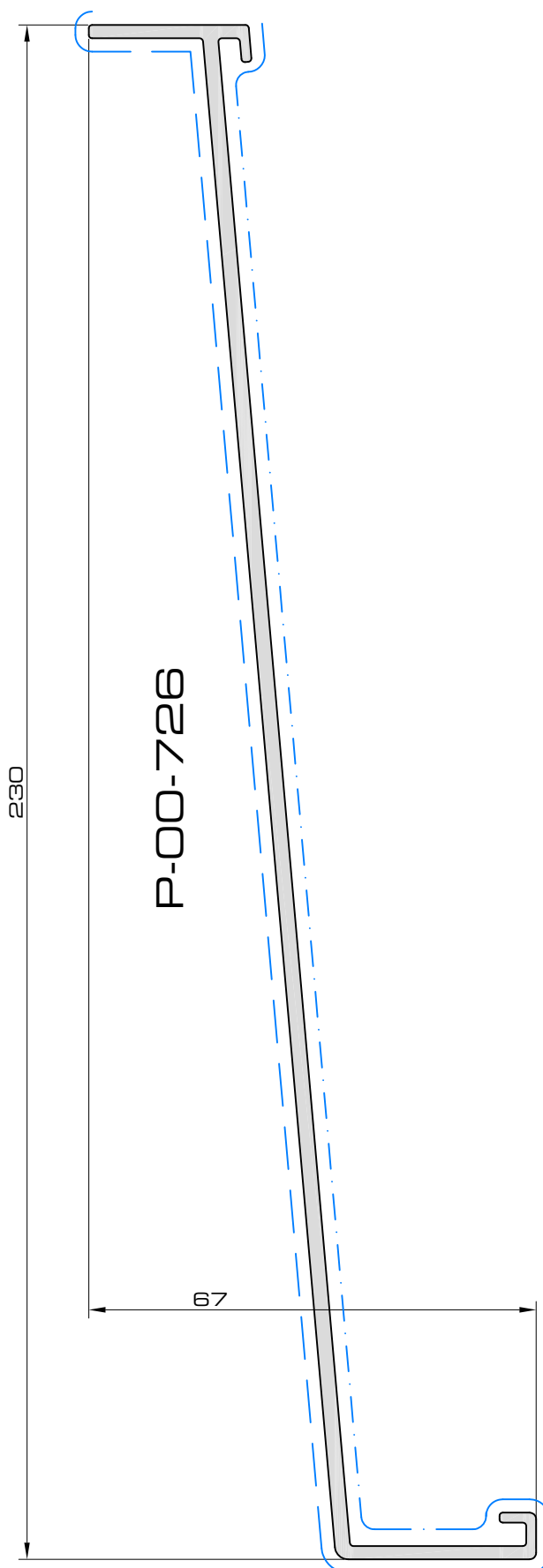



profielen - profils - profiles

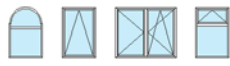

P-6s-003

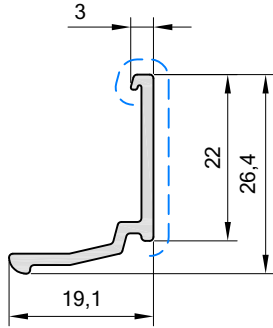

P-6s-007

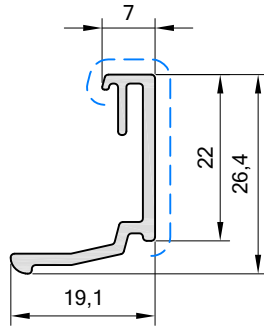

P-6s-011

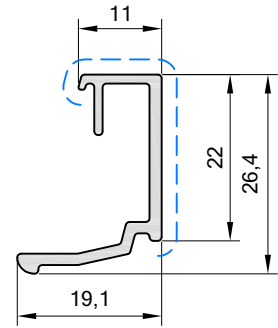

P-6s-013

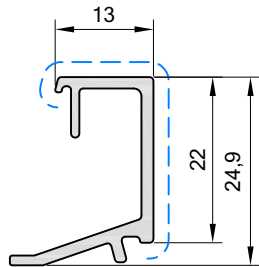

P-6s-015

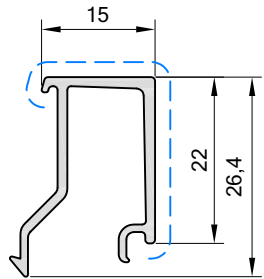

P-6s-019

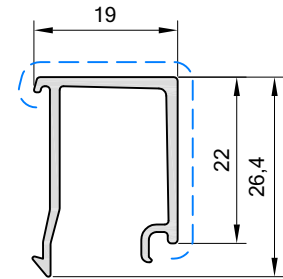

P-6s-021

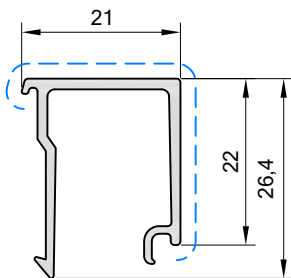

P-6s-023

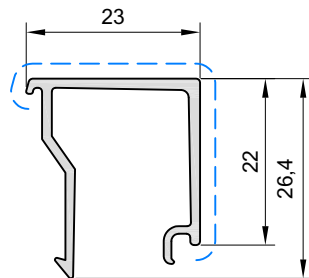

P-6s-025

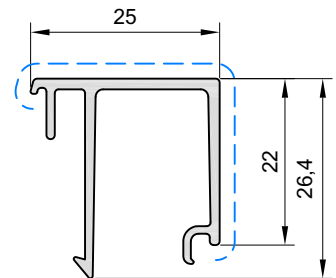

P-6s-027

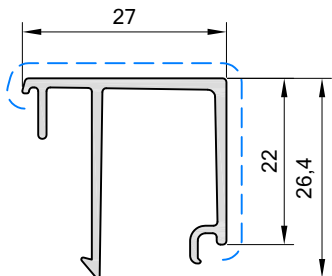

P-6s-029

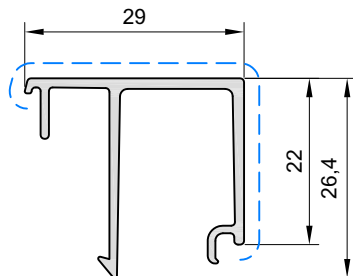

P-6s-031

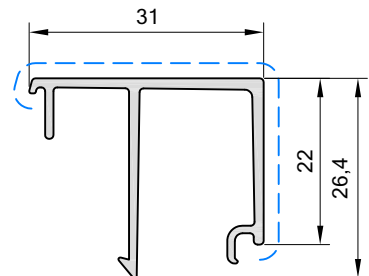



P-6s-033

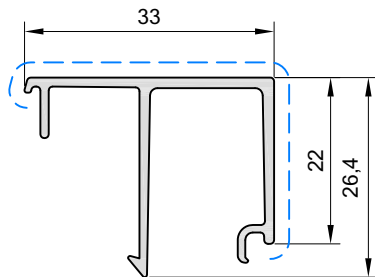

P-6s-035

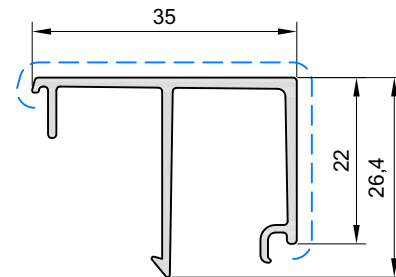

P-6s-037

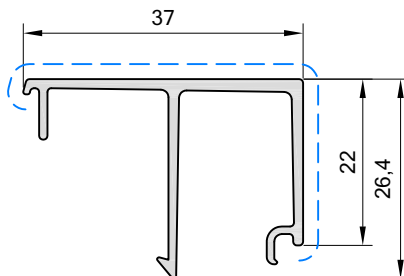

P-6s-039

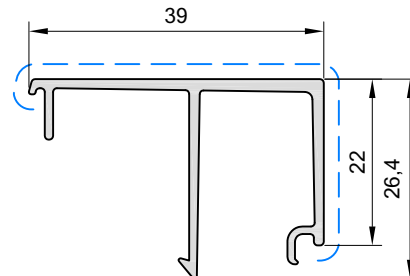

P-6s-041

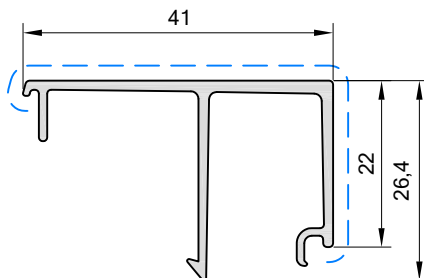

P-6s-043

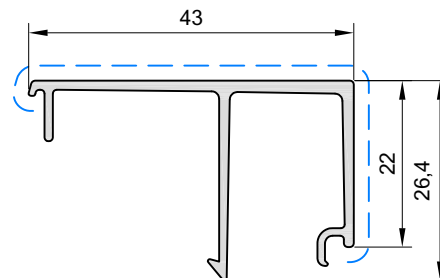

P-6s-045

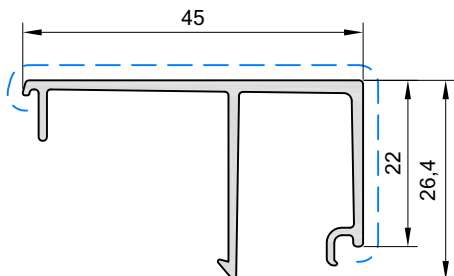

P-6s-048

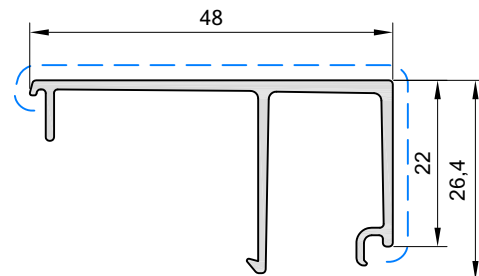



profielen - profils - profiles

Triton 03

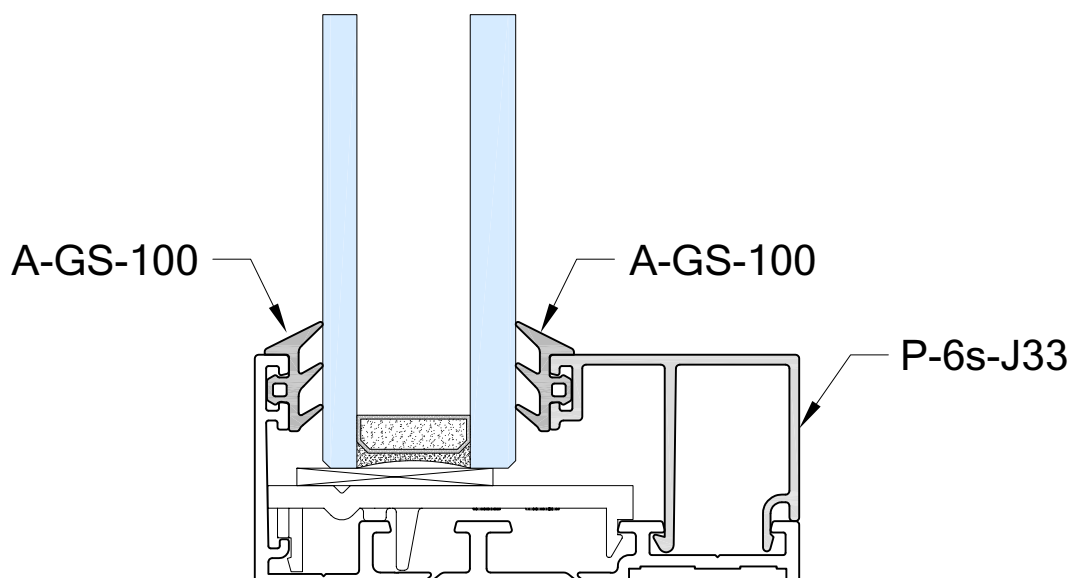
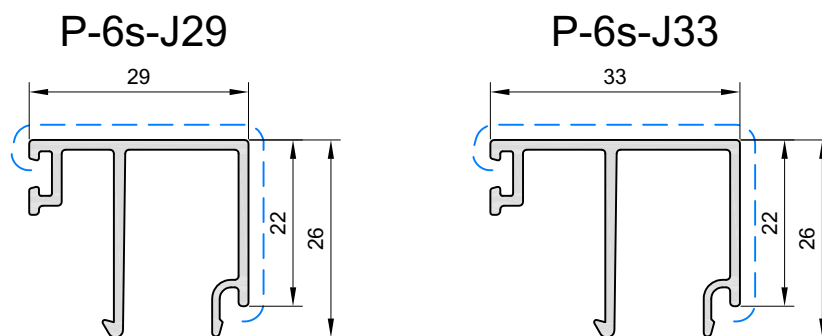

prof1b

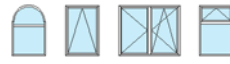

P-6b-015

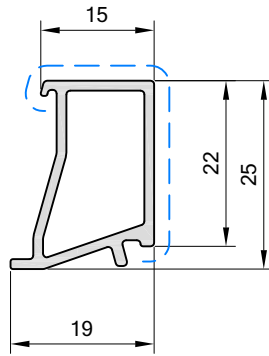

P-6b-019

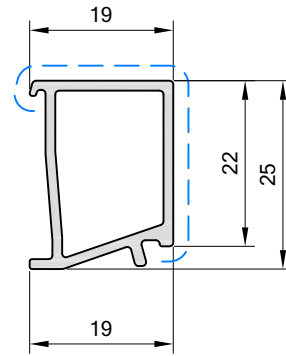

P-6b-021

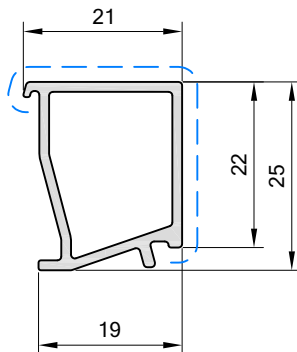

P-6b-023

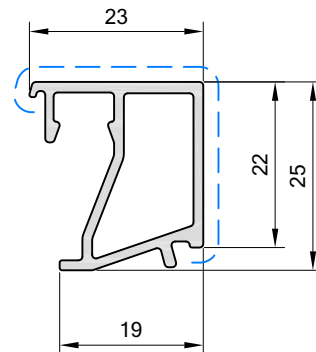

P-6b-025

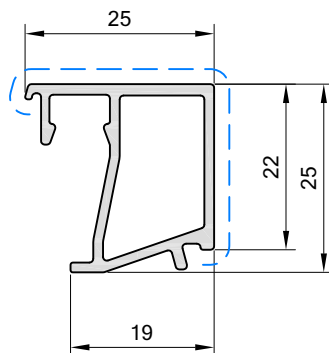

P-6b-027

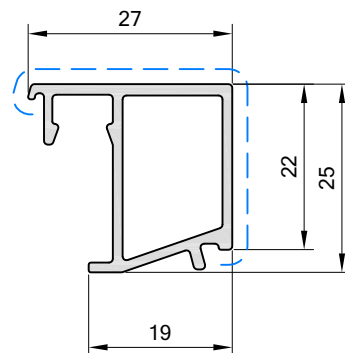

prof2



profielen - profils - profiles

Triton 03

P-6b-029

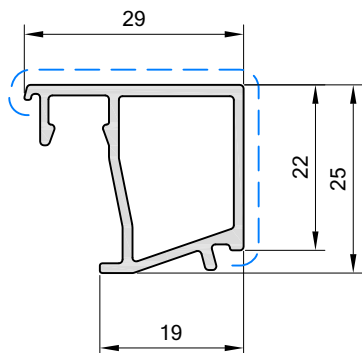

P-6b-031

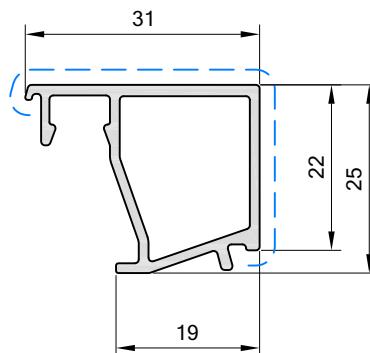

P-6b-033

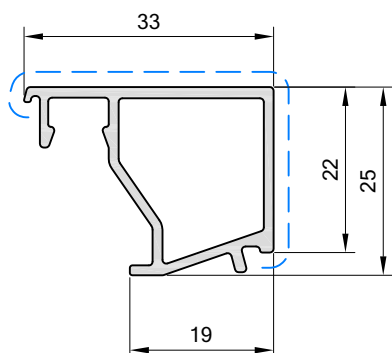

P-6b-035

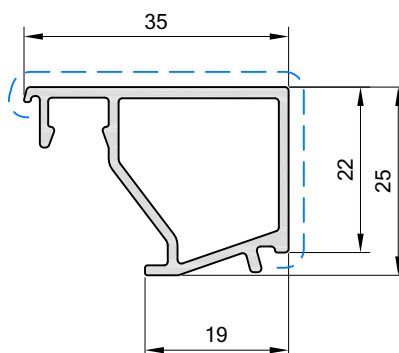

P-6b-037

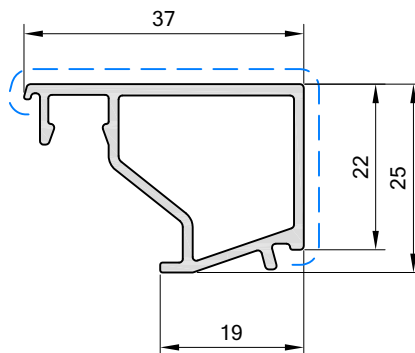

prof2

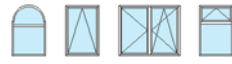

P-6b-039

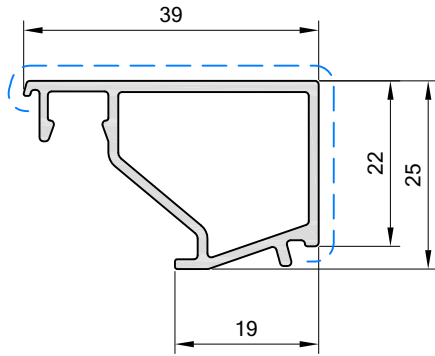

P-6b-042

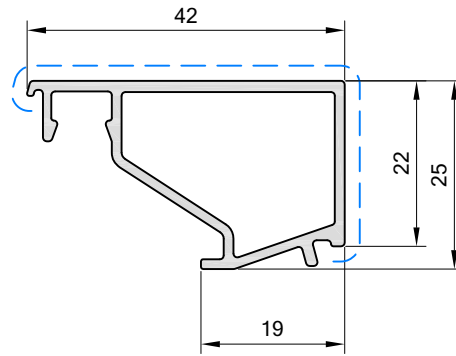

P-6b-043

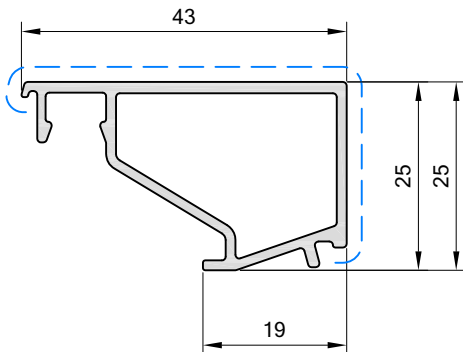

P-6b-045

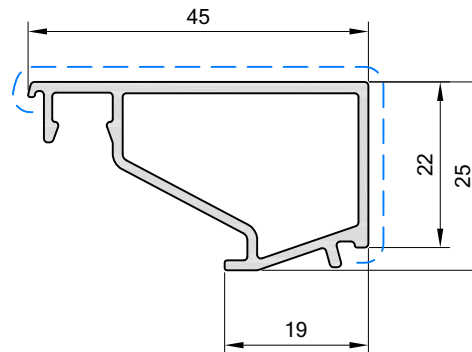

P-6b-048

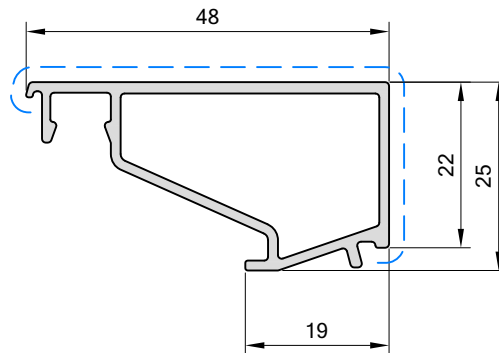

prof2

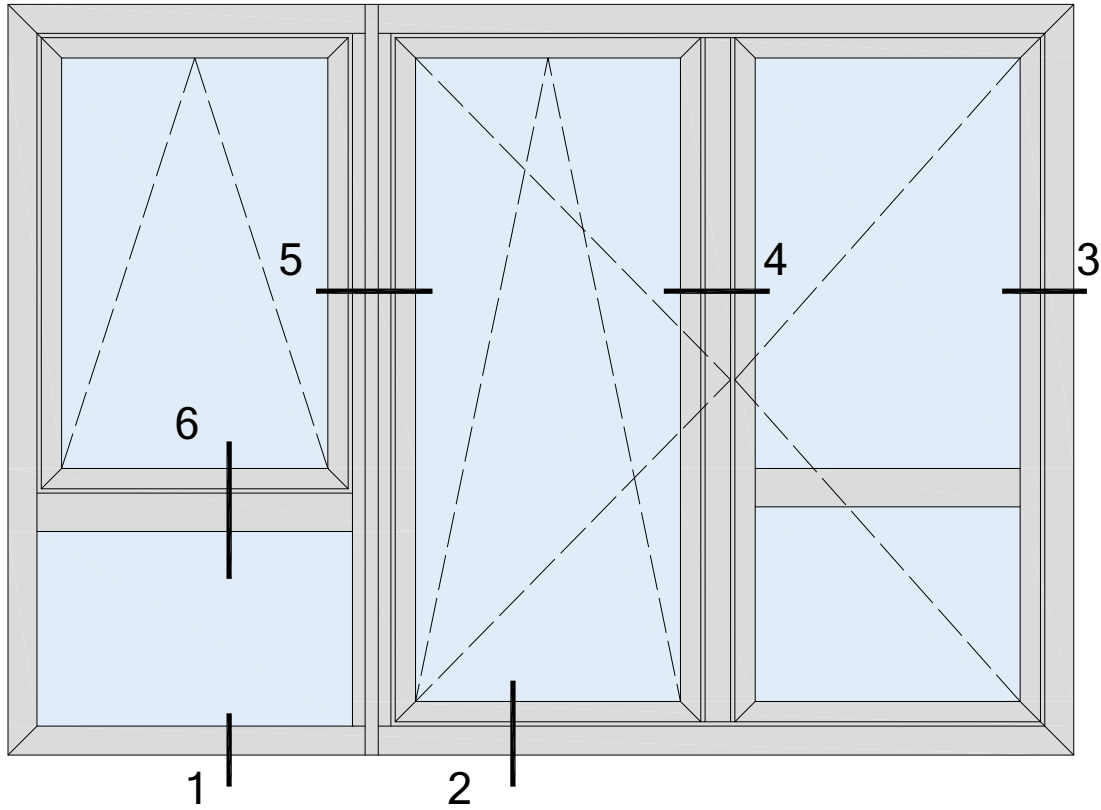
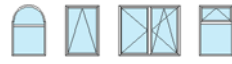

1a

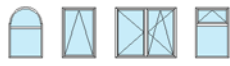

Triton 03

doorsneden - coupes - sections

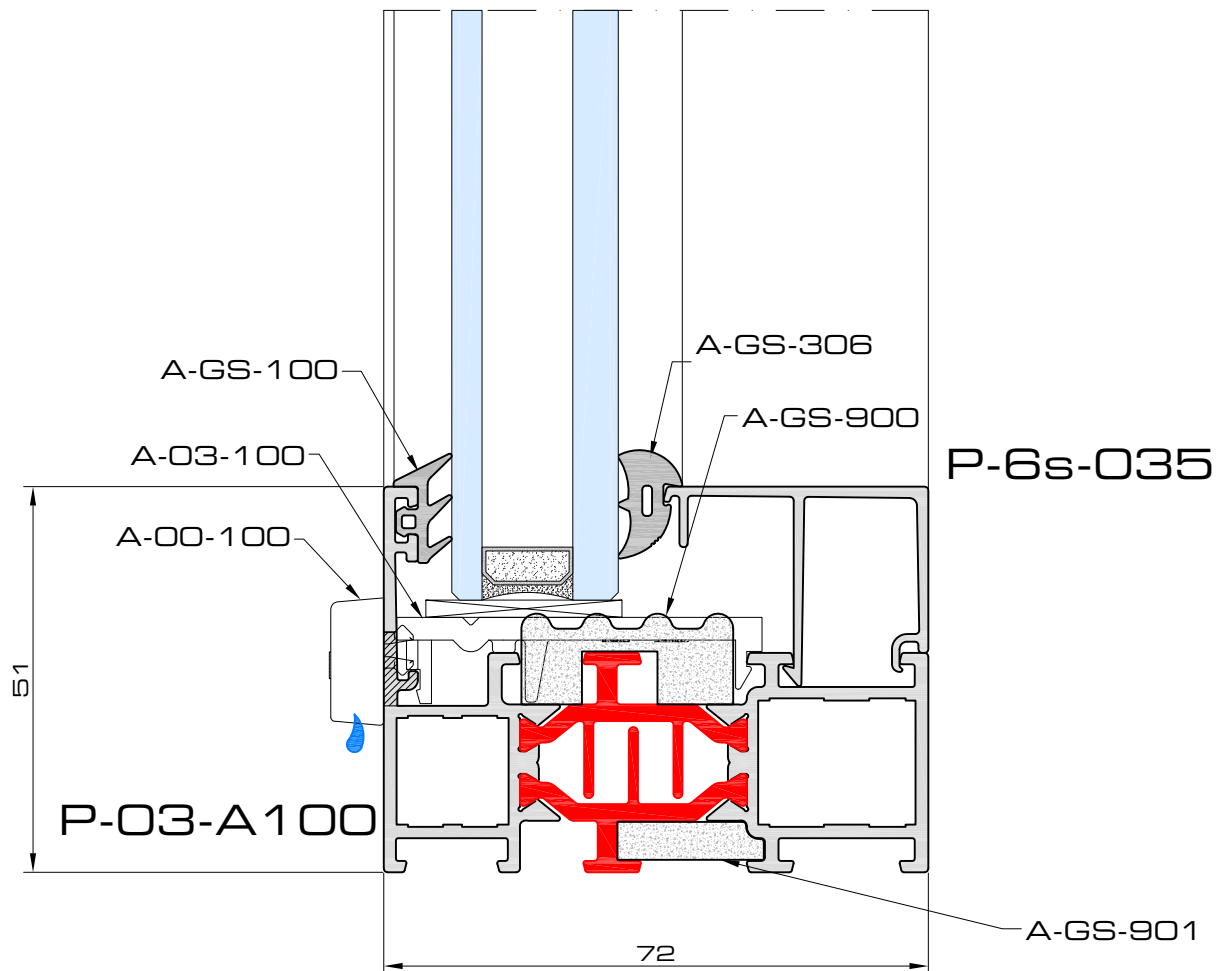
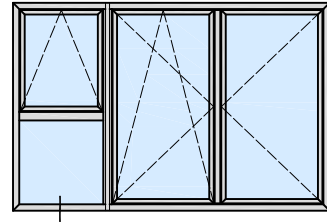

a door1a

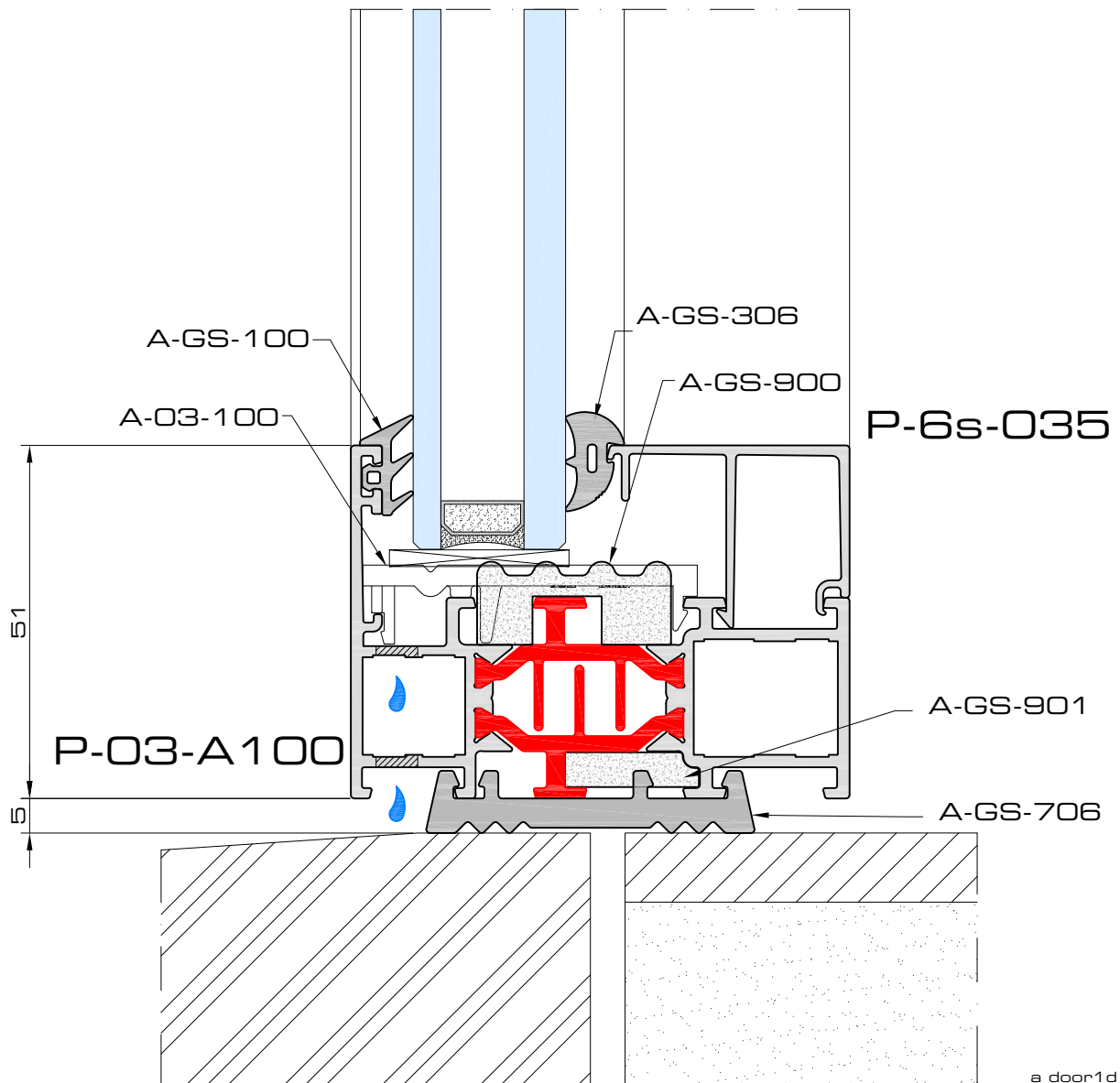
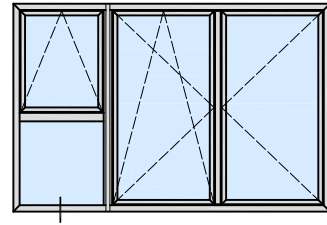
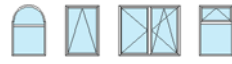

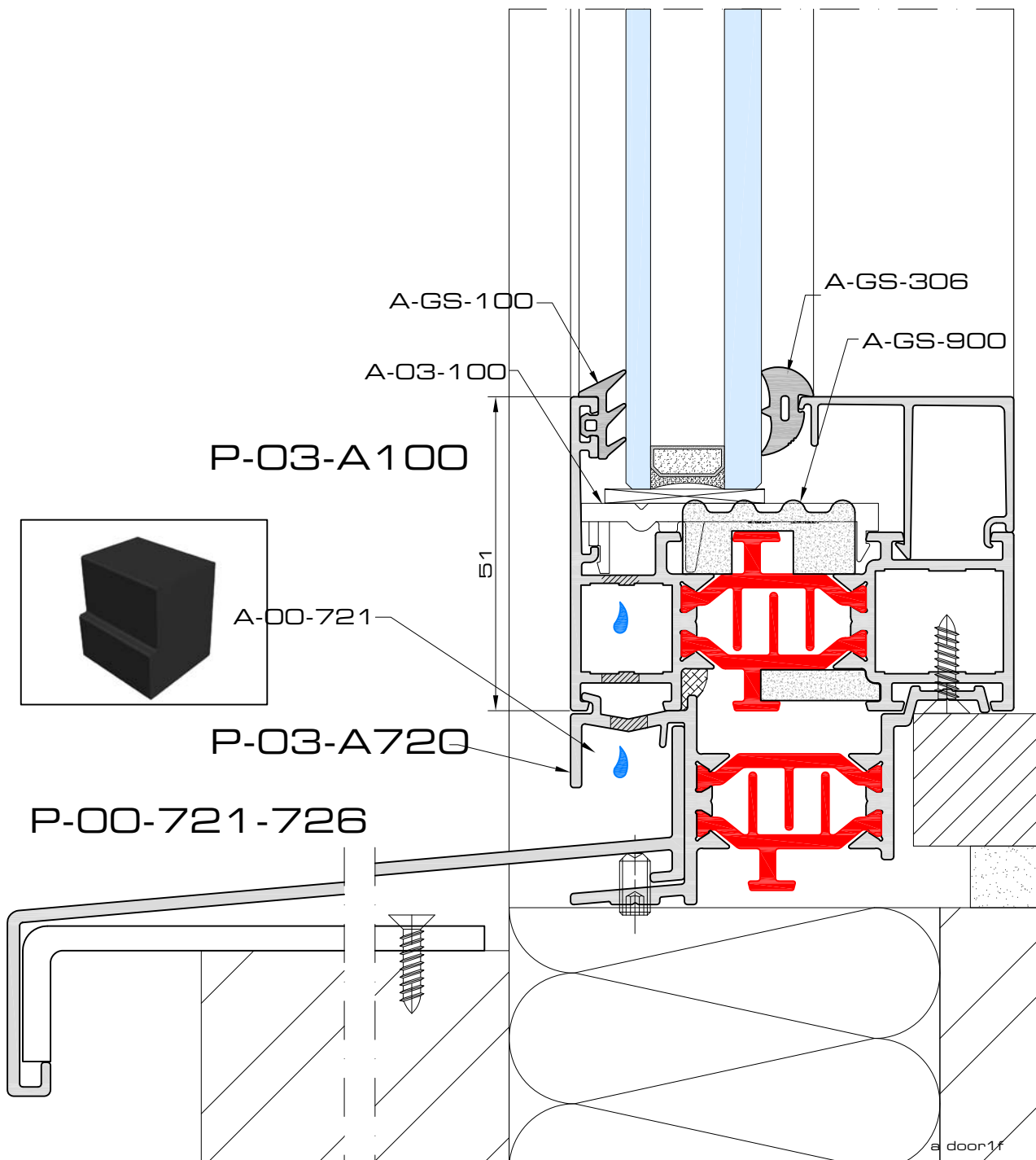
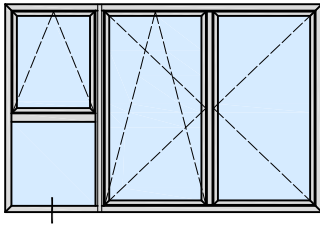
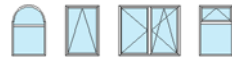

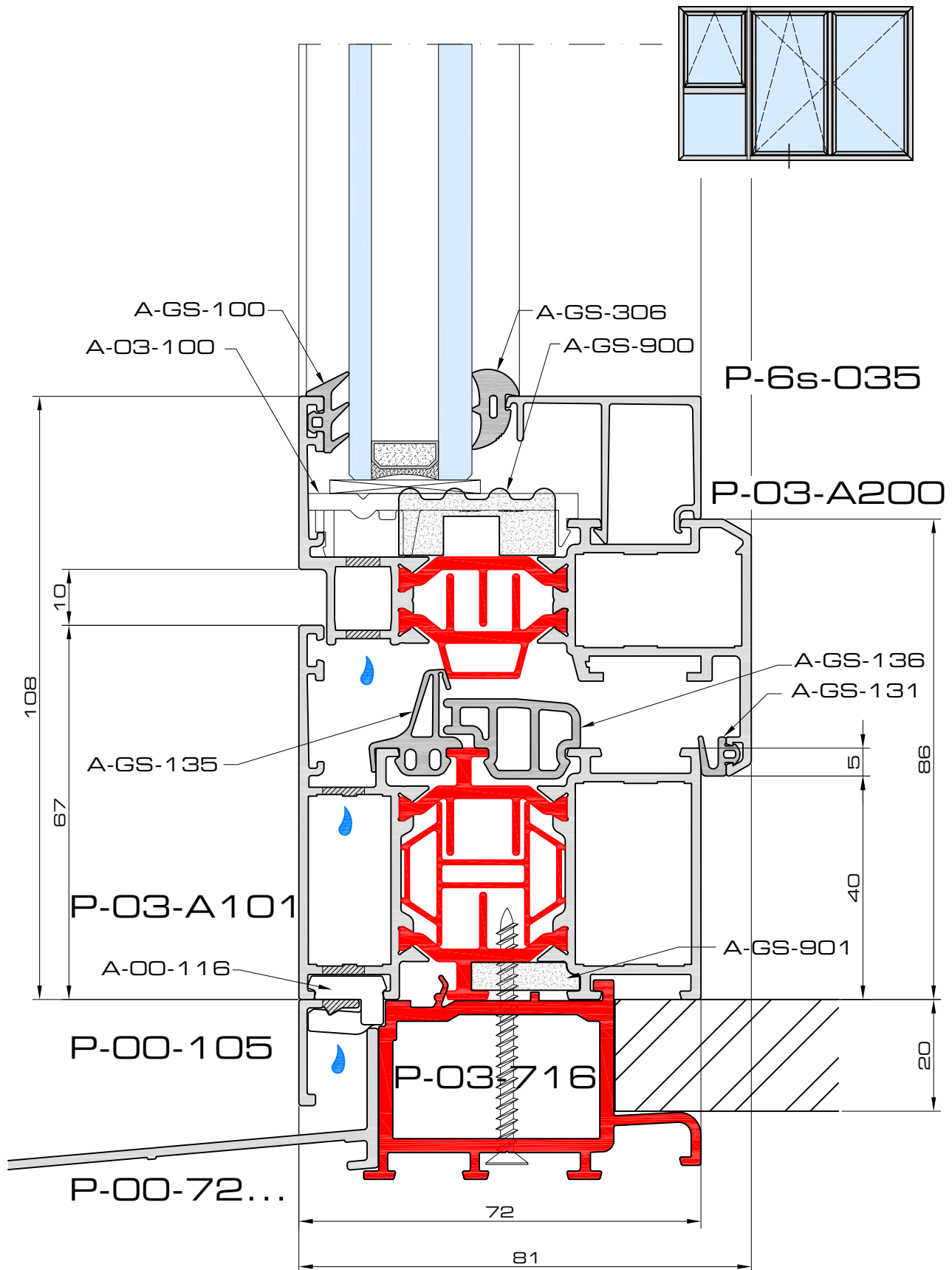
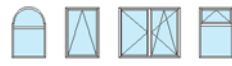

a_door2a

2b

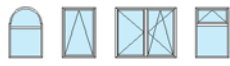

Triton 03

doorsneden - coupes - sections

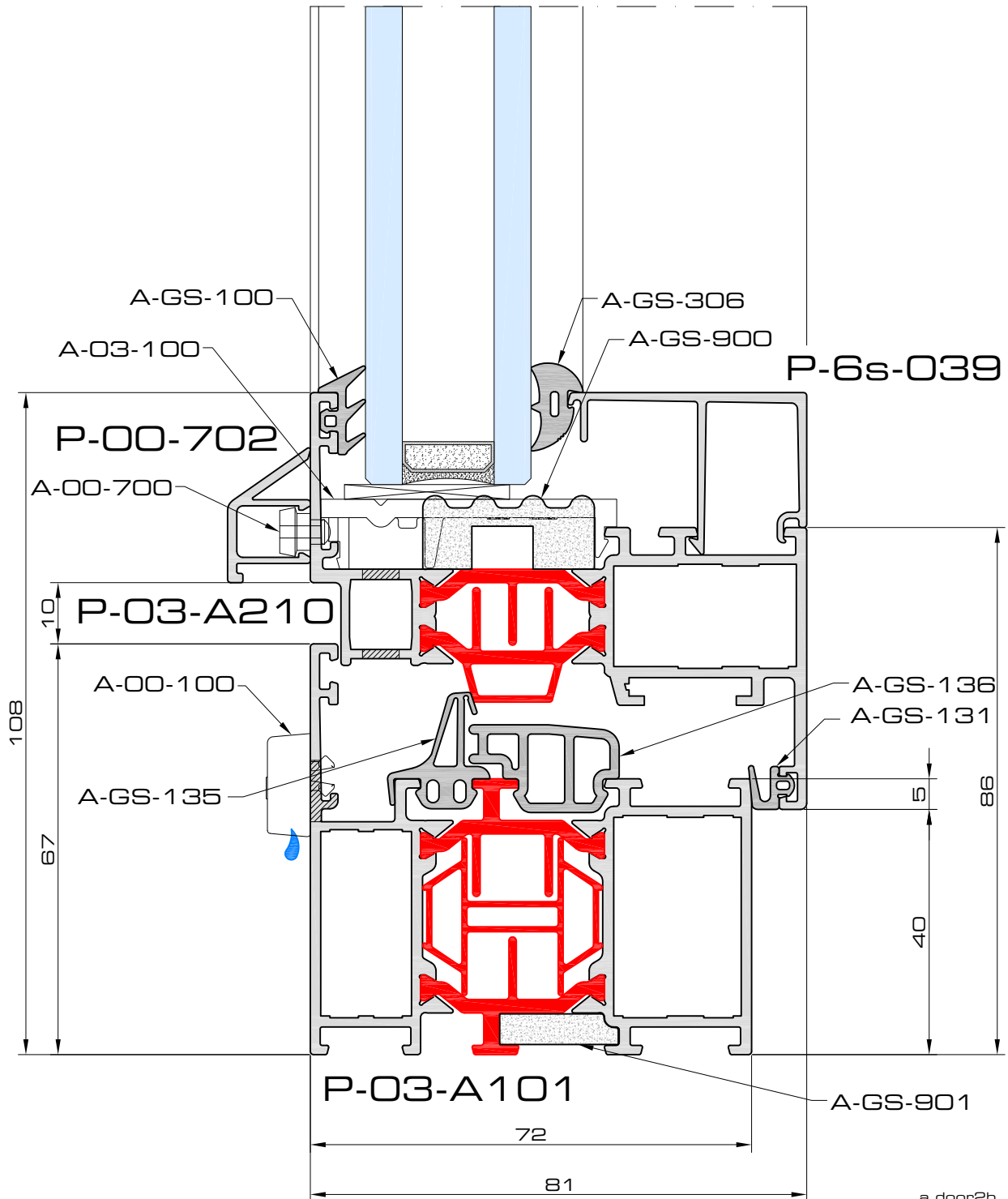
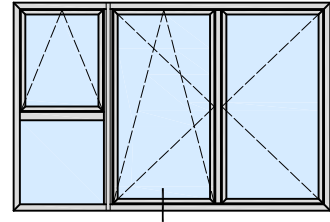

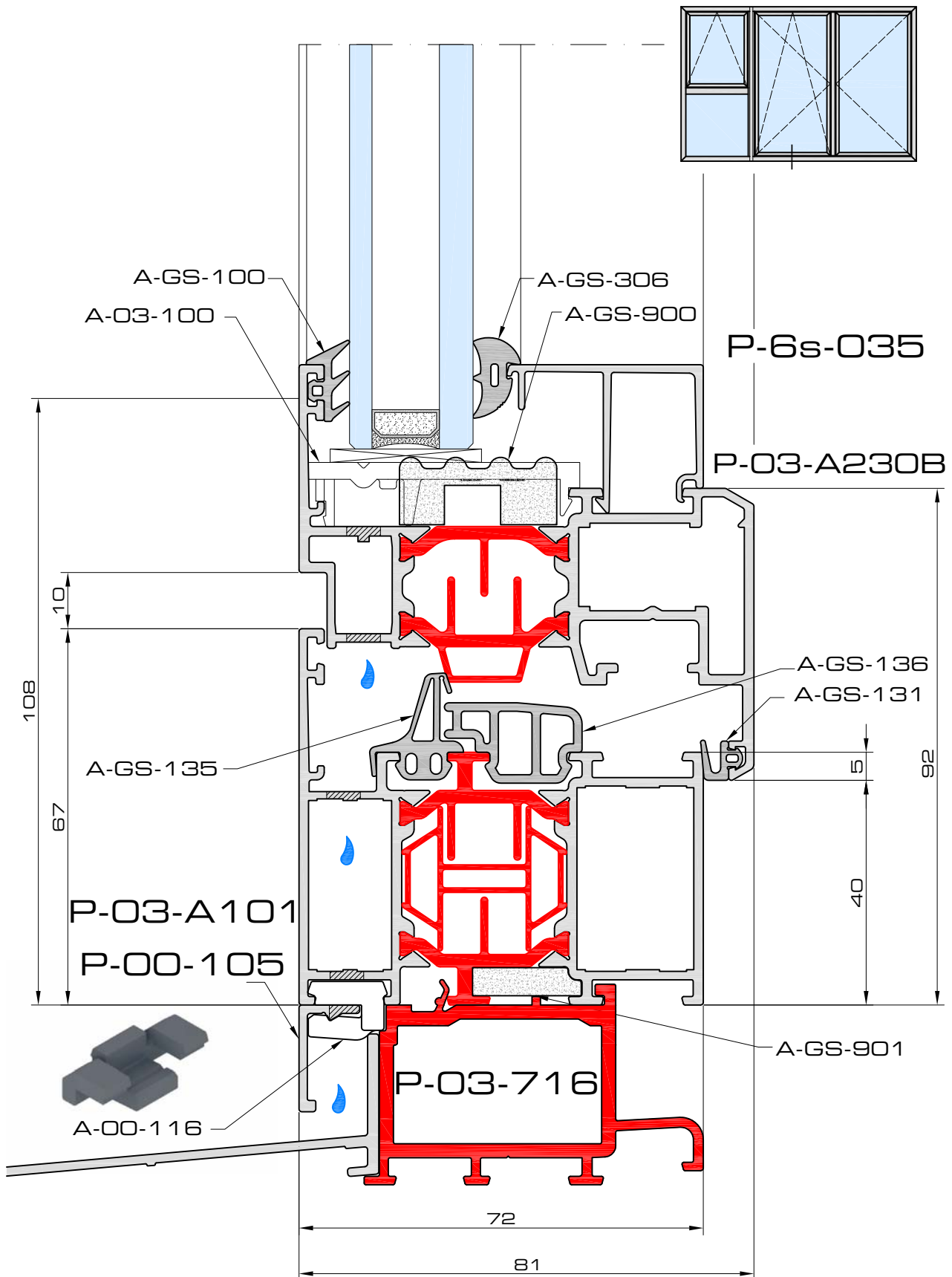
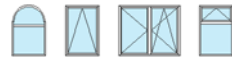

a_door2d

3b

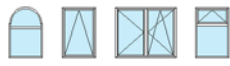

Triton 03

doorsneden - coupes - sections

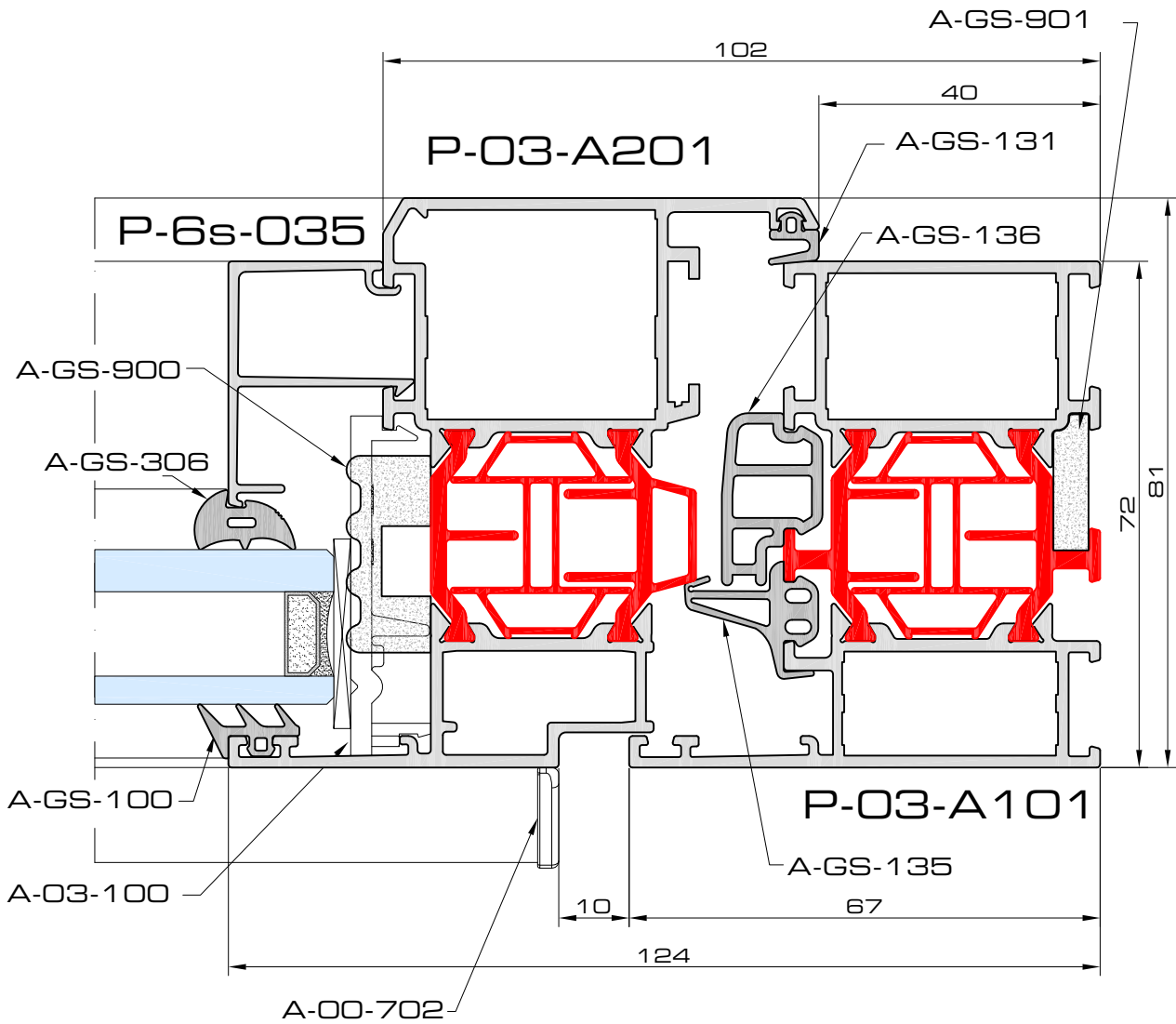
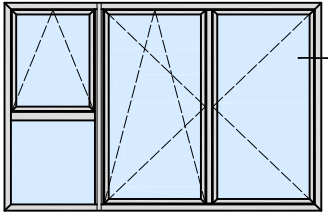

a door3b

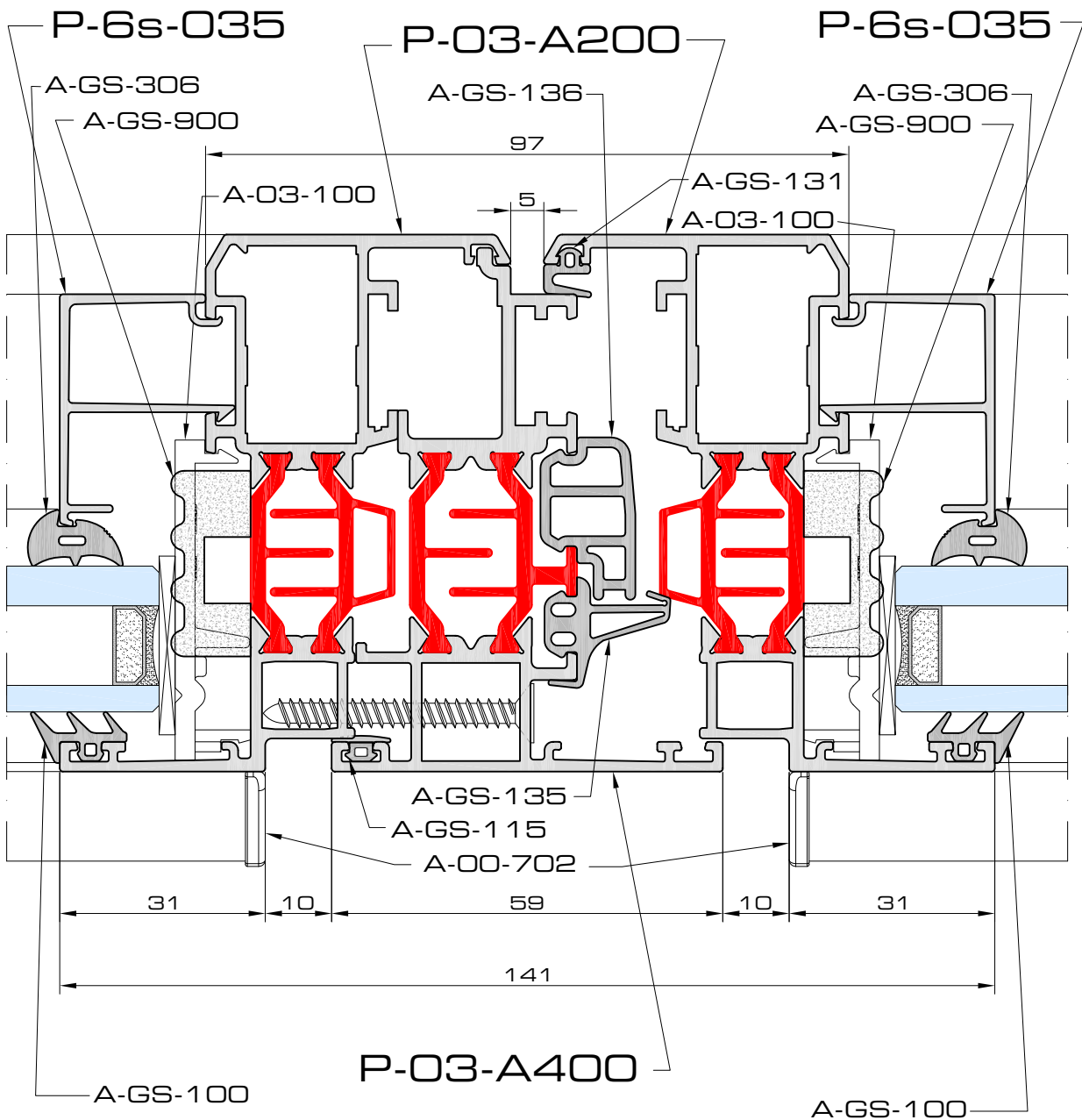
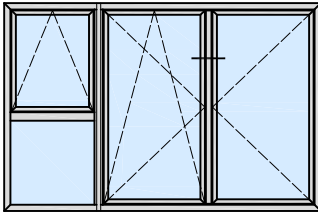
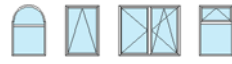

a door4

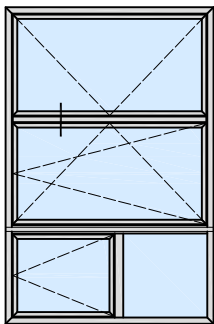
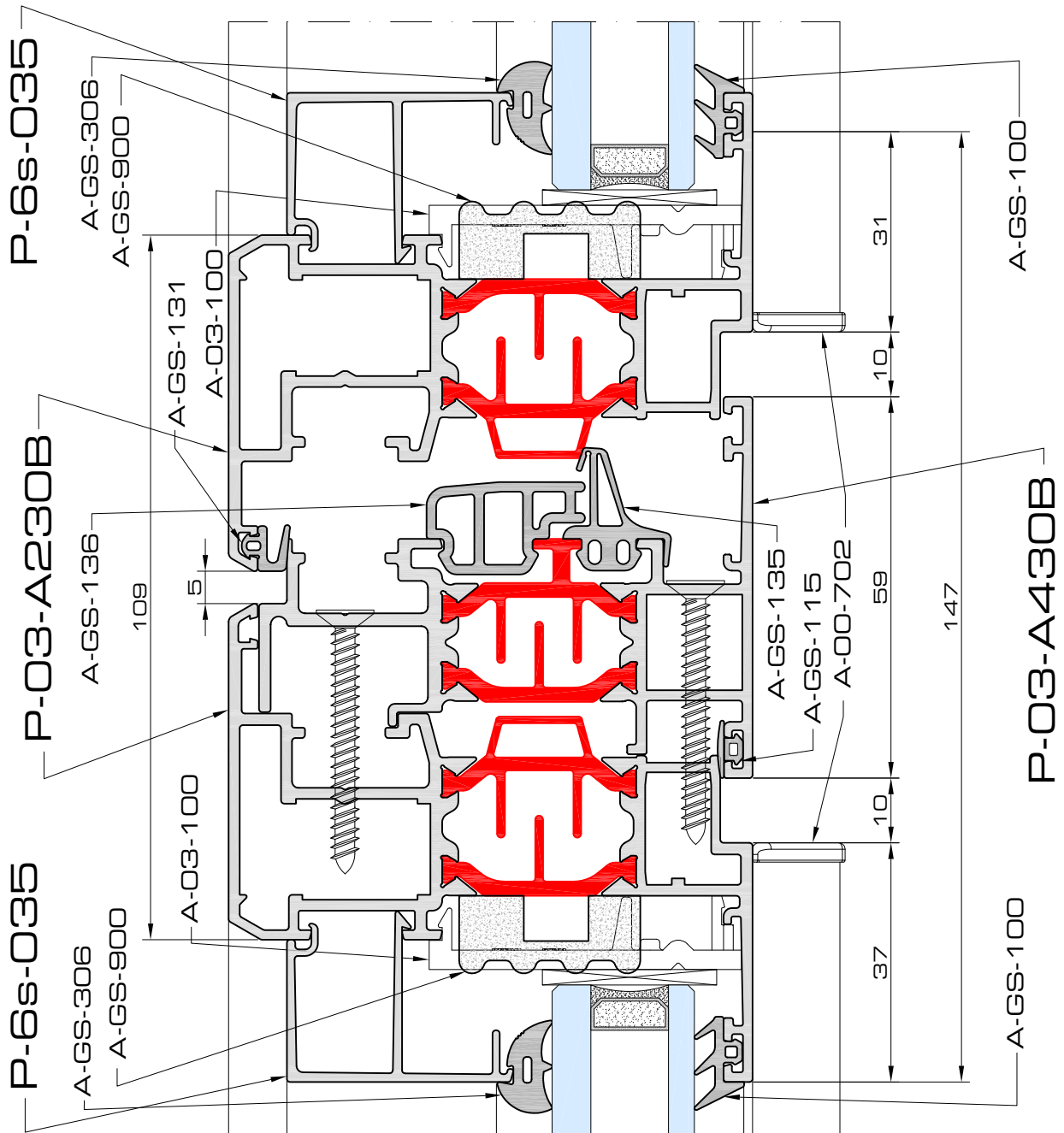
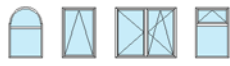

a door4b

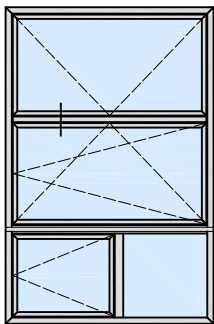
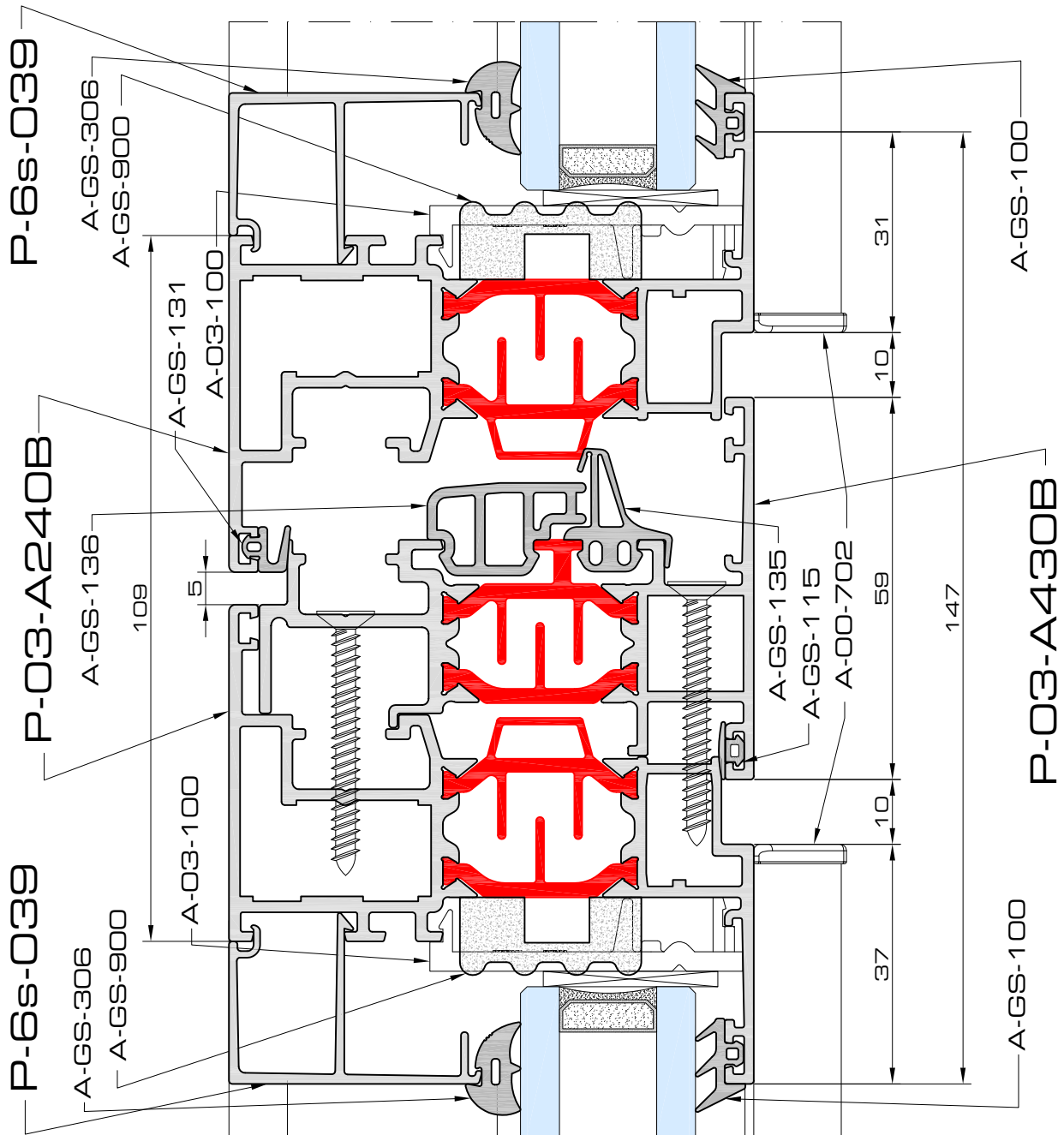
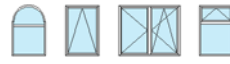

a door4c

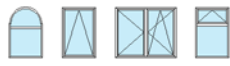

doorsneden - coupes - sections

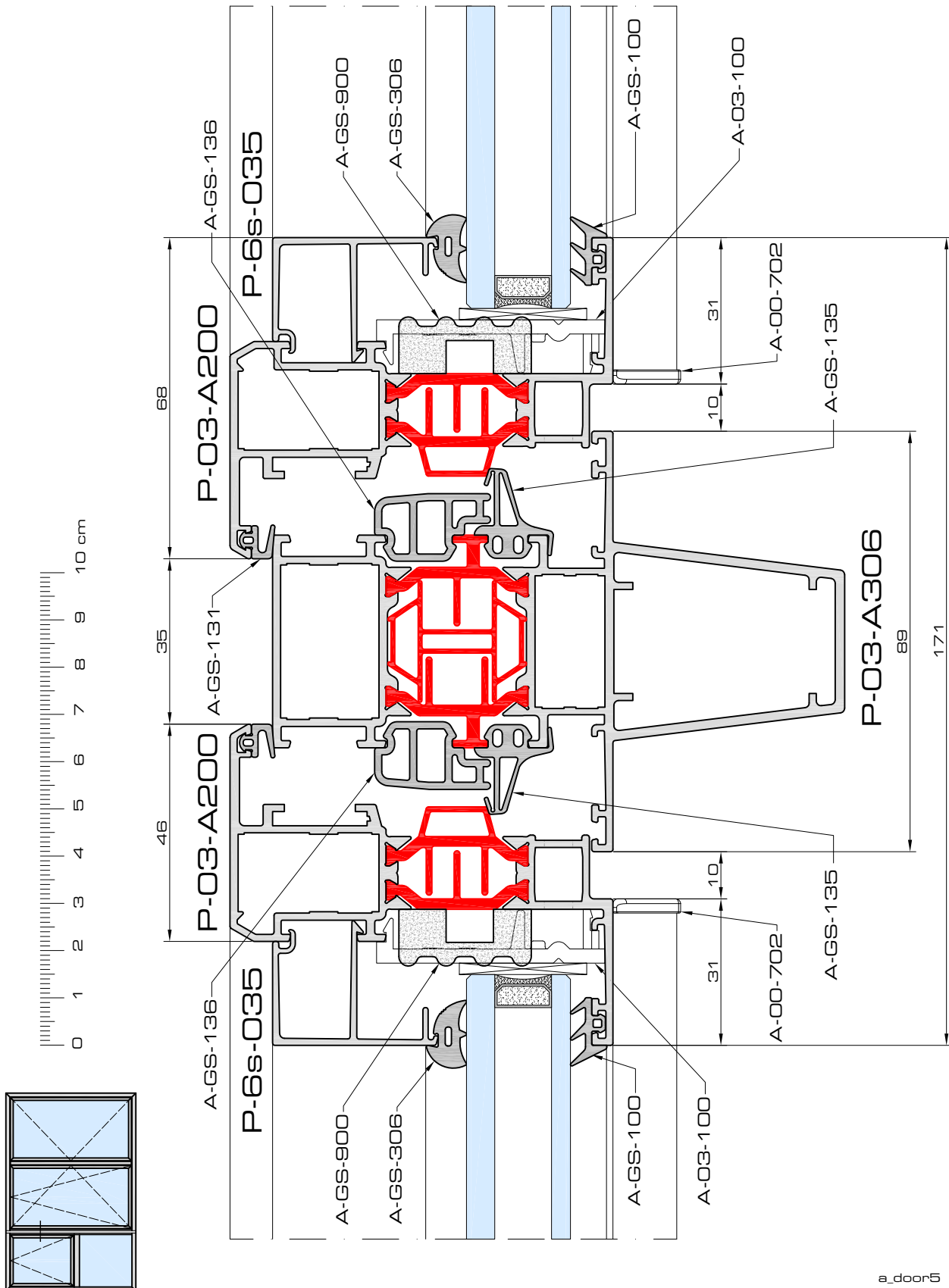

a_door5

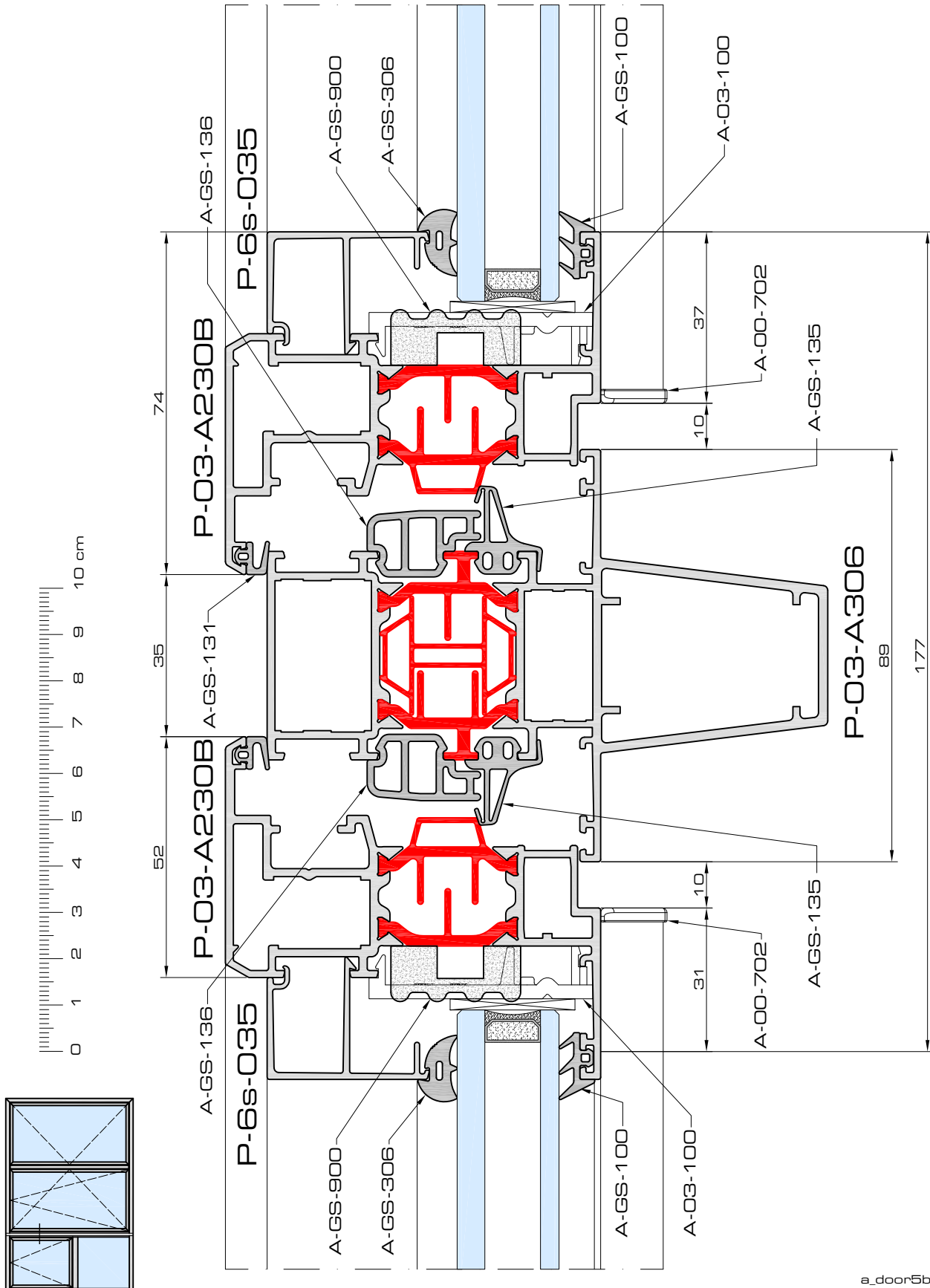

a_door5b

6a

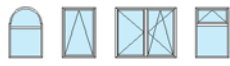

Triton 03

doorsneden - coupes - sections

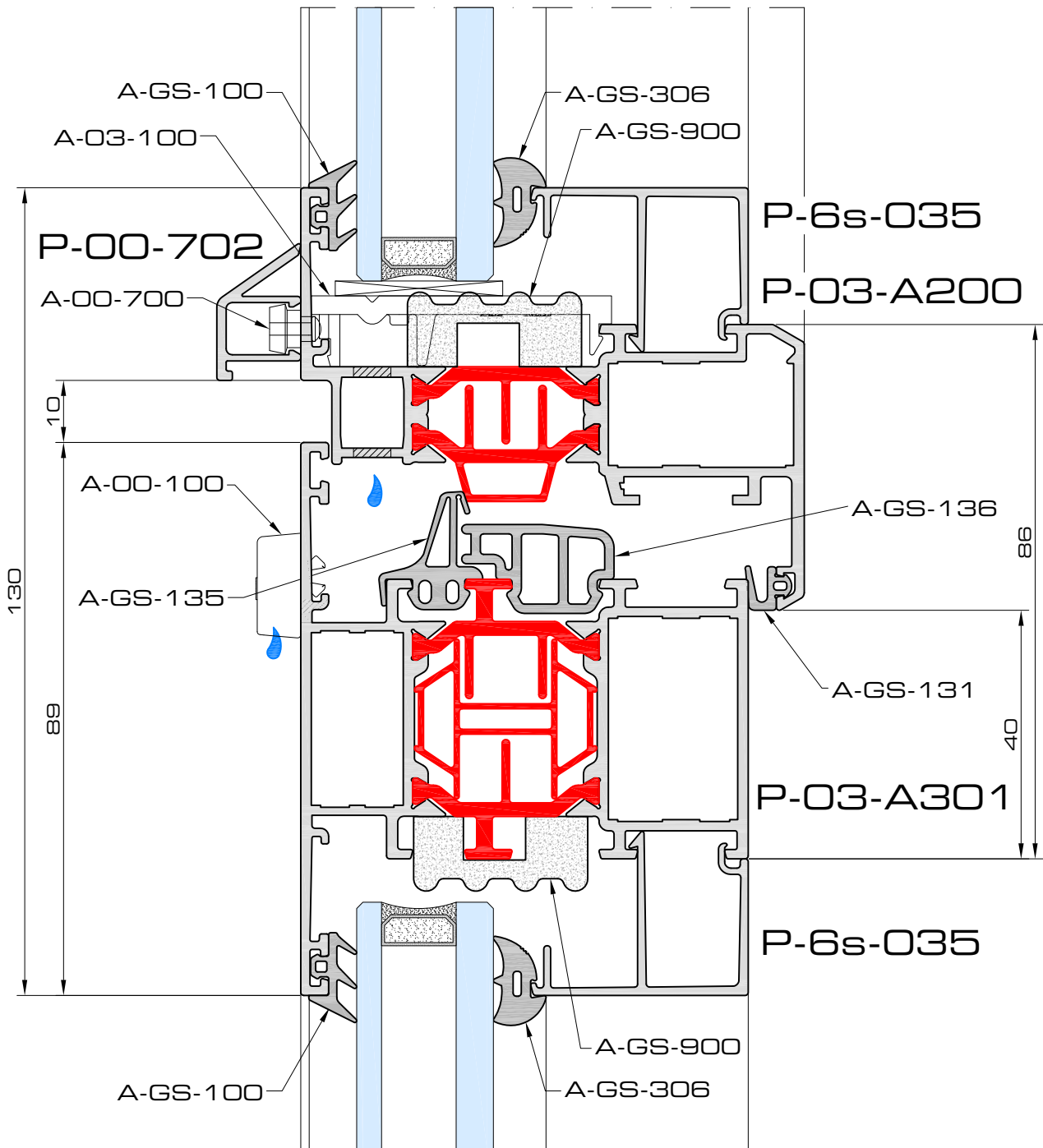
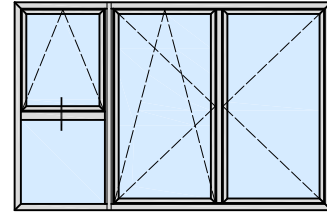

a door6a

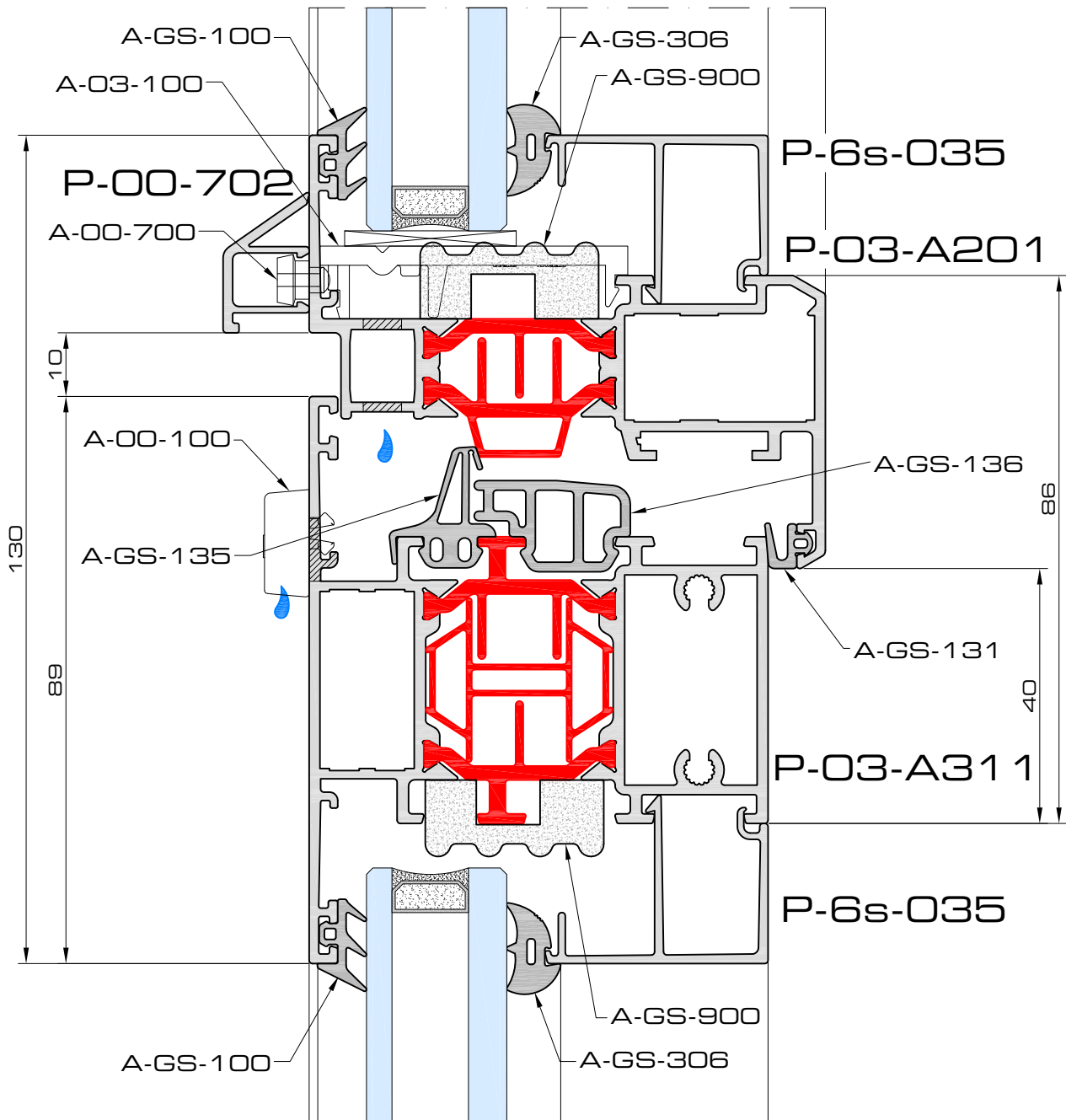
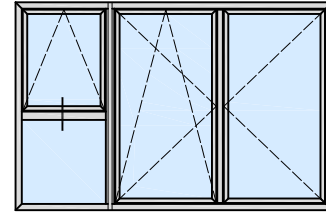
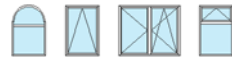

a door6b

6c

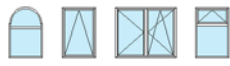

Triton 03

doorsneden - coupes - sections

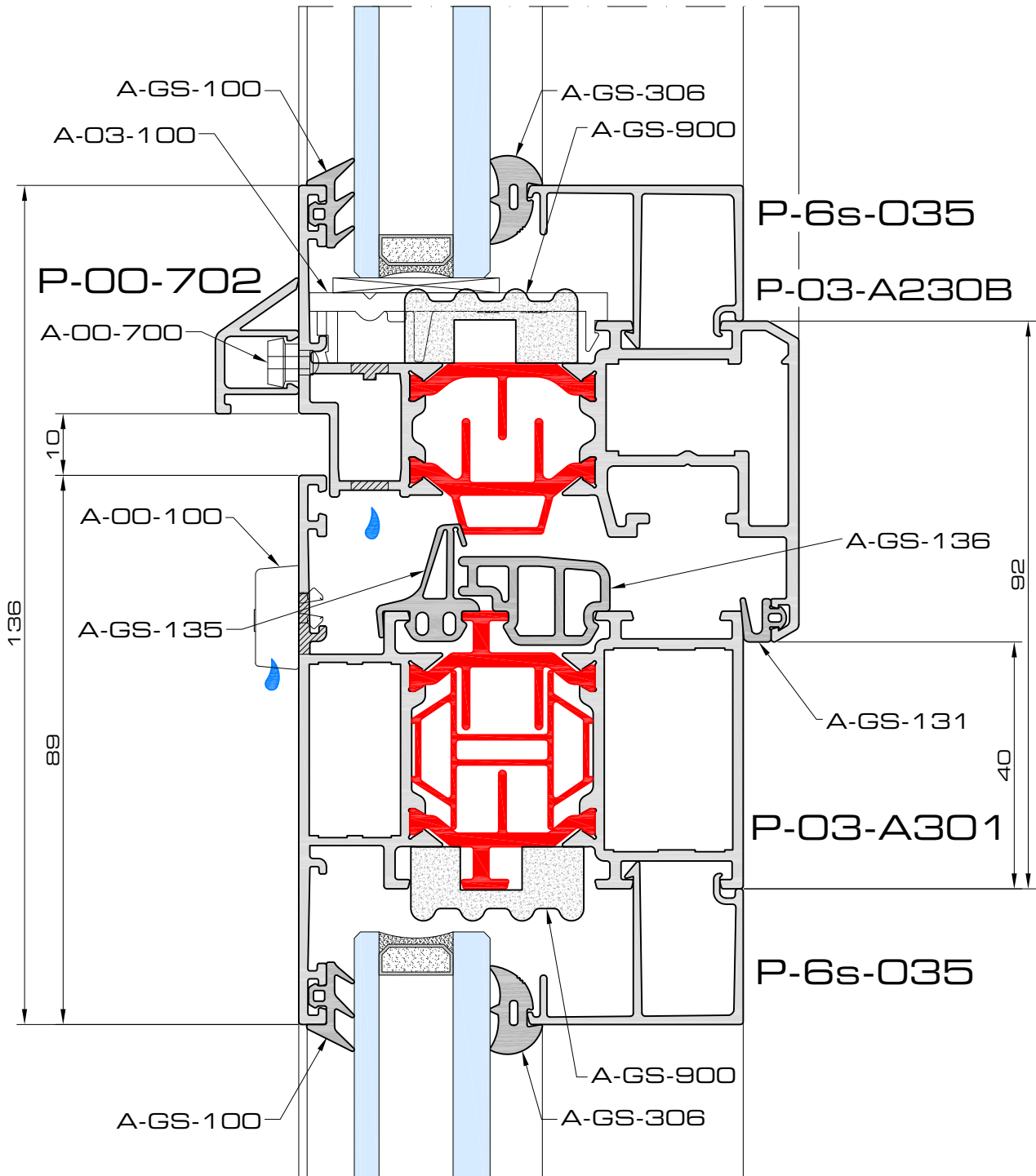
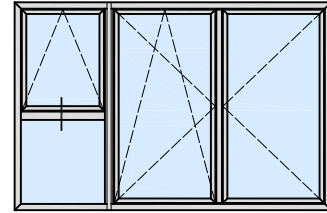

a door6c



Performances Triton system

atg 080806
Technical agreement

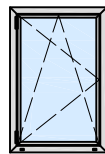

1230mm x 1480mm

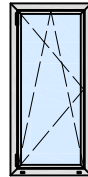

1200mm x 2325mm

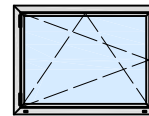

1448mm x 1173mm

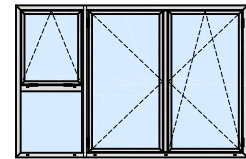

2640mm x 2200mm

		1230mm x 1480mm	1200mm x 2325mm	1448mm x 1173mm	2640mm x 2200mm
AIR PERMEABILITY EN 12207		class 4	class 4	class 4	class 4
WATER TIGHTNESS EN 12208		E2000A	E1600A	E1650A	E750A
WIND RESISTANCE EN 12211		C4	C4	C4	C3
OPERATION FORCE EN 13115 EN 12046-1		class 1	class 1	class 1	class 1
WRONG USE EN 13115		class 4	class 4	class 4	class 4
IMPACT EN 13049		class 5	-	-	class 3
REPORT		CAR 8246 12/12/2008	CAR 8246 10/12/2008	CAR 9026 27/02/2009	CAR 8246 18/12/2008
ACOUSTIC PERFORMANCE EN ISO 140-3 EN ISO 717-1		40 (-2;-6) dB	-	-	-
REPORT		AC 4765 04/11/2008			
BURGLARY PROOF NEN 5096/A1 ENV 1627		class 2	-	-	-
REPORT		ATT 09.11.295.02 system certificate			