

European Technical Assessment

ETA 06/0218

Version 01

Date of issue: 2018-06-25



UBAtc Assessment Operator:
Belgian Construction Certification Association
Rue d'Arlon 53 - 1040 Brussels
www.bcca.be - info@bcca.be



Technical Assessment Body issuing the European Technical Assessment: UBAtc.

UBAtc has been designated according to Article 29 of Regulation (EU) No 305/2011 and is member of EOTA (European Organisation for Technical Assessment)

Trade name of the construction product:

PROMATECT®-L500

Product family to which the construction product belongs:

Fire Protective board

Manufacturer:

ETEX BUILDING PERFORMANCE NV

Bormstraat 24

B-2830 Tiselt (Belgium)

Manufacturing plant(s):

ETEX BUILDING PERFORMANCE production plant 01 and 09

Website:

www.promat-international.com

This European Technical Assessment is issued in accordance with Regulation (EU) No 305/2011, on the basis of:

European Assessment Document (EAD):
EAD 350142-00-1106

This version replaces:

ETA 06/0218 issued on 2013/06/27

This European Technical Assessment contains:

20 pages, including 2 annexes, which form an integral part of the document.



European Organisation for Technical Assessment

Legal bases and general conditions

- 1 This European Technical Assessment is issued by UBAtc (Union belge pour l'Agrément technique de la construction, i.e. Belgian Union for technical Approval in construction), in accordance with:
 - Regulation (EU) No 305/2011¹ of the European Parliament and of the Council of 9 March 2011 laying down harmonised conditions for the marketing of construction products and repealing Council Directive 89/106/EEC
 - Commission Implementing Regulation (EU) No 1062/2013² of 30 October 2013 on the format of the European Technical Assessment for construction products
 - European Assessment Document:
EAD 3501-42-00-1106
- 2 Under the provisions of Regulation (EU) No 305/2011, UBAtc is not authorized to check whether the provisions of this European Technical Assessment are met once the ETA has been issued.
- 3 The responsibility for the conformity of the performances of the products with this European Technical Assessment and the suitability of the products for the intended use remains with the holder of the European Technical Assessment.
- 4 Depending on the applicable Assessment and verification of constancy of performance (AVCP) system, (a) notified body(ies) may carry out third-party tasks in the process of assessment and verification of constancy of performance under this Regulation once the European Technical Assessment has been issued.
- 5 This European Technical Assessment allows the manufacturer of the construction product covered by this ETA to draw up a declaration of performance for the construction product.
- 6 CE marking should be affixed to all construction products for which the manufacturer has drawn up a declaration of performance.
- 7 This European Technical Assessment is not to be transferred to other manufacturers, agents of manufacturers, or manufacturing plants other than those indicated on page 1 of this European Technical Assessment.
- 8 The European Technical Assessment holder confirms to guarantee that the product(-s) to which this assessment relates, is/are produced and marketed in accordance with and comply with all applicable legal and regulatory provisions, including, without limitation, national and European legislation on the safety of products and services. The ETA-holder shall notify the UBAtc immediately in writing of any circumstance affecting the aforementioned guarantee. This assessment is issued under the condition that the aforementioned guarantee by the ETA-holder will be continuously observed.
- 9 According to Article 11(6) of Regulation (EU) No 305/2011, when making a construction product available on the market, the manufacturer shall ensure that the product is accompanied by instructions and safety information in a language determined by the Member State concerned which can be easily understood by users. These instructions and safety information should fully correspond with the technical information about the product and its intended use, which the manufacturer has submitted to the responsible Technical Assessment Body for the issuing of the European Technical Assessment.
- 10 Pursuant to Article 11(3) of Regulation (EU) No 305/2011, manufacturers shall adequately take into account changes in the product-type and in the applicable harmonised technical specifications. Therefore, when the contents of the issued European Technical Assessment do not any longer correspond to the product-type, the manufacturer should refrain from using this European Technical Assessment as the basis for their declaration of performance.
- 11 All rights of exploitation in any form and by any means of this European Technical Assessment is reserved for UBAtc and the ETA-holder, subject to the provisions of the applicable UBAtc regulations.
- 12 Reproduction of this European Technical Assessment including transmission by electronic means shall be in full. However, partial reproduction can be made with the written consent of UBAtc. In this case partial reproduction has to be designated as such. Texts and drawings of advertising brochures shall not contradict or misuse the European Technical Assessment.
- 13 Subject to the application introduced, this European Technical Assessment is issued in English and may be issued by the UBAtc in its official languages. The translations correspond fully to the English reference version circulated in EOTA.
- 14 A European Technical Approval was issued by UBAtc on 27 June 2013. Compared with this European Technical Approval, the current European Technical Assessment, issued on 25 June 2018, comprises no technical changes, but editorial changes have been made to meet the requirements of the EAD. Production plant 04 has been deleted.

¹ OJEU, L 88 of 2011/04/04

² OJEU, L 289 of 2013/10/31

Technical Provisions

1 Technical description of the product

1.1 General

PROMATECT®-L500 is a fire protective calcium silicate board, mineral bound with mineral fillers. The board is off-white in appearance and has a smooth matte upper surface and a slightly coarse reverse face.

PROMATECT®-L500 is manufactured at ETEX BUILDING PERFORMANCE plants 01, 04 and 09 (known at UBAtc).

1.2 Dimensions and density

Dimensions and density of the boards are given in Table 1.

Table 1 : Dimensions and density PROMATECT®-L500

Density (dry 105°C): 480 kg/m ³ ± 15%		
Density (23°C, 50%RH): 500 kg/m ³ ± 15%		
Thickness (mm)	Length x width (mm)	Tolerances on length and width (mm)
20 ± 0,5	2500 x 1200	+3/-3
25 ± 0,5	2500 x 1200	+3/-3
30 ± 0,5	2500 x 1200	+3/-3
35 ± 0,5	2500 x 1200	+3/-3
40 ± 0,5	2500 x 1200	+3/-3
50 ± 0,5	2500 x 1200	+3/-3
50 ± 0,5	2440 x 1220	+3/-3
52 ± 0,5	2500 x 1200	+3/-3
60 ± 0,5	2500 x 1200	+3/-3

1.3 Ancillary products

Ancillary products referred to in this ETA, as a part of installation provisions or in the framework of determining performances (e.g. fire resistance test), are not covered by this ETA and may not be CE-marked on the basis of it.

2 Specification of the intended use(s) in accordance with the applicable EAD

2.1 Intended uses

This ETA covers fire protective PROMATECT®-L500 intended for:

- Internal use (EAD 350142-00-1106, type Z₂).
- internal use high humidity (EAD 350142-00-1106, type Z₁).

PROMATECT®-L500 is intended to protect elements or to be used in assemblies as specified in Table 2.

Table 2: Intended use

Protection of	EAD 350142-00-1106 reference
Horizontal membrane protection incl. suspended ceilings acc. to EN 13964	Type 1
Vertical membrane protection	Type 2
Load-bearing concrete elements	Type 3
Load-bearing steel elements	Type 4
Load-bearing flat concrete profiled sheet composite elements	Type 5
Load-bearing concrete filled hollow steel columns	Type 6
Load-bearing timber elements	Type 7
Fire separating assemblies with no load-bearing requirements	Type 8
Technical services assemblies in buildings	Type 9
Uses not covered by types 1-9	Type 10

Table 2 shows the possible intended uses of the boards. Not all of these have been assessed in the framework of this ETA with regard to fire resistance performance. Annex 2 shows a list of the uses for which fire resistance assessment was carried out. This ETA covers assemblies installed in accordance with the provisions given in Annex 2.

With regard to fire resistance performance, the other intended uses may be supported by other means at national level (as specified in the note in paragraph 3.2.2 of this ETA).

The provisions made in this European Technical Assessment are based on an assumed intended working life of 25 years, provided that the assembled product is subject to appropriate use and maintenance, in accordance with this ETA.

Indications given regarding the working life may not be interpreted as a guarantee given by the producer or the UBAtc, but shall be regarded only as a means for choosing the appropriate product(s) in relation to the expected economically reasonable working life of the construction works.

2.2 Assumptions

2.2.1 Manufacturing directives

This European Technical Assessment is issued for PROMATECT®-L500 boards on the basis of agreed data/information, deposited with the UBAtc, which identifies the product that has been assessed. Changes to the product/production process, which could result in the deposited data/information being incorrect should be notified to the UBAtc before the changes are introduced.

The main raw materials are mixed in water and blended in a reactor to form calcium silicate. This is combined in a mixer with the other raw materials to form thick slurry. The slurry is formed to a board. PROMATECT®-L500 boards are dried and edges are trimmed and the upper surface sanded to the specific thickness. Each board is marked in accordance with paragraph 6 of this ETA. PROMATECT®-L500 boards are examined for visual defects and non-compliant boards are rejected.

2.2.2 Installation

2.2.2.1 Supporting structure

The distance between supports shall be in accordance with the information provided in the assemblies described in annex 2.

2.2.2.2 Cutting and machining

The fire protective PROMATECT®-L500 boards shall be cut and machined using conventional woodworking equipment. Cutting shall be performed in accordance with EN 12101-7 paragraph B.1.2. The use of saw blades with hardened teeth or with tungsten carbide tipped blades is recommended. When machining the fire protective board with power tools, dust extraction shall take place and inhalation of dust should be avoided.

A safety data sheet is available from the manufacturer upon request.

2.2.2.3 Joints

The fire protective PROMATECT®-L500 boards shall be butt jointed.

The boards can have square or bevelled edges. The type of edge shall be in accordance with the assemblies described in annex 2.

Joints in adjacent boards, where possible, shall be staggered over a minimum distance of 300 mm.

The use and type of joint filler shall be in accordance with the assemblies described in annex 2.

2.2.2.4 Mechanical fasteners

Fastening of PROMATECT®-L500 boards onto the support structure shall be in accordance with the assembly information provided in annex 2.

When applied in more than one layer, the boards may be attached to each other by staples or equivalent mechanical fasteners (screws, nails), without an adverse effect on the mechanical properties of the assembled system.

2.2.2.5 Surface treatment

The PROMATECT®-L500 board surface allows for most types of decoration. When applying a surface treatment, the absorption capacity and alkalinity of the boards have to be taken into account.

Assessment of the influence of surface treatment (such as plastering, paints, tiles, wallpaper), on the performance of the PROMATECT®-L500 boards, has not been performed in the framework of this ETA.

2.2.2.6 Assembly

The PROMATECT®-L500 boards shall be applied as specified in the assemblies in annex 2.

2.3 Recommendations

2.3.1 Recommendations on packaging, transport and storage

During transport and storage, PROMATECT®-L500 boards should be stacked on a flat underground and covered. Storage should take place on pallets, in a sheltered and well-ventilated space.

2.3.2 Recommendations on use, maintenance and repair

Future modifications to the building should not adversely affect the fire protective properties of the system in which PROMATECT®-L500 boards are used. Care should be taken to prevent any reduction of fire performance as a result of increased applied load to protected elements of the works (e.g. beams, columns, ceilings, floors, or walls).

The assessment is based on the assumption that damage, for example caused by accidental impact, is repaired. It is further assumed that replacement of components during maintenance/repair will be undertaken using materials specified by the ETA.

3 Performance of the product and references to the methods used for its assessment

3.1 Mechanical resistance and stability (BWR1)

This basic requirement for construction works is not relevant for PROMATECT®-L500 boards according to EAD 350142-00-1106.

3.2 Safety in case of Fire (BWR2)

3.2.1 Reaction to fire

PROMATECT®-L500 boards have a reaction to fire classification A1 according to EN 13501-1.

3.2.2 Fire resistance

Assemblies incorporating PROMATECT®-L500 boards have a resistance to fire classified according to EN 13501-2 and EN 13501-3 as presented in Annex 2.

NOTE: This ETA covers a limited number of assemblies subjected to fire resistance assessment. As time progresses, the performance declaration for fire resistance covered by CE-marking should gradually be enlarged by the ETA-holder and incorporated in this ETA by amendment or revision. In the meantime, and taking into account the transitional arrangements for test and classification standards and the corresponding national legislation, the ETA-holder should be permitted to maintain and be able to use - on a national basis - his portfolio of test data for this characteristic, based on relevant national standards, next to the performance declaration covered by the CE-marking based on this ETA.

3.3 Hygiene, Health and the environment (BWR3)

3.3.1 Air and/or water permeability

This characteristic is not relevant for the intended use Z₂ (internal use).

3.3.2 Release of dangerous substances

No performance assessed.

3.4 Safety in Use (BWR4)

3.4.1 Flexural strength

In accordance with EN 12467, the PROMATECT®-L500 boards have a modulus of rupture (MOR) of ≥ 1,7 MPa (95% confidence level).

The PROMATECT®-L500 boards have sufficient strength to support their own mass. The PROMATECT®-L500 boards are not intended to support additional loads.

3.4.2 Dimensional stability

The PROMATECT®-L500 boards, tested in accordance with EN 318, are dimensionally stable.

3.4.3 Resistance to impact and eccentric load

No performance assessed.

3.5 Energy economy and heat retention (BWR6)

3.5.1 Thermal conductivity

No performance assessed.

3.5.2 Water vapour permeability

No performance assessed.

3.6 Protection against noise (BWR5)

3.6.1 Airborne sound insulation

No performance assessed.

3.6.2 Sound absorption

No performance assessed.

3.6.3 Impact sound insulation

No performance assessed.

3.7 Aspects of durability, serviceability and identification

3.7.1 Durability and serviceability

3.7.1.1 Resistance to deterioration caused by water

In accordance with EAD 3501 42 00 1106, the PROMATECT®-L500 boards are resistant to water deterioration.

3.7.1.2 Resistance to soak/dry

In accordance with EAD 3501 42 00 1106, the PROMATECT®-L500 boards are resistant to soak/dry cycles.

3.7.1.3 Resistance to freeze/thaw

This characteristic is not relevant for the intended use Z₂ (internal use) and Z₁ (internal use high humidity).

3.7.1.4 Resistance to heat/rain

This characteristic is not relevant for the intended use Z₂ (internal use) and Z₁ (internal use high humidity).

3.7.1.5 Basic durability assessment

Product performances confirm a working life of 25 years for the intended use Z₂ (internal use) and Z₁ (internal use high humidity).

3.7.2 Identification

3.7.2.1 Product properties

See §1 of this ETA.

3.7.2.2 Compressive strength

The compressive strength of the PROMATECT®-L500 boards, based on assessment testing in accordance with EAD 350142-00-1106 and EN 826, is 4,2 MPa. This value is a guidance value, and does not reflect a statistical evaluation, nor a minimum guaranteed value. This value is not intended to be used as a calculation value as basis for structural design.

3.7.2.3 Tensile strength

The perpendicular tensile strength of the PROMATECT®-L500 boards, based on assessment testing in accordance with EAD 350142-00-1106 and EN 1607, is 56,94 kPa.

The parallel tensile strength of the PROMATECT®-L500 boards, based on assessment testing in accordance with EAD 350142-00-1106 and EN 1608, is 445,43 kPa.

These values are guidance values, and do not reflect a statistical evaluation, nor minimum guaranteed values. These values are not intended to be used as calculation values as basis for structural design.

4 Assessment and verification of constancy of performance (AVCP) system applied, with reference to its legal base

In accordance with Regulation (EU) N° 305/2011, Article 65, Directive 89/106/EEC is repealed, but references to the repealed Directive shall be construed as references to the Regulation.

The system of assessment and verification of constancy of performance, specified in the Decision of the Commission 1999/454/EC of 1999/07/14³, as amended, is specified in the following Table.

Table 3– System of assessment and verification of constancy of performance applicable to PROMATECT®-L500

Product(s)	Intended use(s)	Level(s) or class(es)	Assessment and verification of constancy of performance
Fire Protective Products	For fire compartmentation and/or fire protection or fire performance	Any	1
* See Annex V to Regulation (EU) N° 305/2011			

³ see OJEU L178/52 of 1999/07/14

In addition, according to the decision 1999/454/EC of 1999/07/14³ of the European Commission, as amended, the systems of assessment and verification of constancy of performance specified in table 4 apply to fire protective products with regard to reaction to fire.

Table 4– Systems of assessment and verification of constancy of performance with respect to the reaction to fire

Product(s)	Intended use(s)	Level(s) or class(es) (reaction to fire)	Assessment and verification of constancy of performance system(s) ^a
Fire Protective Products	For uses subject to regulations on reaction to fire	(A1, A2, B, C)*	1
		(A1, A2, B, C)**; D, E, F	3
		(A1 to F)***, NPD****	4
^a Systems 1, 3 and 4 : See Regulation (EU) N° 305/2011, Annex V * Products/materials for which a clearly identifiable stage in the production process results in an improvement of the reaction to fire classification (e.g. an addition of fire retardants or a limiting of organic material) ** Products/materials not covered by footnote (*) *** Products/materials that do not require to be tested for reaction to fire (e.g. products/materials of class A1 according to Commission Decision 96/603/EC ⁴ , as amended) **** 'No Performance Declared' in accordance with Regulation (EU) N° 305/2011, Article 6(f) ^a Systems 1 and 2+ :See Regulation (EU) N° 305/2011, Annex V			

5 Technical details necessary for the implementation of the AVCP system, as foreseen in EAD 350142-00-1106

5.1 Tasks for the ETA-holder

5.1.1 Factory production control (FPC)

The ETA-holder shall exercise permanent internal control of the production. All the elements, requirements and provisions adopted by the ETA-holder shall be documented in a systematic manner in the form of written policies and procedures. This factory production control system shall ensure that production is in conformity with this ETA.

The personnel involved in the production process shall be identified, sufficiently qualified and trained to operate and maintain the production equipment. Machinery equipment shall be regularly maintained and this shall be documented. All processes and procedures of production shall be recorded at regular intervals.

The ETA-holder shall maintain a traceable documentation of the production process from purchasing or delivery of raw or basic raw materials up to the storage and delivery of finished products.

The factory production control system for the product includes relevant design specifications, including adequate drawings and written instructions for:

- type and quality of all materials
- overall dimensions
- packaging and transport protection

The production control system shall specify how the control measures are carried out, and at which frequencies.

ETA-holders which have an FPC system that complies with EN ISO 9001 and that addresses the requirements of this ETA are recognised as satisfying the FPC requirements.

Products that do not comply with requirements as specified in the ETA shall be separated from the conforming products and marked as such. The ETA-holder shall register non-compliant production and action(-s) taken to prevent further non-conformities. External complaints shall also be documented, as well as actions taken.

When materials/products are delivered for incorporation into the production process, verification of conformity with specifications in the quality manual shall take place and be recorded.

If supplied materials/components are not manufactured and tested by the supplier in accordance with agreed methods, or where the ETA-holder purchases materials/components on the open market, then where appropriate, they shall be subject to suitable documented checks/tests by the ETA-holder before acceptance.

The characteristics of incoming material and components, for which the supplier demonstrates documented compliance with a product specification, for an intended use that is appropriate for its use as a raw material or component of the product, shall be considered satisfactory and need, except in justified doubt, no further checking, unless the control plan specifies differently.

5.1.2 Testing of samples taken at the factory

5.1.2.1 General

At least the following minimum information shall be recorded:

- date and time of manufacture
- type of product produced (boards)
- material specification (dimensions and thickness)
- all results of the verifications performed within the agreed upon control plan

5.1.2.2 Maintenance, checking and calibration of equipment

All testing equipment shall be maintained, calibrated and/or checked against equipment or test specimens traceable to relevant international or nationally recognised reference test specimens (standards). In case no such reference test specimens exist, the basis used for internal checks and calibration shall be documented.

The ETA-holder shall ensure that handling, preservation and storage of test equipment is such that the performances are maintained

⁴ see OJEU L267 of 1996/10/19

When production is intermittent, the ETA-holder shall ensure that any test equipment which may be affected by the interruption is suitably checked and/or calibrated before use. The calibration of all test equipment shall be repeated if any repair or failure occurs which could upset the calibration of the test equipment.

5.1.2.3 Testing as part of Factory Production Control

Table 5 specifies minimum requirements for testing as part of FPC.

If constituent materials or components are supplied by other manufacturers to the ETA-holder, the supplier shall perform FPC on those constituent materials or components. If that is the case, those suppliers should submit the relevant records to the ETA-holder.

Table 5 : FPC test plan for PROMATECT®-L500

Property	Minimum frequency
Determination of organic content (reaction to fire)	1 per week ⁵
Determination of dimensional stability at high temperatures (fire resistance)	1 per week
Indirect test method (small oven test) ⁶	1 per year
Dimensional stability	1 per year
Identification	
length, width	1 per day ⁷ , per dimension
thickness	1 per day, per thickness
apparent density	1 sample per n boards
Flexural strength	1 sample per n boards

5.2 Initial Type Testing

The assessment tests will have been conducted by the UBAtc or under its responsibility (which may include a proportion conducted by an independent laboratory or by the ETA-applicant, witnessed by the UBAtc). The UBAtc will have assessed the results of these tests in accordance with chapter 3 of this ETA, as part of the ETA issuing procedure.

The results of assessment testing shall be used by notified bodies (cf. Regulation (EU) 305/2011, Annex V, clause 1.6).

6 Other marking and/or information

Each board shall at least be marked with product name and a traceability code. Each package is marked with the product name, traceability code, thickness of the boards, and dimensions of the boards.

⁵ A week represents 5 production days.

⁶ Production shall be subjected to a small oven test (test performed on one thickness).

⁷ A day represents a 24h time period in which production is considered to be as usual for the production facility concerned.

UBAtc asbl is a non-profit organization according to Belgian law. It is a Technical Assessment Body notified by the Belgian notifying authority, the Federal Public Services Economy, SMEs, Self-Employed and Energy, on 17 July 2013 in the framework of Regulation (EU) No 305/2011 of the European Parliament and of the Council of 9 March 2011 laying down harmonised conditions for the marketing of construction products and repealing Council Directive 89/106/EEC and is member of the European Organisation for Technical Assessment, EOTA (www.eota.eu).

This European Technical Assessment has been issued by UBAtc asbl, in Sint-Stevens-Woluwe, on the basis of the technical work carried out by the Assessment Operator, BCCA.

On behalf of UBAtc asbl,

On behalf of the Assessment Operator, BCCA, responsible for the technical content of the ETA,



Peter Wouters,
director



Benny De Blaere,
director general

The most recent version of this European Technical Assessment may be consulted on the UBAtc website (www.ubatc.be).

Annex I: References

Reference number EAD 350142-00-1106

Document title Fire protective products - Fire protective board, slab and mat products and kits.

Reference number EN 13964:2004

Document title Suspended ceilings - Requirements and test methods.

Reference number EN 13501-1:2002

Document title Fire classification of construction products and building elements - Part 1: Classification using test data from reaction to fire tests

Reference number EN 13501-2:2003

Document title Fire classification of construction products and building elements - Part 2: Classification using data from fire resistance tests, excluding ventilation services

Reference number EN 13501-3:2005

Document title Fire classification of construction products and building elements - Part 3: Classification using data from fire resistance tests on products and elements used in building service installations: fire resisting ducts and fire dampers

Reference number EN 1366-1:1999

Document title Fire resistance tests for service installations – Part 1: Ducts

Reference number EN 12467:2004

Document title Fibre-cement flat sheets - Product specification and test methods

Reference number EN 318:2002

Document title Wood based panels - Determination of dimensional changes associated with changes in relative humidity

Reference number EN 826:1996

Document title Thermal insulating products for building applications - Determination of compression behaviour

Reference number EN 1607:1996

Document title Thermal insulating products for building applications - Determination of tensile strength perpendicular to faces

Reference number EN 1608:1996

Document title Thermal insulating products for building applications - Determination of tensile strength parallel to faces

Reference number EN 10034:1993

Document title Structural steel I and H sections - Tolerances on shape and dimensions

Reference number EN 14195:2005

Document title Metal framing components for gypsum plasterboard systems – Definitions, requirements and test methods

Reference number prEN 14566 (September 2002)

Document title Mechanical fasteners for gypsum plasterboard systems – Definitions, requirements and test methods.

Reference number EN 13162:2001

Document title Thermal insulation products for buildings - Factory made mineral wool (MW) products – Specification

NOTE: The editions of reference documents given above are those, which have been adopted by the UBAtc for its specific use when establishing this ETA. When new editions become available, these supersede the editions mentioned only when confirmed by the UBAtc.

Annex II : Fire resistance performances and assembly methods for uses of boards covered by this ETA

A 2.0 Overview of fire resistance performances for PROMATECT®-L500 assemblies

The fire protective assemblies in Table A.2.1 have been assessed within the framework of this ETA. Assemblies installed according to the provisions given in this annex are covered by this ETA.

Table A 2.0.1

Assemblies assessed within the framework of this ETA	Classification according to EN 13501-2/3	Test Standard	Intended use category according to EAD 350142-00-1106	Installation details	Date of addition to this ETA
Horizontal duct type A, composed of PROMATECT®-L500 fire protective board (thickness 30 mm), exposed to fire from the outside	EI 120 (ho o → i) S	EN1366-1	Type 9	Annex 2.1	19/04/2007
Vertical duct type B, composed of PROMATECT®-L500 fire protective board (thickness 60 mm), exposed to fire from the inside	EI 180 (ve i → o)	EN1366-1	Type 9	Annex 2.2	19/04/2007

Annex 2.1: Specification of a horizontal duct type A (intended use type 9), composed of PROMATECT®-L500 fire protective board (thickness 30 mm), exposed to fire from the outside

A.2.1.1 Date of addition to this ETA

This annex was added to ETA 06/0218 on 19/04/2007. This assembly was not covered by this ETA prior to the addition of this annex.

A.2.1.2 Classification

The assembly described in this annex has been tested according to EN 1366-1 and classified EI 120 (ho o → i) S in accordance with EN 13501-3. The permitted operation pressure of the duct is atmospheric pressure ± 300 Pa.

A.2.1.3 Installation requirements

Installation requirements in paragraph 2.2.2 of this ETA shall be taken into account.

A.2.1.4 Supporting structure

The continuous self-supporting horizontal duct is composed of PROMATECT®-L500 boards (thickness 30 mm) (see paragraph A.2.1.6 for details of the duct composition). The duct penetrates a lightweight masonry wall with a minimum thickness of 150 mm (clearance of ca 30 mm between duct and wall).

The duct is supported by suspension hangers placed at intervals of 1200 mm, as illustrated by figure A.2.1.1.

The suspension hangers consist of steel rods with a minimum diameter M10 and steel L channels with minimum section dimensions of 40/40/4 (mm). The suspension hangers will be spaced at maximum 1200 mm centres. The distance between the steel rods and the duct wall is ≤ 50 mm.

The tensile stress in the supporting components shall not exceed 9 N/mm².

The supporting structure is not protected.

Specifications for the components are given in Table A.2.1.1.

Table A.2.1.1			
Element	Identification	Characteristics	Mounting and fixing
L channels	Galvanized steel channels according to EN 14195 or equivalent	Dimensions: $\geq 40/40/4$ (mm) Length: corresponding with duct dimensions	Installed at ≤ 1200 mm centres
Rods	Galvanized steel rods	$\geq M10$	Installed at ≤ 1200 mm centres. The distance between the steel rods and the duct wall is ≤ 50 mm.

A.2.1.5 Insulation

None.

A.2.1.6 Fire protective boards

The PROMATECT®-L500 boards (thickness 30mm) are placed to form a continuous horizontal duct as shown in figure A.2.1.1.

The boards are fixed together with PROMAT® K84 glue (see A.2.1.7.1 for characteristics) on all edges and screwed in the edges with steel screws with minimum dimensions of $\varnothing 4 \times 70$ mm, at maximum 120 mm centres. The joints are staggered at 600 mm intervals between joints in horizontal and vertical faces.

The maximum dimensions of the duct section are 1250 mm x 1000 mm, as shown in figure A.2.1.2.

Specifications for the components are given in Table A.2.1.2.

Table A.2.1.2			
Element	Identification	Characteristics	Mounting and fixing
Boards	Fire protective board PROMATECT®-L500	Length: 2500 mm Width: 1200 mm Thickness: 30 mm	Installed to form a rectangular horizontal duct. Joints staggered at 600 mm intervals.
Screws	Galvanized steel screws according to prEN 14566 or equivalent	≥ Ø 4 x 70 mm	Fixing of the boards at ≤ 120 mm centers

A.2.1.7 Joints

A.2.1.7.1 Board joints

All internal and external joints are filled and finished with PROMAT® K84 glue as shown in the details in figures A.2.1.4 to A.2.1.12. The filled joints are the result of application of glue when forming the duct structure.

Specifications for the components are given in Table A.2.1.3.

Table A.2.1.3			
Element	Identification	Characteristics	Mounting and fixing
Glue	PROMAT® K84 glue	Viscous glue based on sodium silicate with addition of inorganic charges. It is grey or off-white in color and intumesces slightly in case of fire. The glue is supplied in canisters of 15 kg.	The glue is applied with a spatula. The joints are completely filled up.

A.2.1.7.2 Penetration seal

The joint between the penetration wall and the duct (free space of ca 30 mm) is filled with fire protective foam PROMAFOAM®-C (or equivalent). On both sides of the wall along the entire perimeter of the duct, custom-made L profiles are applied (see figure A.2.1.12). The L profiles are made out of PROMATECT®-L500 fillets (thickness 30 mm) with a minimum width of 100 mm, fixed together with steel screws with minimum dimensions of Ø 4 x 70 mm, at maximum 200 mm centres. The L profiles are fixed to the wall with steel screws with minimum dimensions of Ø 4 x 70 mm, at maximum 200 mm centres.

All joints and surfaces in contact with each other are glued with PROMAT® K84 glue (see A.2.1.7.1 for characteristics).

Specifications for the components are given in Table A.2.1.4.

Table A.2.1.4			
Element	Identification	Characteristics	Mounting and fixing
Custom-made L profile	Fire protective board PROMATECT®-L500	Width: ≥ 100 mm Thickness: 30 mm	Installed around the duct and fixed to the wall at ≤ 200 mm centres.
Sealant	PROMAFOAM®-C (or equivalent)	Fire protective foam based on modified polyurethane. After application it has a closed cellular structure. It is grey in colour. The foam is supplied in spray cans of 700 ml. One can represents 25 to 30 liters of foam by free expansion.	The sealant is sprayed.
Screws	Galvanized steel screws according to prEN 14566 or equivalent	≥ Ø 4 x 70 mm	Fixing of the L profiles at ≤ 200 mm centers.

A.2.1.8 Details

All installation details shall be executed as presented in the figures on paragraph A.2.1.9.

A.2.1.9 Figures

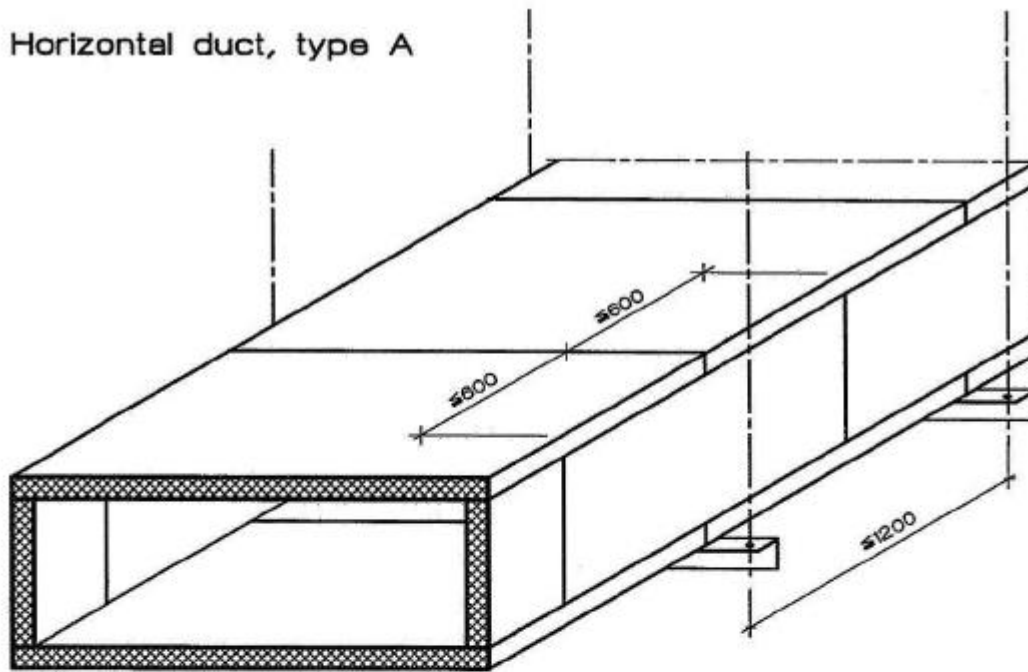

Figure A.2.1.1 Suspension hangers

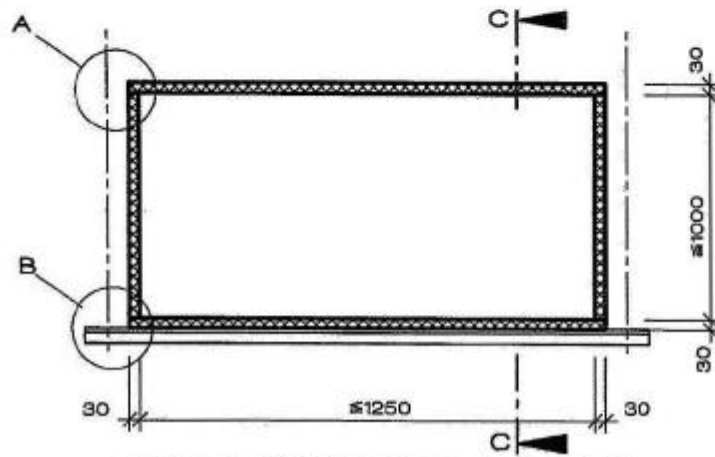

Figure A.2.1.2 Overview of the duct

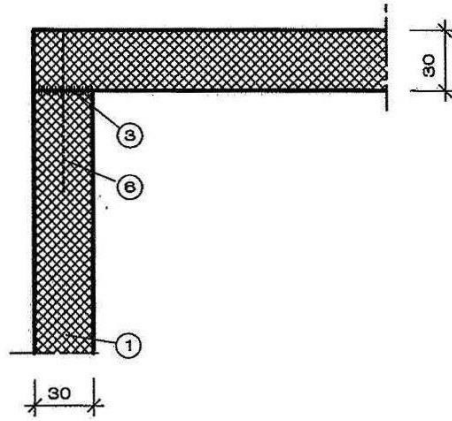

Figure A.2.1.3
Detail A

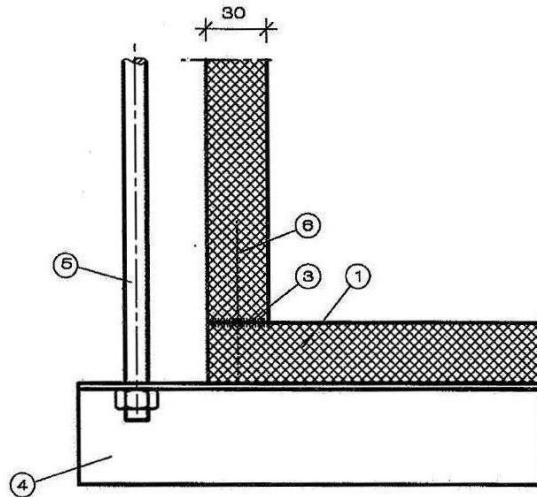

Figure A.2.1.4
Detail B

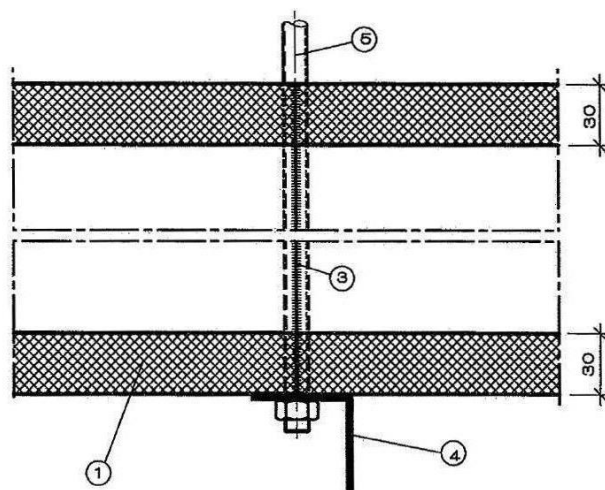

Figure A.2.1.5
Section C-C

Dimensions in mm

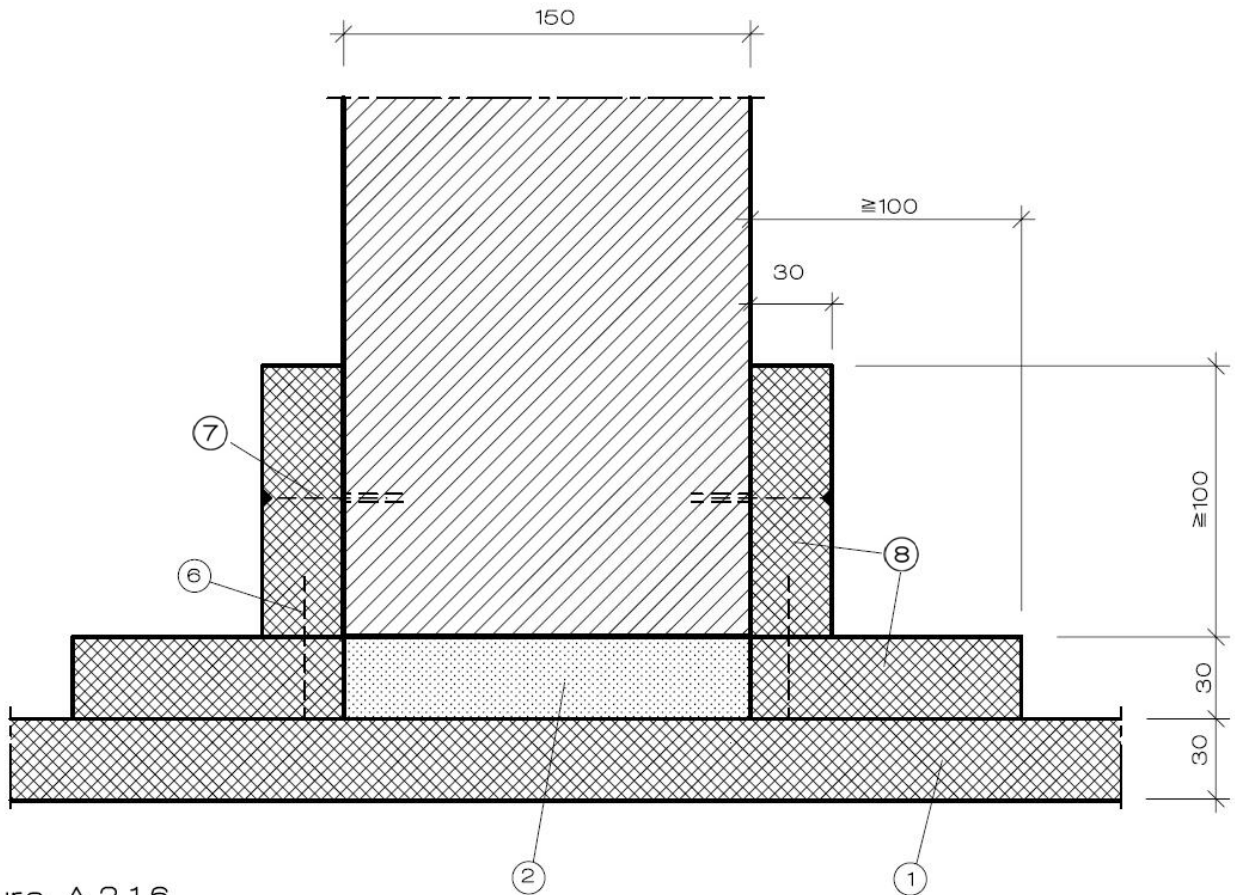

Figure A.2.1.6
wall penetration

Key

- ① PROMATECT®-L500 boards, 30 mm th.
- ② Fire protective foam PROMAFOAM®-C (or equivalent)
- ③ Promat K84 glue
- ④ L channel, $\geq 40/40/4$ mm, spacing ≤ 1200 mm
- ⑤ Rod, $\geq M10$, spacing ≤ 1200 mm
- ⑥ Screw, $\geq \varnothing 4 \times 70$ mm (or equivalent)
- ⑦ Screw with dowel, spacing ≤ 500 mm
- ⑧ PROMATECT®-L500 board strips, 30 mm th.

Annex 2.2: Specification of a vertical duct type B (intended use type 9), composed of PROMATECT®-L500 fire protective board (thickness 60 mm), exposed to fire from the inside

A.2.2.1 Date of addition to this ETA

This annex was added to ETA 06/0218 on 19/04/2007. This assembly was not covered by this ETA prior to the addition of this annex.

A.2.2.2 Classification

The assembly described in this Annex has been tested according to EN 1366-1 and classified EI 180 (ve i → o) in accordance with EN 13501-3.

A.2.2.3 Installation requirements

Installation requirements in paragraph 4.2 of this ETA shall be taken into account.

A.2.2.4 Supporting structure

The continuous self-supporting vertical duct is composed of PROMATECT®-L500 fire protective boards (thickness 60 mm) (see paragraph A.2.2.6 for details of the duct composition). The duct starts at ground level and penetrates a steel reinforced concrete floor with a minimum thickness of 170 mm. At the opening in the floor (see paragraph A.2.2.7.2 for dimensions of the opening), the duct is supported along the entire perimeter by steel L channels and board fillets, as shown in figure A.2.2.1. (See paragraph A.2.2.7.2 for details on the penetration seal.)

The steel L channels have minimum dimensions of 50/50/5 (mm) and are fixed at the perimeter of the concrete opening by steel anchors with minimum dimensions M8, at least 2 per channel.

The PROMATECT®-L500 fillets (thickness 60 mm) are applied in a double layer around the duct by means of screws with minimum dimensions of Ø 4,8 x 100 mm at maximum 150 mm centres.

Specifications for the components are given in Table A.2.2.1.

Table A.2.2.1			
Element	Identification	Characteristics	Mounting and fixing
L channels	Galvanized steel channels according to EN 14195 or equivalent	≥ 50/50/5 (mm)	Installed in the opening of the concrete floor.
Steel anchor	Steel anchor	≥ M8	Used for fixing of the L channels (≥ 2 anchors per L channel)
Board fillets	Fire Protective Board PROMATECT®-L500	Thickness: 60 mm width: ≥ 100 mm	Fixed around the perimeter of the duct in a double layer
Screws	Galvanized steel screws according to prEN 14566 or equivalent	≥ Ø 4,8 x 100 mm	Used for fixing of the board fillets at ≤ 150 mm centres

A.2.2.5 Insulation

None.

A.2.2.6 Fire protective boards

The PROMATECT®-L500 boards (thickness 60mm) are placed to form a continuous vertical duct as shown in figure A.2.1.2. The boards are fixed together with PROMAT® K84 glue (see A.2.2.7.1 for characteristics) at all edges and screwed in the edges with steel screws with minimum dimensions of Ø 5 x 100 mm at maximum 150 mm centres.

The horizontal joint between 2 sections is covered with PROMATECT®-L500 fillets with a minimum thickness of 30 mm and a minimum width of 150 mm, fixed with PROMAT® K84 glue (see A.2.2.7.1 for characteristics) and with screws with minimum dimensions of Ø 4 x 70 mm at maximum 150 mm centres.

The maximum dimensions of the duct are 1000 mm x 250 mm, as shown in figure A.2.2.3.

Specifications for the components are given in Table A.2.2.2.

Table A.2.2.2			
Element	Identification	Characteristics	Mounting and fixing
Boards	Fire Protective board PROMATECT®-L500	Length: 2500 mm Width: 1200 mm Thickness: 60 mm	Installed to form a rectangular vertical duct
Screws	Galvanized steel screws according to prEN14566 or equal	Ø 5 x 100 mm	Used for fixing of the boards at ≤ 150 mm centres
Board fillets	Fire Protective board PROMATECT®-L500 according to the ETA for this product	Thickness: ≥ 30 mm Width: ≥ 150 mm	Glued and screwed at ≤ 150 mm centres
Screws	Galvanized steel screws according to prEN14566 or equivalent	Ø 4 x 70 mm	Used for fixing of the board fillets at ≤ 150 mm centres

A.2.2.7 Joints

A.2.2.7.1 Board joints

All internal and external joints are filled and finished with PROMAT® K84 glue as shown in the details in figure A.2.2.2. The filled joints are the result of application of glue when forming the duct structure.

Specifications for the components are given in Table A.2.2.3.

Table A.2.2.3			
Element	Identification	Characteristics	Mounting and fixing
Glue	PROMAT® K84 glue	Viscous glue based on sodium silicate with addition of inorganic charges. It is grey or off-white in color and intumesces slightly in case of fire. The glue is supplied in canisters of 15 kg.	The glue is applied with a spatula. The joints are completely filled up.

A.2.2.7.2 Penetration seal

The gap between the floor and the duct shall be 125-190 mm. The gap is filled with mineral wool, with an A1 classification according to EN 13501-1 and a minimum density of 145 kg/m³ (see figure A.2.2.1).

At the bottom side of the floor, a horizontal layer of PROMATECT®-L500 board fillets with a minimum thickness of 30 mm and a minimum width of 250 mm (fit closely to the perimeter of the duct and supporting the mineral wool) is fixed to the floor by means of steel anchors with minimum dimensions of M6, 2 per fillet (see figure A.2.2.1).

At the bottom side of the floor, a vertical layer of PROMATECT®-L500 board fillets with a minimum thickness of 30 mm and a minimum width of 70 mm (fit closely to the 250 mm wide PROMATECT®-L500 board fillets) is screwed to the duct with screws with minimum dimensions of Ø 4,8 x 70 mm at maximum 150 mm centers (see figure A.2.2.1).

Along the mineral wool fill, a self-adhesive intumescent strip (PROMASEAL®-LF or PROMASEAL®-PL) with a minimum thickness of 2 mm and a minimum width of 15 mm, is fixed on the 250 mm wide PROMATECT®-L500 fillet all around the duct, at a distance of 60 mm from the duct (see figure A.2.2.1).

At the upper side of the floor, a horizontal layer of PROMATECT®-L500 board fillets with a minimum thickness of 30 mm and a minimum width of 200 mm (fit closely to the double vertical layer of PROMATECT®-L500 fillets) is fixed around the duct. The fillets are fixed to the floor with anchors with minimum dimensions M6, 2 per fillet (see figure A.2.2.1).

The opening between the L channels and the double layer of PROMATECT®-L500 board fillets (see paragraph A.2.2.4 for details of the supporting structure) is filled with mineral wool, with an A1 classification according to EN 13501-1 and a minimum density of 145 kg/m³ (see figure A.2.2.1).

Specifications for the components are given in Table A.2.2.4.

Table A.2.2.4			
Element	Identification	Characteristics	Mounting and fixing
Board fillets	Fire Protective board PROMATECT®-L500 according to the ETA for this product	Thickness: ≥ 30 mm	Fixed along the entire perimeter of the duct
		Width: ≥ 250 mm	Fixed horizontally under the floor with anchors
		Width: ≥ 70 mm	Fixed vertically under the floor with screws
		Width: ≥ 200 mm	Fixed horizontally above the floor with anchors
Anchors	Galvanized steel anchors	≥ M6	Used for fixing of the board fillets (≥ 2 per fillet)
Screws	Galvanized steel screws according to prEN 14566 or equivalent	≥ Ø 4,8 x 70 mm	Used for fixing of the board fillets at ≤ 150 mm centres
Intumescent strip	Intumescent strip PROMASEAL®-LF or PROMASEAL®-PL	Thickness: ≥ 2 mm Width: ≥ 15 mm Flexible, black, self-adhesive strip. The strip intumesces in case of fire.	Fixed with the adhesive side to the 30 mm board strips
Sealing material	Mineral wool according to EN 13162	Thickness and width to fill the gap Density: ≥ 145 kg/m ³	Cut to size and installed between the penetration floor and the duct and between the L channels and the board fillets

A.2.2.8 Details

All installation details shall be executed as presented in the figures in paragraph A.2.2.9.

A.2.2.9 Figures

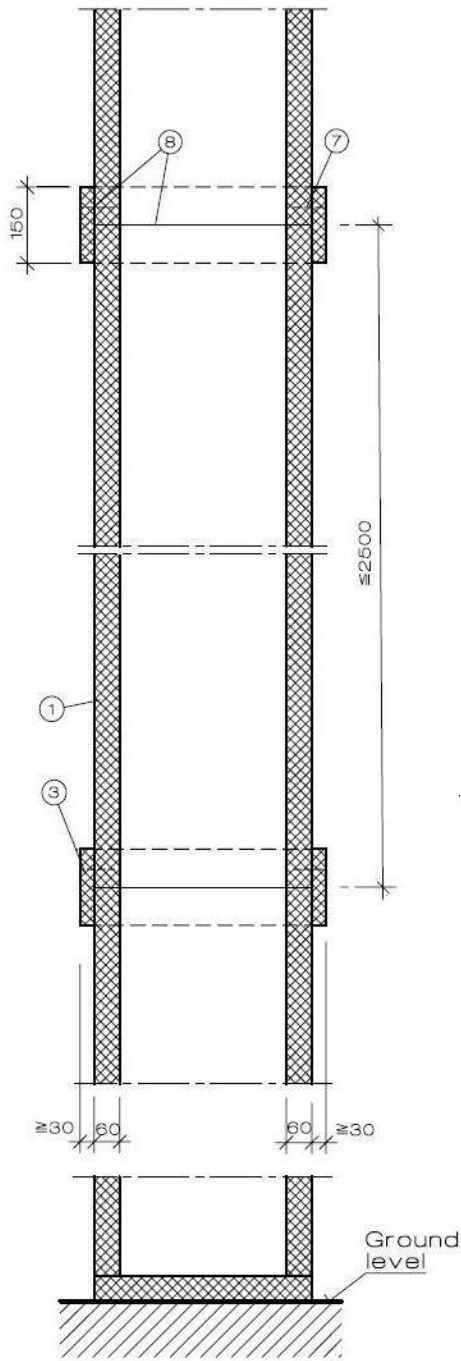

Figure A.2.2.2 Vertical section

Vertical duct, type B

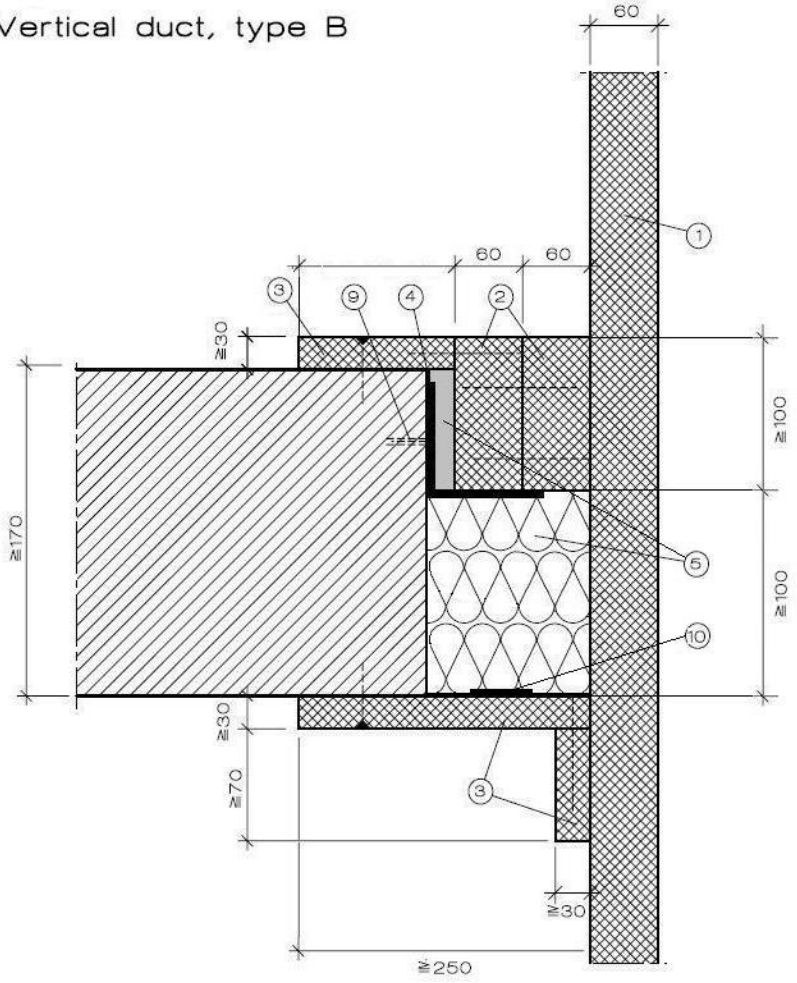

Figure A.2.2.1
Concrete floor penetration

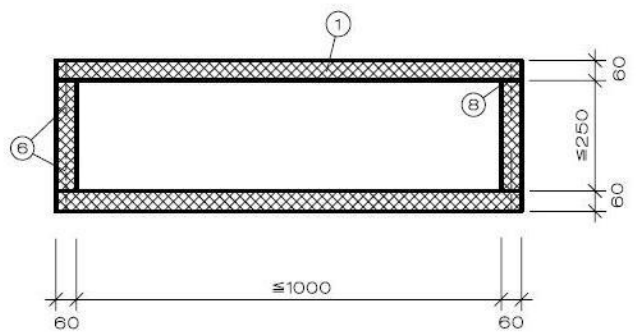

Figure A.2.2.3 Overview of the duct

Key

- ① PROMATECT®-L500 boards, 60 mm th.
- ② PROMATECT®-L500 fillets, 60 mm th.
- ③ PROMATECT®-L500 fillets, 30 mm th.
- ④ L channel, $\geq 50/50/5$ mm
- ⑤ Mineral wool, density ≥ 145 kg/m³
- ⑥ Screw, $\geq \text{Ø } 5 \times 100$ mm (or equivalent)
- ⑦ Screw, $\geq \text{Ø } 4 \times 70$ mm, spacing ≤ 120 mm (or equivalent)
- ⑧ Promat K84 glue
- ⑩ Steel anchors, $\geq \text{M8}$, ≥ 2 pieces per angle section