

European Technical Assessment

ETA 07/0008

Version 01

Date of issue: 2017-11-08



UBAtc Assessment Operator:
Belgian Construction Certification Association
Rue d'Arlon 53 - 1040 Brussels
www.bcca.be - info@bcca.be



Technical Assessment Body issuing the European Technical Assessment: UBAtc.
UBAtc has been designated according to Article 29 of Regulation (EU) No 305/2011
and is member of EOTA (European Organisation for Technical Assessment)

Trade name of the construction product:	CW 50-HV
Product family to which the construction product belongs:	9 - Structural sealant glazing kit for use in curtain walling
Manufacturer:	Reynaers Aluminium N.V. Oude Liersebaan 266, B-2570 Duffel Belgium
Manufacturing plant:	Reynaers Aluminium N.V. Oude Liersebaan 266, B-2570 Duffel Belgium
Website:	www.reynaers.com
This European Technical Assessment is issued in accordance with Regulation (EU) No 305/2011, on the basis of:	ETAG 002, edition 1999 amended in 2012, used as European Assessment Document (EAD)
This version replaces:	European Technical Approval 07/0008, issued on 9 November 2012
This European Technical Assessment contains:	30 pages, including 1 annex which forms an integral part of the document



European Organisation for Technical Assessment

Legal bases and general conditions

1. This European Technical Assessment is issued by UBAtc (Union belge pour l'Agrément technique de la construction, i.e. Belgian Union for technical Approval in construction), in accordance with:
 - Regulation (EU) N° 305/2011¹ of the European Parliament and of the Council of 9 March 2011 laying down harmonised conditions for the marketing of construction products and repealing Council Directive 89/106/EEC
 - Commission Implementing Regulation (EU) N° 1062/2013² of 30 October 2013 on the format of the European Technical Assessment for construction products
 - Guideline for European technical approval 002 (ETAG), used as European Assessment Document (EAD)
2. Under the provisions of Regulation (EU) No 305/2011, UBAtc is not authorized to check whether the provisions of this European Technical Assessment are met once the ETA has been issued.
3. The responsibility for the conformity of the performances of the products with this European Technical Assessment and the suitability of the products for the intended use remains with the holder of the European Technical Assessment.
4. Depending on the applicable Assessment and verification of constancy of performance (AVCP) system, (a) notified body(ies) may carry out third-party tasks in the process of assessment and verification of constancy of performance under this Regulation once the European Technical Assessment has been issued.
5. This European Technical Assessment allows the manufacturer of the construction product covered by this ETA to draw up a declaration of performance for the construction product.
6. CE marking should be affixed to all construction products for which the manufacturer has drawn up a declaration of performance.
7. This European Technical Assessment is not to be transferred to other manufacturers, agents of manufacturers, or manufacturing plants other than those indicated on page 1 of this European Technical Assessment.
8. The European Technical Assessment holder confirms to guarantee that the product(-s) to which this assessment relates, is/are produced and marketed in accordance with and comply with all applicable legal and regulatory provisions, including, without limitation, national and European legislation on the safety of products and services. The ETA-holder shall notify the UBAtc immediately in writing of any circumstance affecting the aforementioned guarantee. This assessment is issued under the condition that the aforementioned guarantee by the ETA-holder will be continuously observed.
9. According to Article 11(6) of Regulation (EU) N° 305/2011, when making a construction product available on the market, the manufacturer shall ensure that the product is accompanied by instructions and safety information in a language determined by the Member State concerned which can be easily understood by users. These instructions and safety information should fully correspond with the technical information about the product and its intended use which the manufacturer has submitted to the responsible Technical Assessment Body for the issuing of the European Technical Assessment.
10. Pursuant to Article 11(3) of Regulation (EU) N° 305/2011, manufacturers shall adequately take into account changes in the product-type and in the applicable harmonised technical specifications. Therefore, when the contents of the issued European Technical Assessment do not any longer correspond to the product-type, the manufacturer should refrain from using this European Technical Assessment as the basis for their declaration of performance.
11. All rights of exploitation in any form and by any means of this European Technical Assessment is reserved for UBAtc and the ETA-holder, subject to the provisions of the applicable UBAtc regulations.
12. Reproduction of this European Technical Assessment including transmission by electronic means shall be in full. However, partial reproduction can be made with the written consent of UBAtc. In this case partial reproduction has to be designated as such. Texts and drawings of advertising brochures shall not contradict or misuse the European Technical Assessment.
13. Subject to the application introduced, this European Technical Assessment is issued in English and may be issued by the UBAtc in its official languages. The translations correspond fully to the English reference version circulated in EOTA.
14. This European Technical Assessment, ETA 07/0008, was first issued on 8 November 2017 and replaces European Technical Approval, ETA 07/0008, issued on 9 November 2012.

¹ OJEU, L 88 of 2011/04/04

² OJEU, L 289 of 2013/10/31

Technical Provisions

1 Technical description of the product

1.1 Characteristics of the product

1.1.1 General

This ETA is being issued for the products specified on the cover page on the basis of agreed data/information, deposited with the UBAtc, which identifies the products that have been assessed and judged. Changes to the product/production process, which could result in the deposited data/information being incorrect, should be notified to the UBAtc before the changes are introduced. The UBAtc will decide whether or not such changes affect the ETA.

1.1.2 Structural sealant glazing kit

Structural sealant glazing kit (SSGS) in which the glazing infills are bonded all along the perimeter with a structural sealant to a metallic structural sealant support frame.

The CW 50-HV kit is of the type I or II in accordance with ETAG 002, Table 1.

1.2 Components of the kit

1.2.1 Structural sealants

Table 1 – Structural sealants

Glass on anodised aluminium		
Dow Corning	DC 993	ETA 01/0005
	DC 895	ETA 01/0005
Kömmerling	Ködiglaze S	ETA 08/0286
Sika	SG 500	ETA 03/0038
	SG 20	ETA 06/0090
Tremco	Proglaze II	ETA 05/0006
	VEC 90	ETA 05/0005
	VEC 99	ETA 05/0005
Outer structural edge seal of the insulating glass unit		
Dow coming	DC 3362	ETA 03/0003
Kömmerling	GD 920	ETA 08/0004
Sika	IG 25	ETA 05/0068

Generic and specific types of suitable substrates for adhesion to the structural sealant Dow Corning 993 and the Dow Coming 3362 are given in the ETA of the structural sealants

1.2.2 Structural sealant support frame

Frame profile : Figures 1.a and 1.b:

- Fixed frame for opening part: 034.1121.XX; 034.0155.XX
- Opening light profiles: 034.1122.XX; 034.1113.XX; 034.0156.XX + adaptor 034.1116.17

The structural sealant support frame is made out of aluminium alloy conform to this ETA, Table 2.

Table 2 - aluminium alloy - characteristics

Alloy	Metallurgic state	Mechanical characteristics
Designation		
EN 573-3	EN 515	EN 755-2
EN AW-6060	T66	

³ The EN project standard on glass calculation is limiting maximum pressure on glass of 1,50 MPa

The anodising of the structural adhesion surface adaptor profile 034.1116.17 is performed by the firm Alural (Be), Alcan (Fr), Effector (PL) and Final (PL).

Geometrical and weight characteristics:

- Wall thickness of the profiles: 1,6 to 2 mm, tolerances conforming to EN 12020 –1 and -2
- External dimensions of the profiles: (cf. fig. 1); tolerances: EN 12020 –1 and -2
- Nominal linear mass (tolerances: + 10 %; - 10 %)
- Inertia: axes: xx parallel to the glazing, yy perpendicular to the glazing.

Table 3 - Geometrical and weight characteristics:

Profiles	b_{xx} (mm ²)	b_{yy} (mm ²)	Linear mass. Kg/m.
034.1121.XX	351350	108590	1,281
034.1122.XX	108310	55980	1,033
034.1113.XX	119310	56880	1,093
034.0155.XX	587970	112870	1,455
034.0156.XX	289200	70840	1,331
Aluminium profile for bonding - adaptor			
034.1116.17	110	820	0,115

1.2.3 Profiles and complimentary accessories

1.2.3.1 Mechanical self-weight support (fig. 2)

The support of the glass relies on the use of setting blocks, which transfer the glass dead load to the mechanical self-weight support.

Those devices are calculable according to the standardised loading using conventional calculations based upon the strength of the material. Taking into account a safety factor on aluminium $\gamma_m = 1,1$; a maximum pressure on glass of 1 MPa and a maximum vertical displacement between the 2 glass panes of 1 mm, the bearing capacity of the devices is given in this ETA, clause 2.3.1.5.

Mechanical self-weight support: length 100 mm, fixed by 2 screws ref 051.5282, DIN 916 M4x8

Table 4 – Mechanical self-weight support

Articles	application	Articles	application
073.7290.39	Opening part	073.7291.39	Opening part

1.2.3.2 Retaining device (fig. 1)

The retaining devices are made of aluminium AW 6060 T66 according EN 755-2.

Retaining devices are means of retaining the glass to reduce danger in the event of sealant failure. The necessity of these accessories is to be evaluated in function of the safety specifications, of the situation of the building and of its working condition. Those devices are calculable according to the standardised loading using conventional calculations based upon the strength of material. Taking into account of a safety factor on aluminium $\gamma_m = 1,1$ and of a maximum pressure on glass of 1 MPa³, the bearing capacity of the devices is given on 2.3.1.6.

The retaining devices are the pieces 073.7280.39 and 073.7282.39

1.2.3.3 Anchorage of the structural sealant support frame on the façade structure (fig. 2)

The frame profiles 034.1121.XX and 034.0155.XX are fixed onto the main structure with the distance piece 073.5215.-- and the screw 052.5301.-- at 140 mm from the corners, and with an in between distance of maximum 700 mm. The frame is connected as well to the main structure via the insulation profile 034.1123.04 and the gasket 080.9318.04 or 080.9331.04 used like weather seal.

In order to avoid the possible deviations between the main structure and the frame profile, the gasket 080.9360.04 is used.

1.2.3.4 Other devices (Fig. 4)

Corner to crimp for the structural sealant support frame:
068.7562.00; 068.7571.00; 068.7560.00; 068.7561.00; 060.7722.--;
068.7563.00.

1.2.4 Insulating glass unit

The kit CW 50-HV is designed in such way that the IGU outer edge seal is a structural edge seal. The outer seal must be performed with the structural sealant mentioned in Table 1 with a minimum bite of 6 mm.

IGU's must conform to the ETAG 002, clause 5.0.

For each project, the IGU's manufacturer shall deliver to the façadier a technical dossier as described in ETAG 002, clause 8.3.2.4 (vi).

Dimensional tolerances on the IGU: ± 2 mm on the glass pane, special care shall be taken that the glass is always in contact with the settings blocks

1.2.5 Cleaning product

The cleaning product that has to be used to clean the façade is mentioned in the structural sealant ETA's.

Other products may be used provided they are assessed for conformity to ETAG 002, clause 5.2.3.3.

1.3 Accessories

1.3.1 Gaskets (Fig.5)

The gaskets are used to ensure the air and water tightness between the frame and the opening light and between the frame and the façade structure.

- 080.9522.04, 080.9523.04: EPDM to be used for compartmentalization
- 080.9444.04: EPDM gasket to insure air and water tightness between fixed profile and opening light profile
- 080.9318.04; 080.9331.04: EPDM weather seal gasket,
- 080.9810.04, 080.9815.04, 080.9740.04: EPDM weather seal gasket,
- 080.9360.04: EPDM seal, between fixed frame and curtain wall structure
- 080.9300.04; 080.9303.04: EPDM gasket used as a spacer on opening light profile for structural seal.
- 034.1123.04: PVC profile used to support the gaskets 080.9318.04 or 080.9331.04;
- 080.9805.04; 080.9808.04; 080.9809.04 - EPDM gaskets used for air and water tightness. Those are installed into the PVC profile 034.1123.04 and are depending on the double glazing thickness

1.3.2 Iron work (fig. 8)

Friction stays Top hung window:

TH1: Reynaers 021.5640- 021.5650 - 021.5660: manufactured by Bezault Italinox 400R – 500R – 600R

TH2: Reynaers 021.5640- 021.5650 - 021.5660: manufactured by Bezault Italinox 400R – 500R – 600R and Reynaers 060.8370.– manufactured by Securistyle SPT26 with adjustment piece S7280.

For the Parallel Opening window the following friction stays are used:

POW: Reynaers 060.8360.--; 060.8361.--; 060.8362.--; 060.8363.--; 060.8364.--; 060.8365.-- manufactured by Securistyle PX 0450 RH; PX 0450 LH; PX 0670 RH; PX 0670 LH; PX 0950 RH; PX 0950 LH.

1.3.3 Setting and location blocks

The glazing dead load is transferred via the setting blocks.

Characteristics of the setting block:

Material: Silicone hardness SHORE D: 60 to 65, reference Coly-Pro, length to be adapted as a function of load

2 Specification of the intended use(s) in accordance with the applicable EAD

2.1 General

Structural sealant glazing kit (SSGS) for use as a façade or parts thereof. The structural sealant support frame consists of opening light frame profiles held in a fixed frame by ironwork which is anchored to the façade structure by means of screws to form a curtain walling. The façade structure is not a part of the present ETA.

The system is intended to be used in curtain walling for which requirements ER2 Safety in case of fire, ER3 Hygiene, health and environment, ER4 Safety in use, ER5 Protection against noise and ER6 Energy economy and heat retention may be fulfilled. The failure of the structural bond would cause risk to human life and/or considerable economic consequences.

The provisions made in this European Technical Assessment are based on the assumed working life of the SSGS of 25 years. The assumed working life of a system cannot be taken as a guarantee given by the producer, but are to be used as a means for selecting appropriate products.

2.2 Provisions related to manufacturing, packaging and storage

2.2.1 Storage of the anodised Glazing profile adaptor 034.1116.17.

The storage of the glazing profile adaptor has to be performed in a protected and maintained location with a maximum relative humidity of 60%. At those conditions, they can be used for projects up to 6 months after the anodising. After 6 months storage, the adaptor shall be re-evaluated according ETAG 002.

2.2.2 Structural sealant support frames (fig. 6)

The structural sealant support frames are manufactured by the façadiers according to the ETA designer rules and instructions

The structural sealant support frame profiles are made of extruded aluminium.

The profiles are assembled by corners to screw and/or to clamp to form the structural sealant support frame:

The dimensional tolerances on the structural sealant support frame are ± 1 mm.

Principal operations:

- Assembling of the structural seal support frame profile,
- Drilling and punching of the holes for ironwork, drainage and ventilation
- Setting the ironwork.

2.2.3 Bonding of the glazing

2.2.3.1 Combination sealant/anodising fit for use

The following combinations of anodizing/sealant has been assessed fit for use

Table 5 – Sealant-anodizing combinations

Sealants	Anodizing	Sealants	Anodizing
DC 993	Alural	VEC 99	Alcan
	Effector		Alural
	Final		Alcan
DC 895	Alcan	VEC 90	Alcan
	Alural		Alural
SG500	Alural	Proglaze II	Alcan
	Alcan		Alural
SG20	Alural	Kodiglaze	Alural

The use of the primer is evaluated for each anodizing batch of adaptor profile which is tested for adhesion with the appropriate structural sealant.

2.2.3.2 Application of the sealants

This work is performed in a workshop heated and maintained free from dust. Instructions given in the ETA for structural sealant are to be respected.

Principal stages of assembly:

- Preparation of the structural sealant adhesion surfaces as prescribed by the ETA on the structural sealant(s) used,
- Setting in place of the spacers,
- Setting in place of the glazing,
- Setting of setting blocks in place,
- Extrusion of the sealant,
- Pressing and smoothing the sealants beads,
- Setting of the mechanical self-weight support

The frame is immediately set on a rack. The sealant curing is then allowed without any movement between the glass and the structural support frame during the time specified in the structural sealant ETA

2.3 Provisions related to the design and use of the product

2.3.1 Design rules

2.3.1.1 Structural seals design

The structural seal shall be calculated as per annex 2 of the ETAG 002 with the design value given in the chapter 2.1.1 respecting the following the minimum dimensions of the structural seal are $e \geq 6$ mm, $h_c \geq 6$ mm. (For the definition of e , h_c , r , see ETAG 002).

Alternative calculation methods mentioned in the ETA of the structural sealants may also be used (see this ETA, clause 1.2.1).

2.3.1.2 Drainage and ventilation (Fig.7)

Drainage of the opening parts TH1, TH2 and POW is performed by cutting away the lips of the sealing gasket (080.9318.04 or 080.9331.04) over the length of the glass supports and on a length of 25 mm each 800 mm.

2.3.1.3 Weather sealing

The weather sealing is achieved with 2 seal gaskets 080.9444.04 in between the frame and vent. The gaskets 080.9318.04 or 080.9331.04 are used between the glass panel and the façade structure.

2.3.1.4 Maximum dimensions (Fig. 8)

Opening lights: The maximum dimensions of the opening part have been determined as a result of the test on façade prototype.

Table 6 – Maximum dimensions

Type of opening	Maximum dimensions wxh [m]
Top Hung window TH1	1,75 m x 1,75 m
Top Hung window TH2	1,35 m x 2,5 m
Parallel opening window POW	1,283m x 2,083 m

2.3.1.5 Transfer of the infill loading on the building structure

The transfer of the infill panel weight onto the building structure is done by the self-weight support 073.7290.39 and 073.7291.39. Those are fixed in the opening vent as described in clause 1.2.3.1.

Table 7 – Self weight support - maximum bearing capacity

Self-weight support	Maximum bearing capacity N
073.7290.39, length 100 mm (IGU)	1500
073.7291.39, length 100 mm (IGU)	1200

2.3.1.6 Retaining devices

The retaining devices are 073.7280.39 and 073.7282.39, see clause 1.2.3.2

Table 8 - Retaining device - maximum bearing capacity

Retaining devices 100 mm	Bearing capacity F_{des} (N)	Retaining devices 100 mm	Bearing capacity F_{des} (N)
073.7280.39	440	073.7282.39	440

Calculation of the length must be done project per project in function of the wind and the infill panel dimensions.

2.3.1.7 Ironwork

As a function of the glazed element size, the number of locks of the ironwork is given on fig.8.

2.3.2 Installation - Specifications on the façade structure

The maximum permissible deflection of the mullion and transom under the designed load is 1/200 (SLS)

The coupling between mullions and transoms is performed by mechanical T-connection.

The façade structure shall be electrically earthed.

The façade structure shall be equipped with expansion joints and movement joints in function of those of the building structure.

In the façade design, movement in the joint must not be thwarted and care shall be taken not to shortcut any façade structure joint with structural sealant support frames.

The structural sealant support frames are placed in the façade structure element per element.

The elements are then equipped with the gaskets.

Care shall be taken to allow drainage and ventilation.

2.3.3 Maintenance and repair**2.3.3.1 Repair**

All damages noticed on a structural sealant must be repaired as follows:

- dismantling of the structural sealant support frame
- replacement by a new unit in reserve
- repair of the damaged unit in workshop following the procedure described in this ETA, clauses 2.2 and 2.3 after removing of the structural sealant.

2.3.3.2 Maintenance

When necessary, the cleaning product mentioned in the structural sealants ETAs referred in Table 1 can be used.

For any other cleaning product, the compatibility with the kit shall be assessed as required by the ETAG 002.

3 Performance of the product and references to the methods used for its assessment

3.1 General

The assessment of the fitness for use of the structural sealant for the intended use in relation to the requirements for safety in case of fire; safety in use; hygiene health and environment; energy economy and heat retention; in the sense of the Essential Requirements 2, 3, 4 and 6, has been made in accordance with ETAG 002.

Where the guideline allows for classifications and/or choice, the selection specified below has been made.

3.2 ER2 Safety in case of fire

3.2.1 Reaction to fire

No performance assessed

3.2.2 Resistance to fire

No performance assessed

3.3 ER3 Hygiene, health and environment

3.3.1 Air permeability

Table 9 – Air permeability

Type of opening	ETAG 002, clause 5.1.3.1.2 EN 12152 – EN 12207
Top Hung window TH1 - TH2	Class 4
Parallel opening window - POW	

3.3.2 Water tightness

Table 10 – Water tightness

Type of opening	ETAG 002, clause 5.1.3.1.2 EN 12154 – EN 12208
Top Hung window - TH1	E 1500
Top Hung window - TH2	Class 9A
Parallel opening window - POW	E 900

3.3.3 Dangerous substances

No performance assessed

3.4 ER4 Safety in use

3.4.1 Wind resistance:

Table 11 – Wind resistance

Type of opening	ETAG 002, clause 5.1.4.9 EN 12210
Top Hung window TH1	C4
Top Hung window TH2	
Parallel opening window - POW	C5

3.4.2 Impact test

- Top hung window TH1, and parallel opening windows (POW): No performance assessed
- Top hung window TH2 – IGU 44.2-12-44.2 Class 3 internal impact according to EN 13049
- Sill height: not relevant

3.4.3 Racking & torsion and operating forces

Table 12 – Racking & torsion and operating forces

Type of opening	EN 13115	
	Racking Torsion	Operating forces
Top Hung window - TH1	Class 3	Class 1
Top Hung window - TH2		
Parallel opening window - POW	Class 4	

3.4.4 Sill height:

Not relevant

3.4.5 Behaviour in fire

No performance assessed

3.5 ER5 Protection against noise:

No performance assessed

3.6 ER6 Energy economy and heat retention

3.6.1 Determination of thermal insulation and susceptibility of condensation:

- Aggregate test method
- No performance assessed through testing
- Calculation method: As a function of the design and the glazing chosen, thermal modelling of a SSGS can be undertaken with various computer software packages. To use the results of those programmes, it is necessary to ensure that they are at least two-dimensional and cover all the required parameters (EN ISO 13788).
- The commonly used values of the thermal conductivity (λ -value) of the materials used in the present SSGS kit are

Table 13 - Thermal conductivity (λ -value) of the components

Materials	λ -value (W/m K)	Materials	λ -value (W/m K)
Stainless steel	17	Silicone	0,35
Glass	1	Spacer PU foam	0,078
EPDM	0,25	Aluminium	160

Thermal modelling of CW50-HV has been done according to the European Standard EN ISO 10077-2 based on the assumption of the EN ISO 12631:2012, clause 6.2. The total width of the joint is 108 mm, considering an infill panel of 1,1 W/m²K

Table 14 – U-value of typical joints

Joint between	U-value (W/m ² K)	ψ (W/mK)	Infill panel U _g (W/m ² K)
Opening part TH1 (insulating glass + fixed element (IGU))	4,82 to 5,25	0,52 to 0,56	IGU 1,1
Opening part TH2 (insulating glass + fixed element (IGU))	4,79 to 5,23	0,51 to 0,56	IGU 1,1
Opening part POW (insulating glass + fixed element (IGU glass))	4,85 to 5,28	0,52 to 0,57	IGU 1,1

Condensation:

With an inside temperature of 20°C and outside temperature of 0°C, condensation will occur at the following relative humidity:

- For THW1: 67% on the profiles and 65% on the glass
- For THW2: 68% on the profiles and 68% on the glass
- For POW1: 67% on the profiles and 65% on the glass
- For POW2: 68% on the profiles and 68% on the glass

3.7 Durability

The durability of the fitness for use has been demonstrated as follows: All the specific aspects of durability have been covered under the headings above, more particularly ER4 Safety in use.

4 Assessment and verification of constancy of performance (AVCP) system applied, with reference to its legal base

In accordance with Regulation (EU) N° 305/2011, Article 65, Directive 89/106/EEC is repealed, but references to the repealed Directive shall be construed as references to the Regulation.

The systems of assessment and verification of constancy of performance specified by the European Commission detailed in EC Decision 96/582/EC⁴ are as follows:

- System 1 (without audit testing of samples) for SSG kits Type II and IV;
- System 2+ (first possibility, including certification of the factory production control (FPC) by an approved body on the basis of its continuous surveillance, assessment and assessment) for SSG kits Type I and III

The system(s) of assessment and verification of constancy of performance are shown in the following Table.

Table 15 – System(s) of assessment and verification of constancy of performance

Product(s)	Intended use(s)	Level(s) or class(es)	Assessment and verification of constancy of performance system(s)*
Structural sealant glazing kits type II and IV	External walls and roofs	none	1
Structural sealant glazing kits type I and III		none	2+

* See Annex V to Regulation (EU) N° 305/2011

In practice, the operation of systems 1 and 2+ will be very similar for SSG kits, for the following reasons:

- the results of assessment testing shall be used by notified bodies (cf. Regulation (EU), Annex V, clause 1.6)
- the nature of the product is such that testing of samples at the factory by the manufacturer will be required under the FPC arrangements.

⁴ Commission decision of 24/06/96, published in the EC Official Journal L254 of 08/10/96

5 Technical details necessary for the implementation of the AVCP system

5.1 Tasks for the ETA-holder

5.1.1 Factory production control (FPC)

5.1.1.1 General

The manufacturer shall establish, document and maintain a FPC system to ensure that the products placed on the market conform to the stated performance characteristics. The FPC system shall consist of procedures, regular inspections and tests and/or assessments and the use of the results to control raw and other incoming materials or components, equipment, the production process and the product.

A FPC system conforming with the requirements of EN ISO 9001, and made specific to the requirements of this ETA, is considered to satisfy the above requirements.

The results of inspections, tests or assessments requiring action shall be recorded, as shall any action taken. The action to be taken when control values or criteria are not met shall be recorded.

The ETA holder of the kit is responsible for setting up appropriate rules and instructions for façadiers and the bonding workshops (quality manual for kit assembling and bonding). The different actors are bound via contractual links with the ETA holder to respect the kit holder's rules and instructions which are an integral part of the FPC system

The contractual links and their contents are described in the document GNB-CPD SG05 "Route to CE-marking", August 2003.

5.1.1.2 Equipment

All weighing, measuring and testing equipment shall be calibrated and regularly inspected according to documented procedures, frequencies and criteria.

5.1.1.3 Raw materials and components

The specifications of all incoming raw materials and components shall be documented, as shall the inspection scheme for ensuring their conformity.

5.1.1.4 Non-conforming products

In the event of any non-conformity of any product, that product shall be placed into quarantine and action taken to rectify the cause of the non-conformity. Products may not subsequently be dispatched until the problem has been resolved.

5.1.1.5 Tests and frequencies

All the elements, requirements and provisions adopted by the manufacturer are documented in a systematic manner in the form of written policies and procedures. This production control system ensures that the product is in conformity with the European Technical Assessment (ETA).

This relates only to taking samples representative of the final product. In the context of SSGS the testing of "H" pieces, peel tests as part of FPC provides the necessary evidence.

5.2 Tasks for the Technical Assessment Body

5.2.1 Initial Type Testing

Assessment tests on the sealant have been conducted under the responsibility by the assessment body (UBA_{tc}) in accordance with ETAG 002, Chapter 5. The assessment body (UBA_{tc}) has assessed the results of these tests in accordance with ETAG 002, Chapter 6, as part of the ETA issuing procedure. The results of assessment testing shall be used by notified bodies (cf. Regulation (EU), Annex V, clause 1.6).

5.2.2 Assessment of the factory production control - Initial inspection and continuous surveillance

Assessment of the FPC is the responsibility of a notified body.

An assessment must be carried out on the required manufacturing steps of each manufacturing plant to demonstrate that the factory production control is in conformity with the ETA and any subsidiary information. This assessment is based on an initial inspection of the different manufacturing actors' plants. (Kit designer; façadier(-s) and bonding workshops)

Subsequently continuous surveillance of factory production control is necessary to ensure continuing conformity with the ETA. This continuous surveillance shall be in conformity with to ETAG 002, clause 8.3, at each identified manufacturing plant.

It is recommended that surveillance inspections should be conducted at least twice a year at each identified manufacturing plant.

6 Bibliography

ETAG 002 Structural sealant glazing kits Edition November 1999
1st amendment: October 2001 - 2nd amendment: November 2005 - 3rd amendment: May 2012.

EN 515 Aluminium and aluminium alloys. Wrought products. Temper designations

EN 573-3 Aluminium and aluminium alloys - Chemical composition and form of wrought products - Part 3: Chemical composition and form of products

EN 755-2 Aluminium and aluminium alloys - Extruded rod/bar, tube and profiles - Part 2: Mechanical properties

EN 12020-1 Aluminium and aluminium alloys - Extruded precision profiles in alloys EN AW-6060 and EN AW-6063 - Part 1: Technical conditions for inspection and delivery

EN 12020-2 Aluminium and aluminium alloys. Extruded precision profiles in alloys EN AW-6060 and EN AW-6063. Tolerances on dimensions and form

EN 12152 Curtain walling. Air permeability. Performance requirements and classification.

EN 12154 Curtain walling - Watertightness - Performance requirements and classification

EN 12207 Windows and doors - Air permeability - Classification

EN 12208 Windows and doors. Watertightness. Classification

EN 12210 Windows and doors - Resistance to wind load - Classification EN 13049 Windows - Soft and heavy body impact - Test method, safety requirements and classification

EN 13115 Windows - Classification of mechanical properties - Racking, torsion and operating forces

EN ISO 10077-2 Thermal performance of windows, doors and shutters. Calculation of thermal transmittance. Numerical method for frames

EN ISO 12631:2012 Thermal performance of curtain walling - Calculation of thermal transmittance

EN ISO 13788 Hygrothermal performance of building components and building elements. Internal surface temperature to avoid critical surface humidity and interstitial condensation. Calculation methods

UBATc asbl is a non-profit organization according to Belgian law. It is a Technical Assessment Body notified by the Belgian notifying authority, the Federal Public Services Economy, SMEs, Self-Employed and Energy, on 17 July 2013 in the framework of Regulation (EU) No 305/2011 of the European Parliament and of the Council of 9 March 2011 laying down harmonised conditions for the marketing of construction products and repealing Council Directive 89/106/EEC and is member of the European Organisation for Technical Assessment, EOTA (www.eota.eu).

This European Technical Assessment has been issued by UBATc asbl on the basis of the technical work carried out by the Assessment Operator, BCCA.

On behalf of UBATc asbl,



Peter Wouters,
Director

On behalf of the Assessment Operator, BCCA, responsible for the technical content of the ETA,



Benny De Blaere,
Director general

The most recent version of this European Technical Assessment may be consulted on the UBATc website (www.ubatc.be).

Annex I Figures

Frame: 034.1121.XX

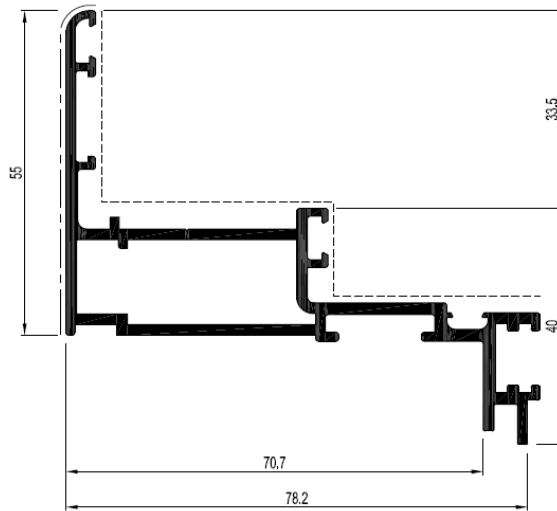

Vent: 034.1122.XX

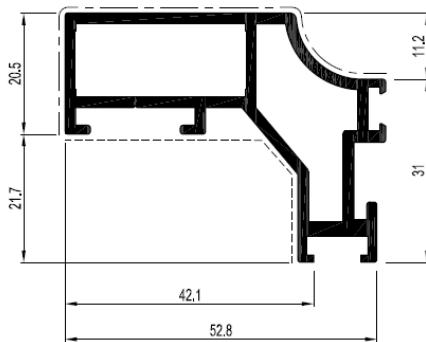

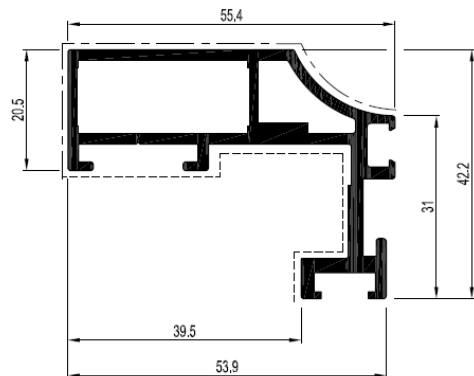

Vent: 034.1113.XX



Adaptor: 034.1116.17



Note: This is a work drawing of REYNAERS ALUMINIUM N.V. without any value, which can not be used for the development of any product.

	<p style="font-size: 1.2em; font-weight: bold;">WORKDRAWING</p> <p>Product name: CW 50-HV</p>	<p>Structural sealant support frame profiles</p>	<p>Cancelled — Replaces —</p>
<p>Scale for format A4 1:1</p>	<p>Designed MH</p>	<p>Date 05.01.2012</p>	
			<p>Drawing Name Figure 1 a</p>

Frame: 034.0155.XX

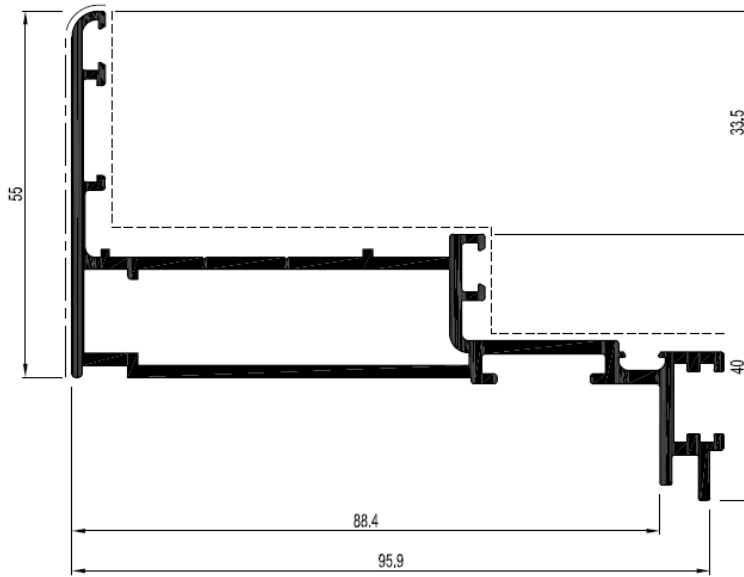

Vent: 034.0156.XX

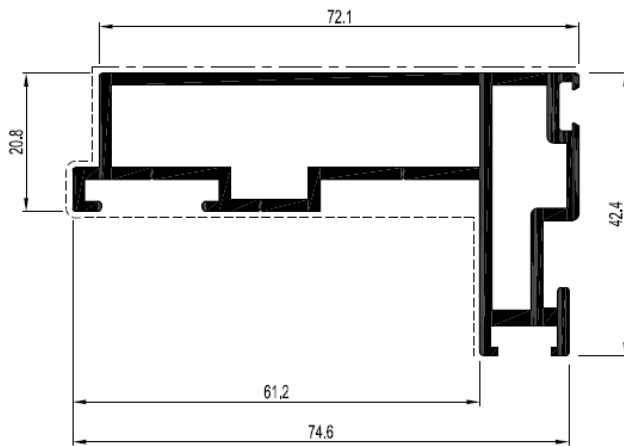

Adaptor: 034.1116.17



Note: This is a work drawing of REYNAERS ALUMINIUM N.V. without any value, which can not be used for the development of any product.

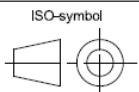

WORKDRAWING

Product name: CW 50-HV

Structural sealant support frame profiles

Cancelled

Replaces

Scale for format A4
1:1

Designed
MH

Date
05.01.2012



Drawing Name
Figure 1 b

073.7290.39

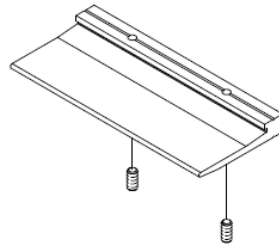
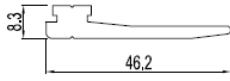

073.7291.39

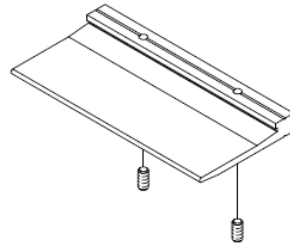
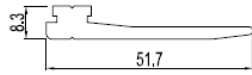

073.7280.39

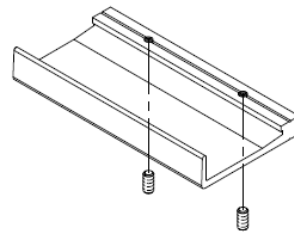
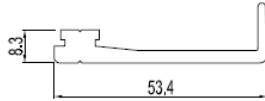

073.7282.39

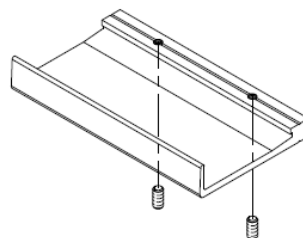
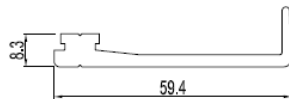

Note: This is a work drawing of REYNAERS ALUMINIUM N.V. without any value, which can not be used for the development of any product.

<p>ISO-symbol</p> 	<p>WORKDRAWING</p> <p>Product name: CW 50-HV</p>	<p>Mechanical self - weight supports and retaining devices</p>	<p>Cancelled</p> <p>—</p>
<p>Scale for format A4</p>			<p>Replaces</p> <p>—</p>
<p>Designed</p> <p>MH</p>	<p>Date</p> <p>06.01.2012</p>		<p>Drawing Name</p> <p>Figure 2</p>

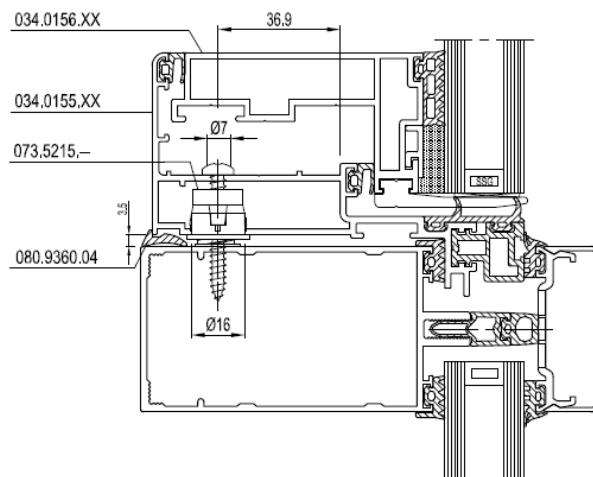
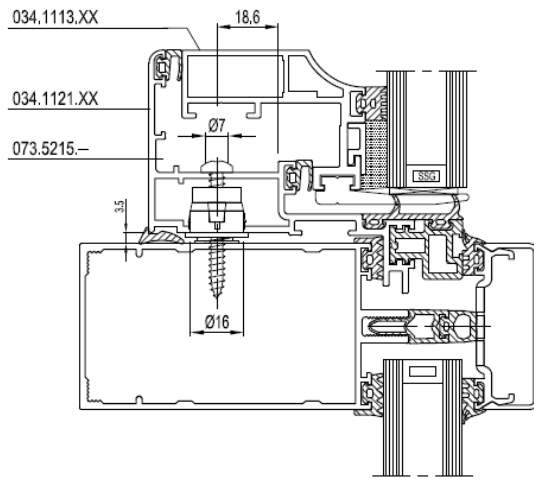
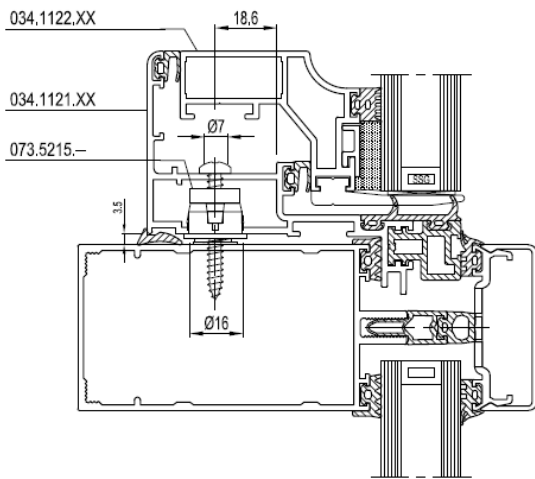
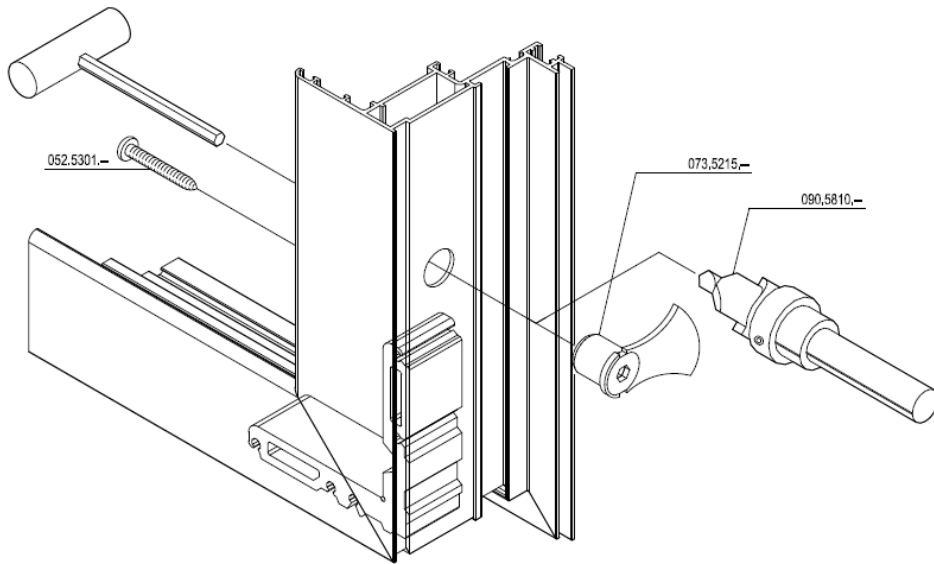

Note: This is a work drawing of REYNAERS ALUMINIUM N.V. without any value, which can not be used for the development of any product.

ISO-symbol 	WORKDRAWING Product name: CW 50-HV		Anchorage of the structural sealant support frame on the facade structure		Cancelled —
					Replaces —
Scale for format A4	Designed MH	Date 06.01.2012			Drawing Name Figure 3 a

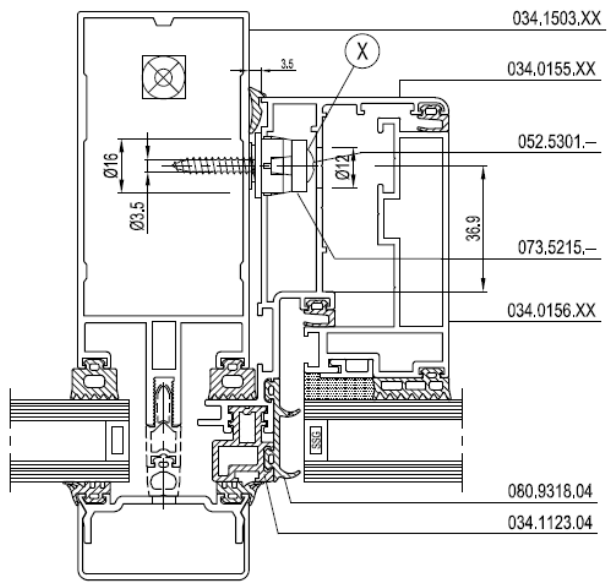
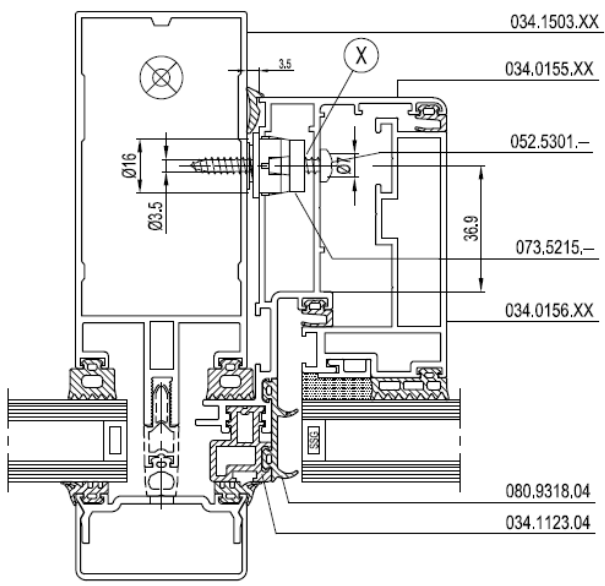

(X) SEALING AGENT

- X < 435mm with 021.5640.-
- X < 565mm with 021.5650.-
- X < 665mm with 021.5660.-
- X < 720mm with 060.8370.-

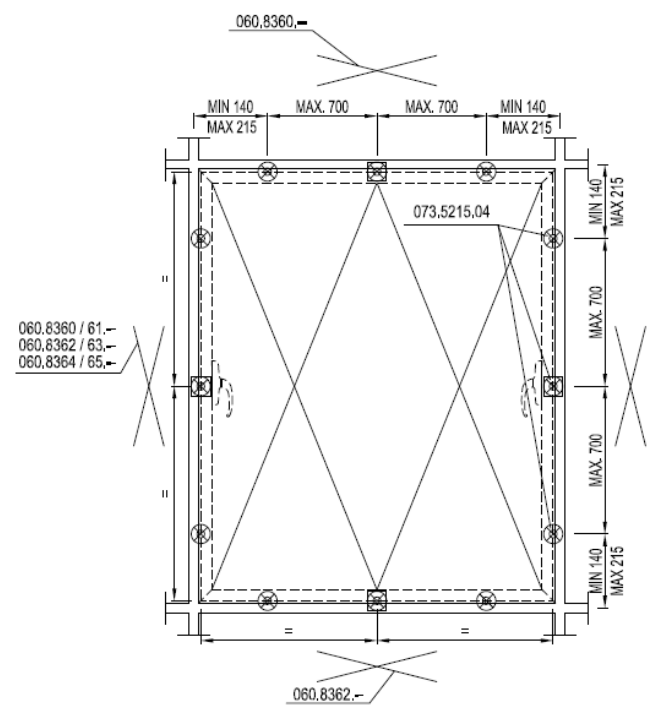
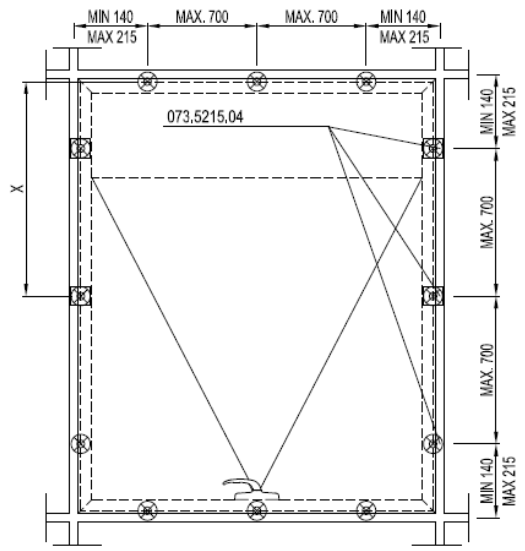

Note: This is a work drawing of REYNAERS ALUMINIUM N.V., without any value, which can not be used for the development of any product.

ISO-symbol 	<h1>WORKDRAWING</h1>		<h2>Anchorage of the structural sealant support frame on the facade structure</h2>	Cancelled
	Product name: CW 50-HV			Replaces
Scale for format A4	Designed MH	Date 09.01.2012		Drawing Name Figure 3 b

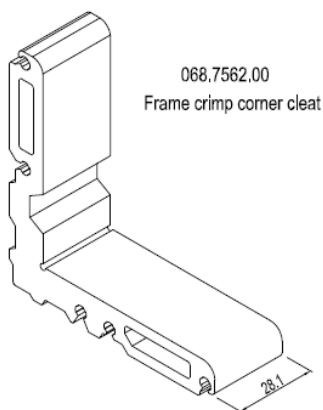

068.7562.00
Frame crimp corner cleat

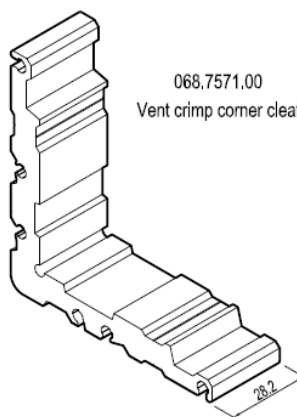

068.7571.00
Vent crimp corner cleat

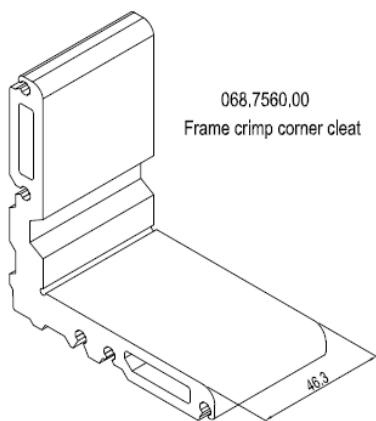

068.7560.00
Frame crimp corner cleat

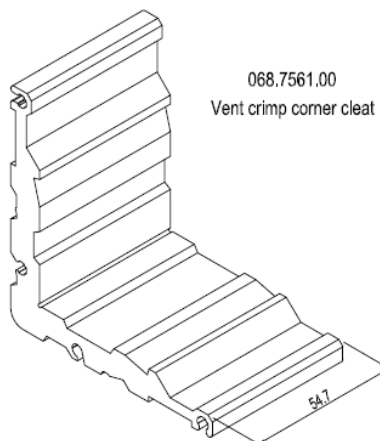

068.7561.00
Vent crimp corner cleat

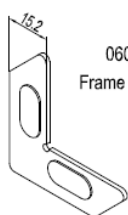

060.7722.-
Frame rebate support

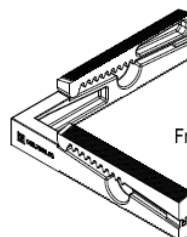

068.7563.00
Frame corner piece

Note: This is a work drawing of REYNAERS ALUMINIUM N.V. without any value, which can not be used for the development of any product.

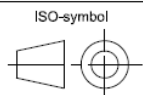

Scale for
format A4

WORKDRAWING

Product name: CW 50-HV

Designed
MH

Date
06.01.2012



Corner connections overview

Drawing Name
Figure 4 a

Cancelled
—
Replaces
—

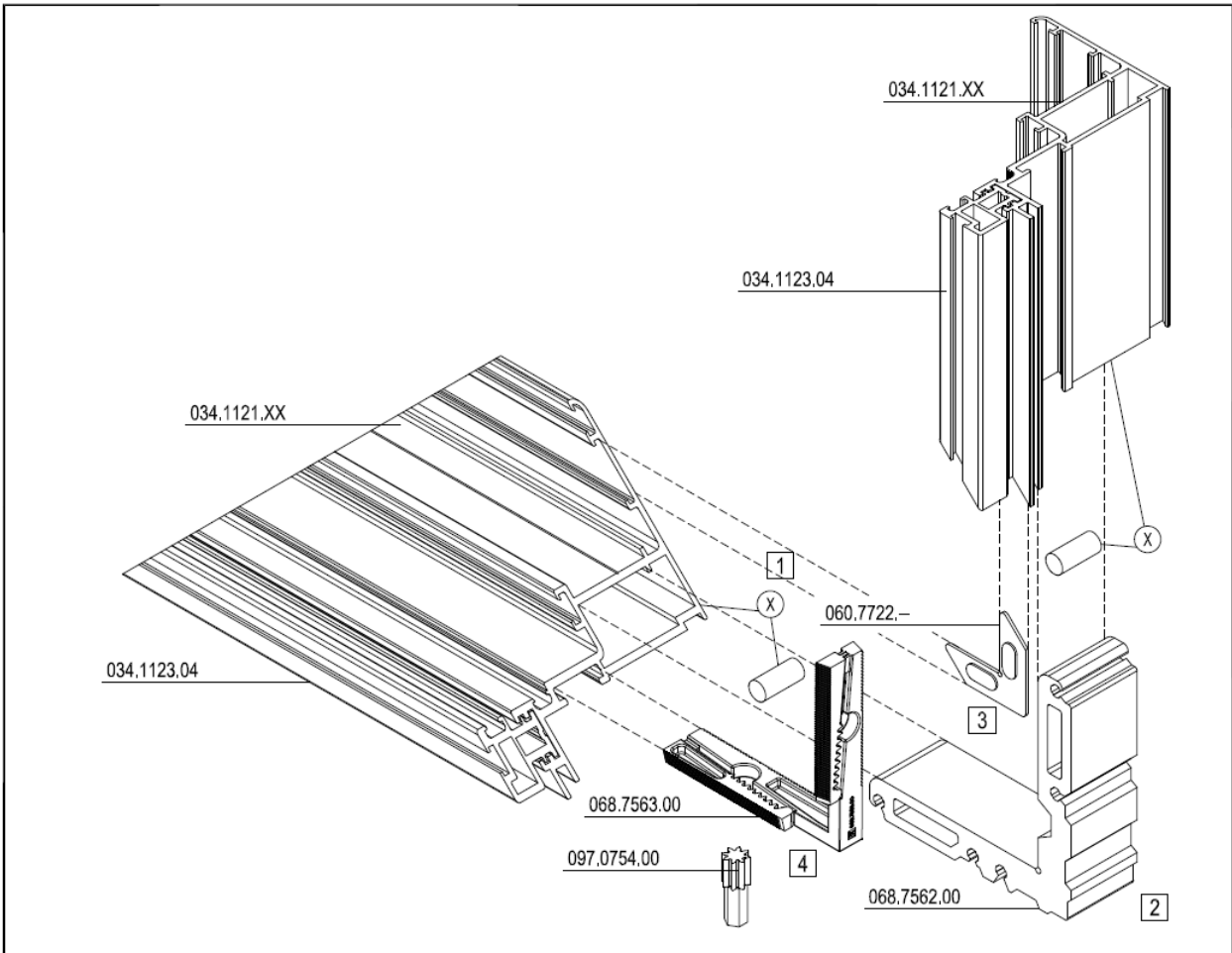

Assembly order 1 2 3 4

Sealing agent (X)

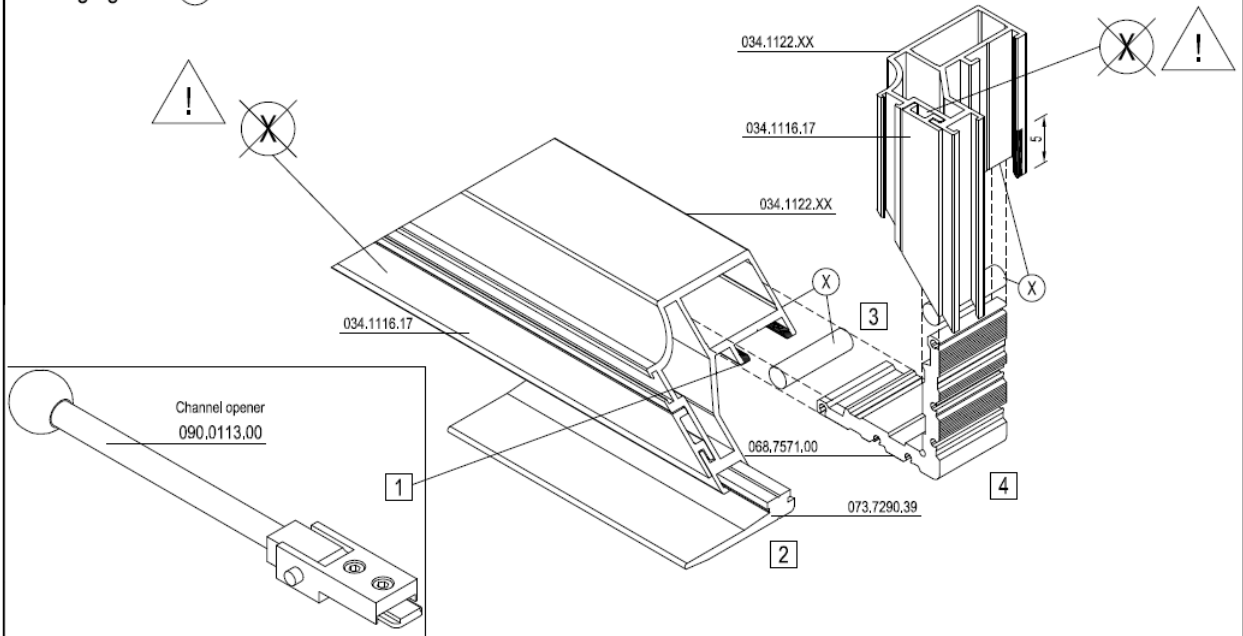

Note: This is a work drawing of REYNAERS ALUMINIUM N.V. without any value, which can not be used for the development of any product.

ISO-symbol 	<h1>WORKDRAWING</h1>		<h2>Corner assembly - principle</h2>	Cancelled —
	Product name: CW 50-HV			Replaces —
Scale for format A4	Designed MH	Date 06.01.2012		Drawing Name Figure 4 b

080.9810.04
EPDM seal gasket



080.9815.04
EPDM seal gasket



080.9740.04
EPDM seal gasket

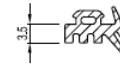

080.9522.04
Compartmentation gasket

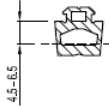

080.9523.04
Compartmentation gasket

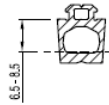

034.1123.04
Filling profile HPVC

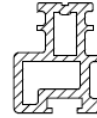

080.9805.04
EPDM butt strip

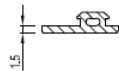

080.9808.04
EPDM butt strip

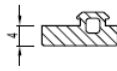

080.9809.04
EPDM butt strip



080.9318.04
EPDM weather seal gasket

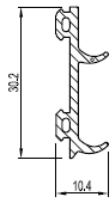

080.9331.04
EPDM weather seal gasket

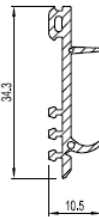

080.9444.04
EPDM weather seal gasket



080.9300.04
EPDM gasket (spacer)



080.9303.04
EPDM gasket (spacer)



080.9360.04
EPDM seal gasket



Note: This is a work drawing of REYNAERS ALUMINIUM N.V. without any value, which can not be used for the development of any product.

ISO-symbol 	WORKDRAWING Product name: CW 50-HV		EPDM gaskets		Cancelled —
	Scale for format A4	Designed MH	Date 06.01.2012		
			Drawing Name Figure 5		

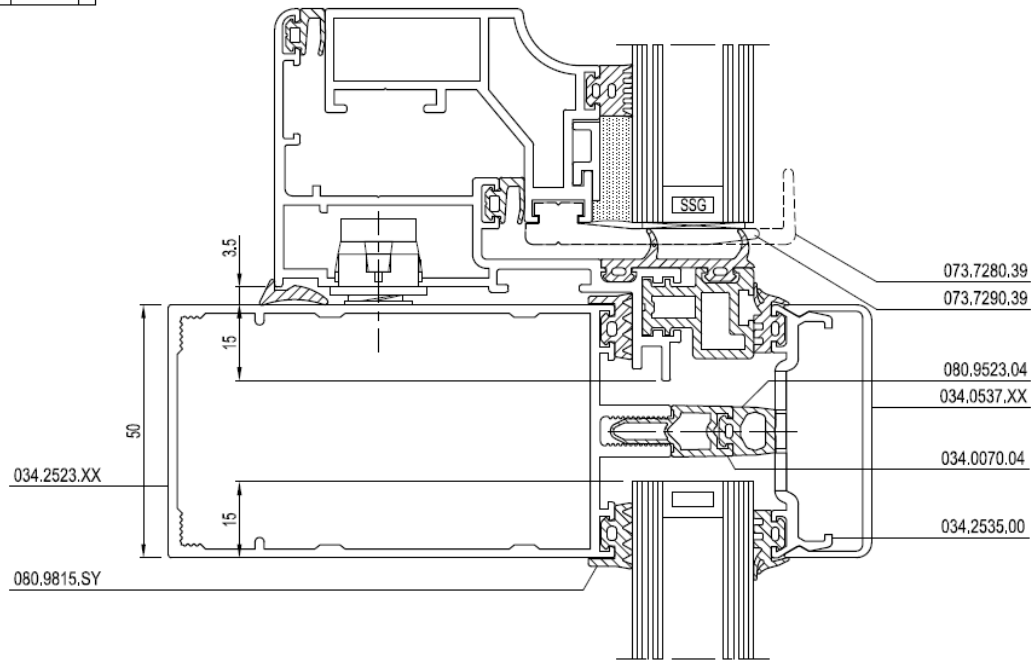
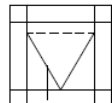
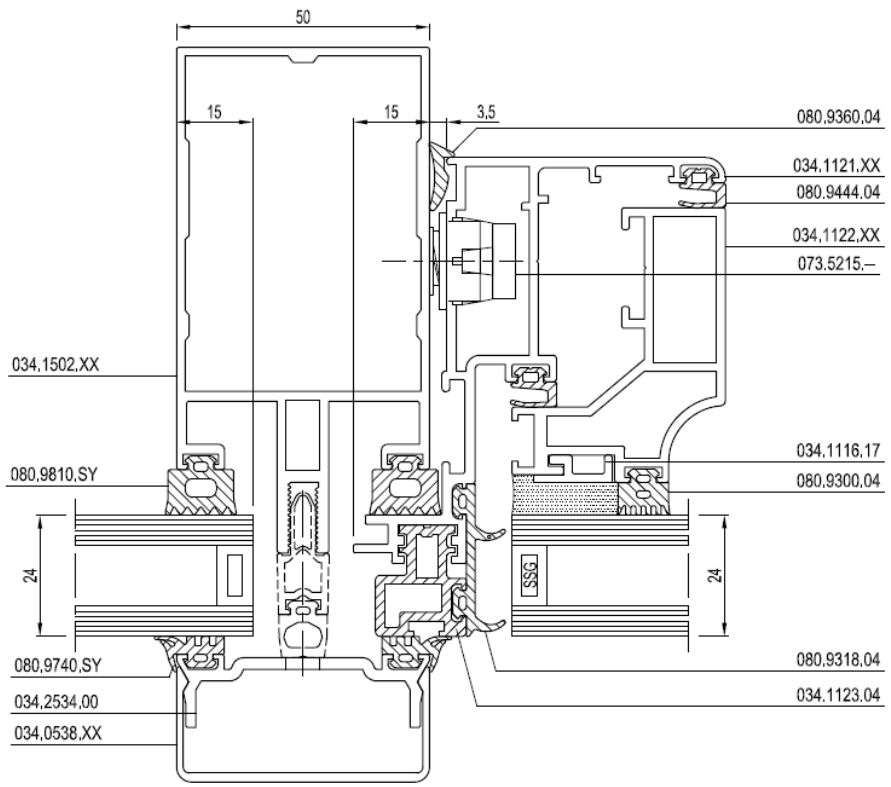

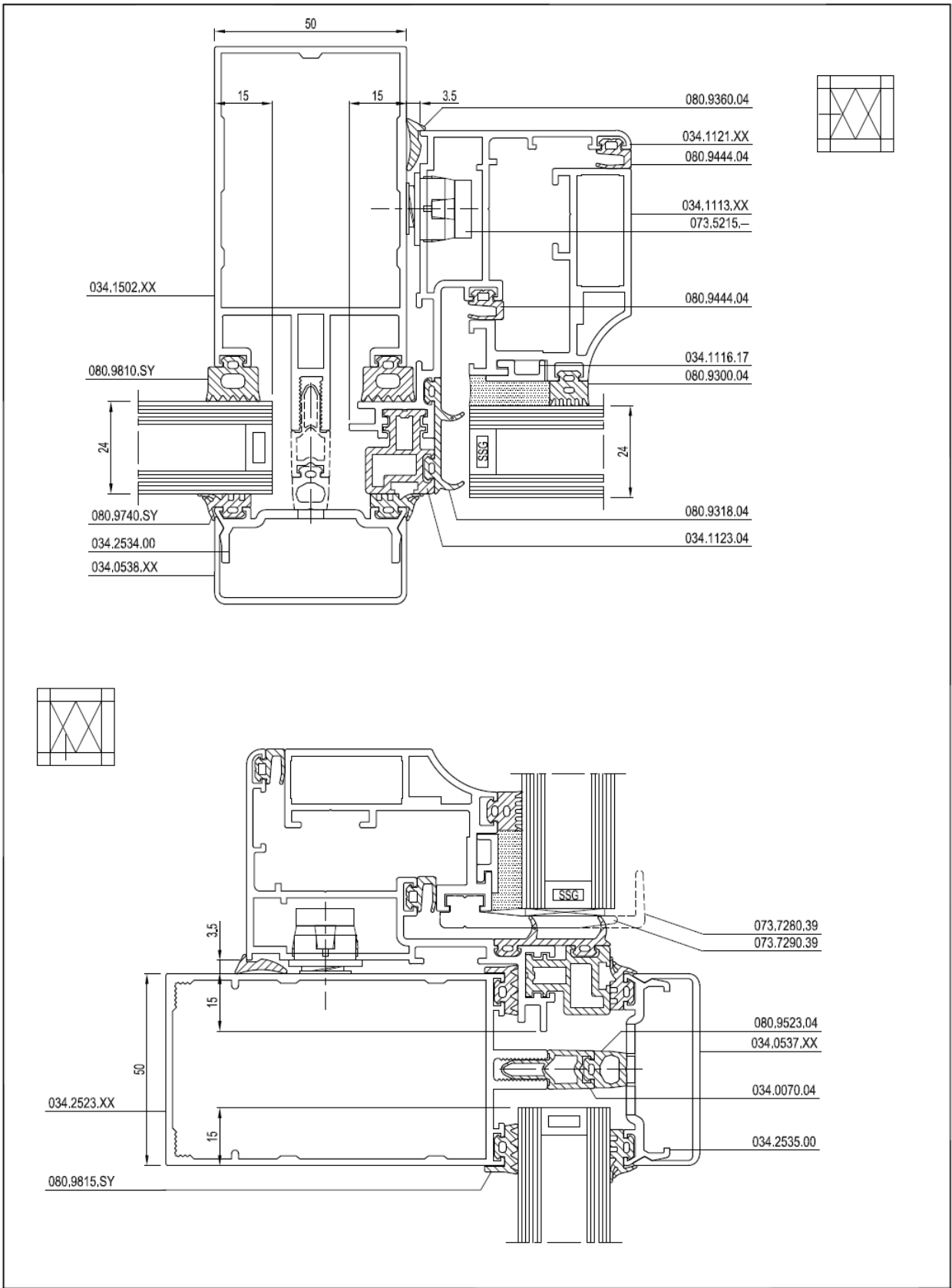

Note: This is a work drawing of REYNAERS ALUMINIUM N.V. without any value, which can not be used for the development of any product.

ISO-symbol 	WORKDRAWING Product name: CW 50-HV		Top Hung window with frame 034.1121.XX + vent 034.1122.XX		Cancelled —
					Replaces —
Scale for format A4	Designed MH	Date 06.01.2012			Drawing Name Figure 6 a

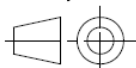

Note: This is a work drawing of REYNAERS ALUMINIUM N.V. without any value, which can not be used for the development of any product.

ISO-symbol 	WORKDRAWING Product name: CW 50-HV		Parellel opening window with frame 034.1121.XX + vent 034.1113.XX	Cancelled — Replaces —
	Scale for format A4	Designed MH	Date 06.01.2012	

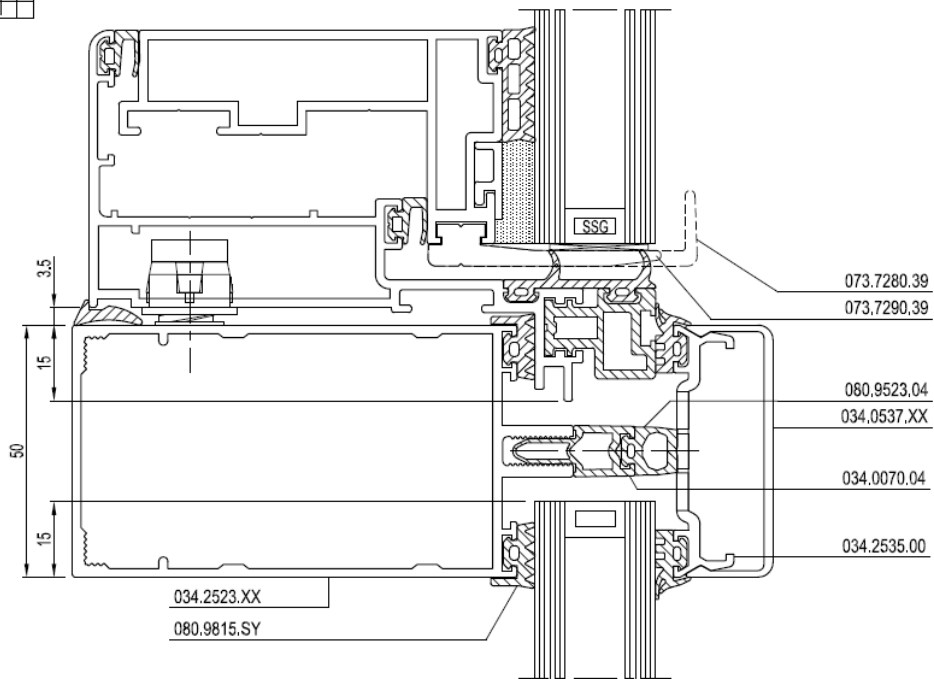
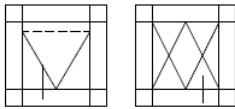
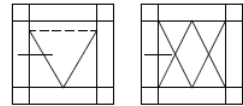
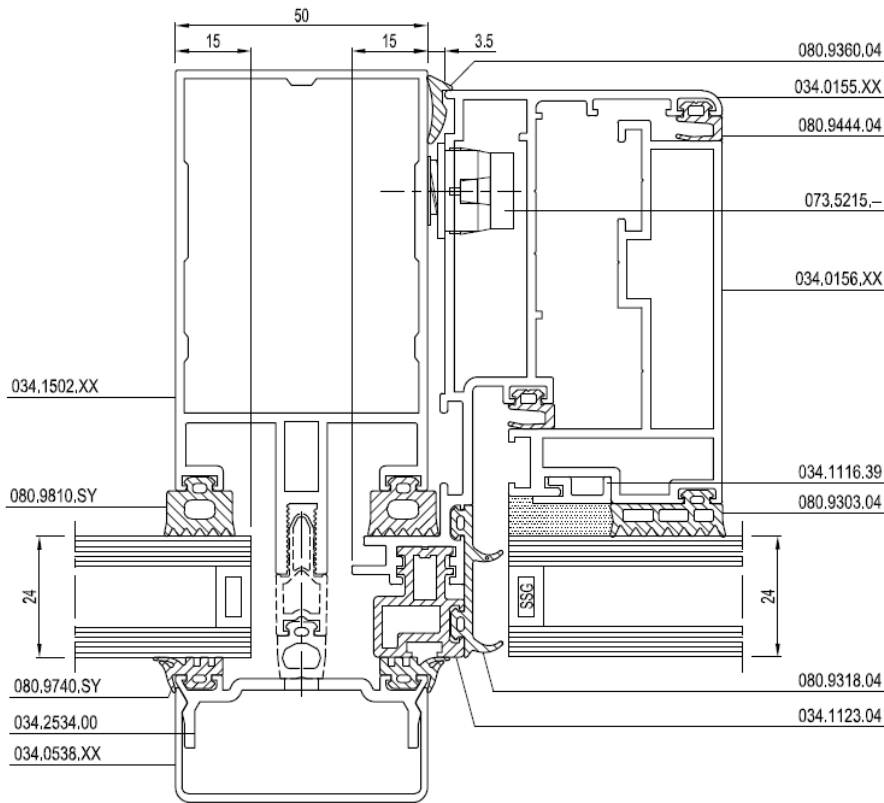

Note: This is a work drawing of REYNAERS ALUMINIUM N.V. without any value, which can not be used for the development of any product.

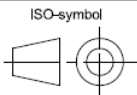

WORKDRAWING

Product name: CW 50-HV

Top hung window and Parellel opening window with frame 034.0155.XX + vent 034.0156.XX

Cancelled

Replaces

Scale for format A4

Designed

MH

Date

06.01.2012



REYNAERS

Drawing Name

Figure 6 c

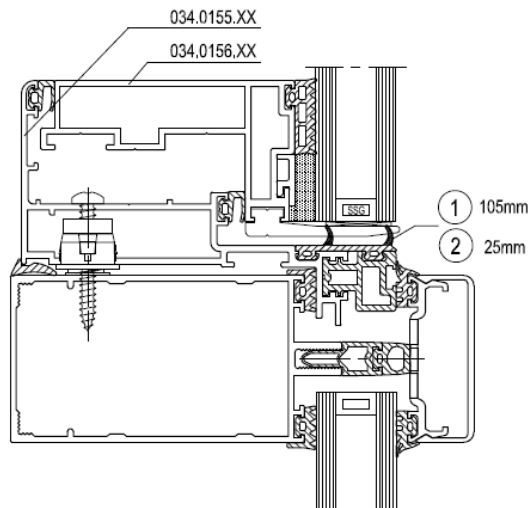
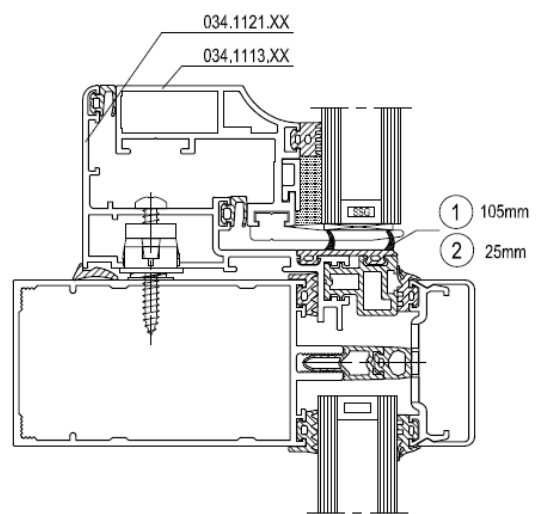
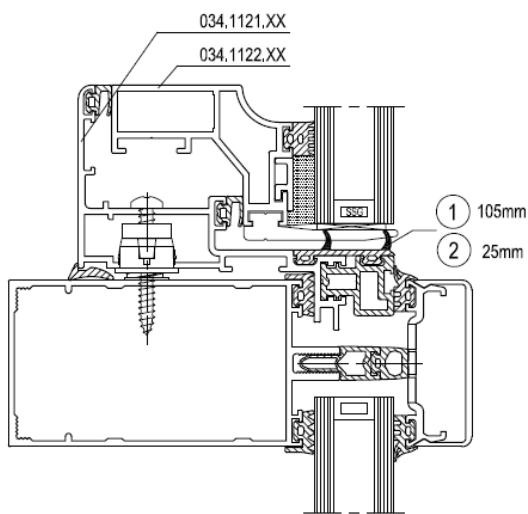
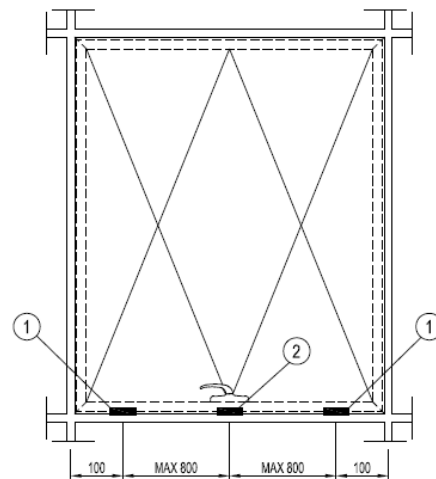
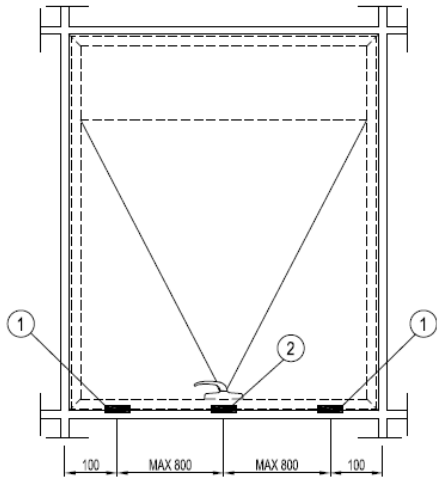

Note: This is a work drawing of REYNAERS ALUMINIUM N.V. without any value, which can not be used for the development of any product.

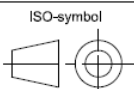

WORKDRAWING

Product name: CW 50-HV

Vent drainage

Cancelled

Replaces

Scale for format A4

Designed

MH

Date

06.01.2012



Drawing Name

Figure 7

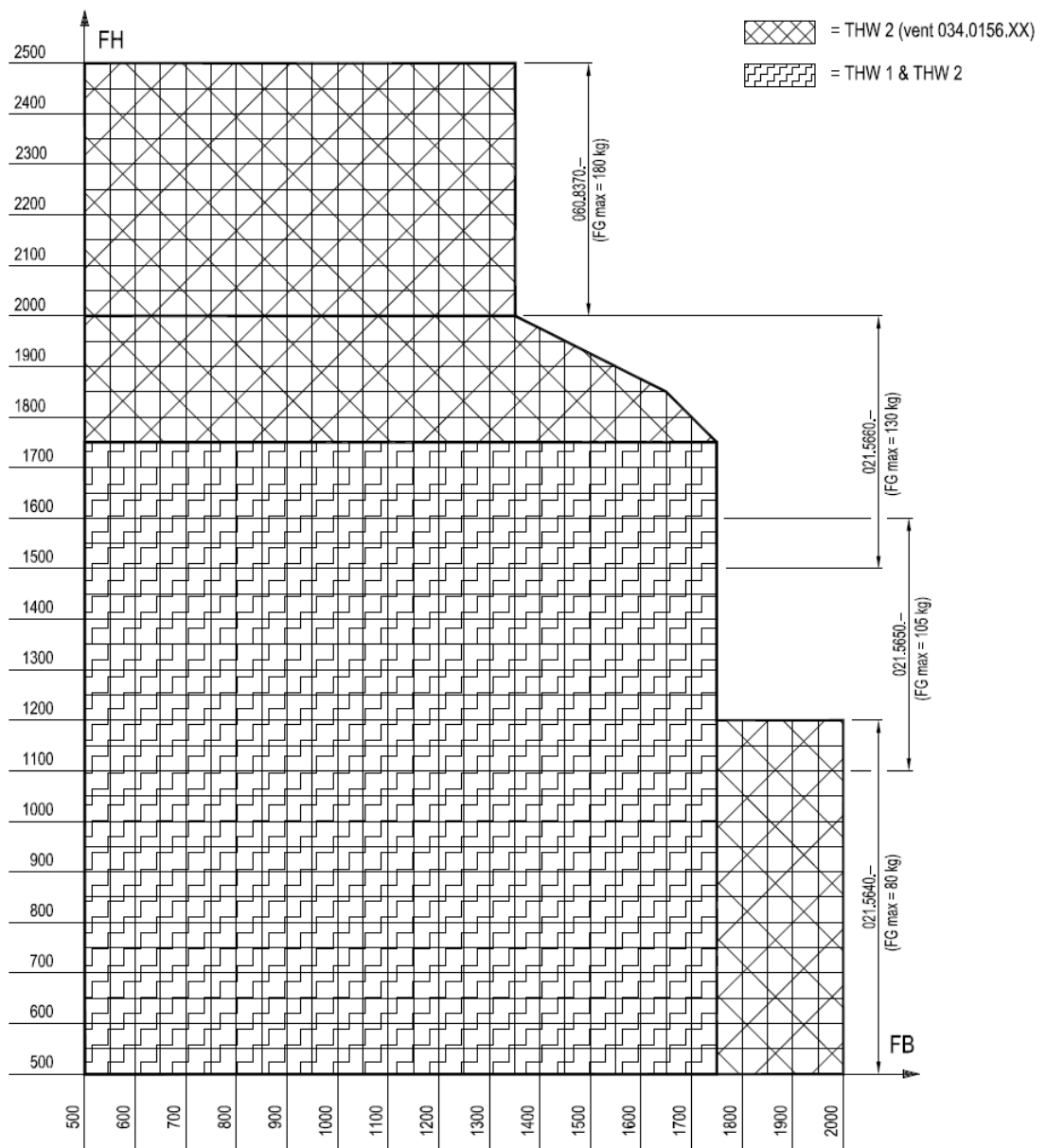
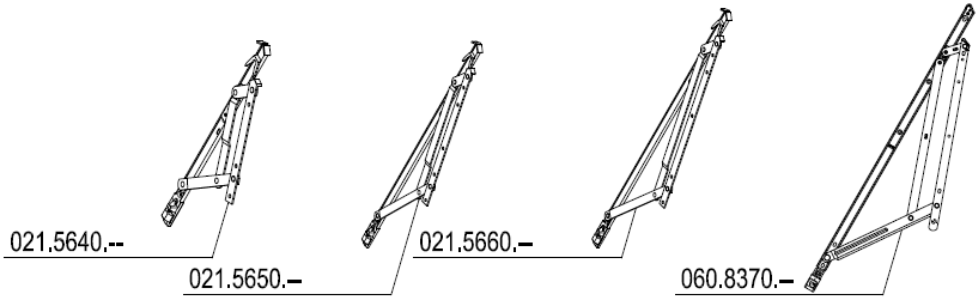

Note: This is a work drawing of REYNAERS ALUMINIUM N.V. without any value, which can not be used for the development of any product.

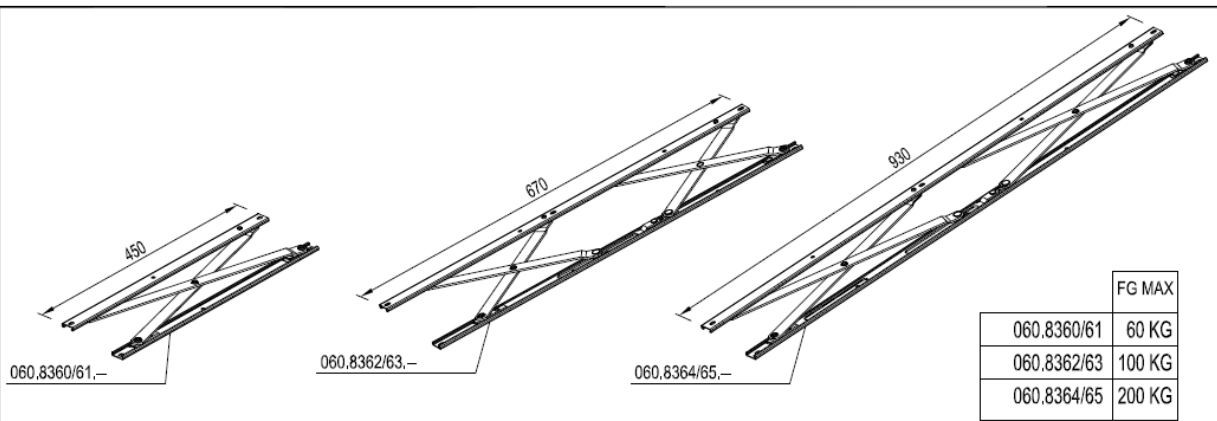

ISO-symbol 	WORKDRAWING Product name: CW 50-HV		Top Hung window maximum dimensions		Cancelled —
					Replaces —
Scale for format A4	Designed MH	Date 06.01.2012			Drawing Name Figure 8 a

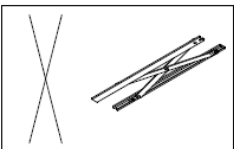
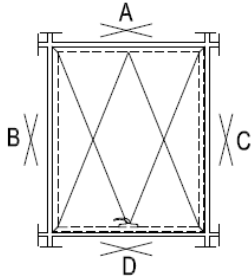
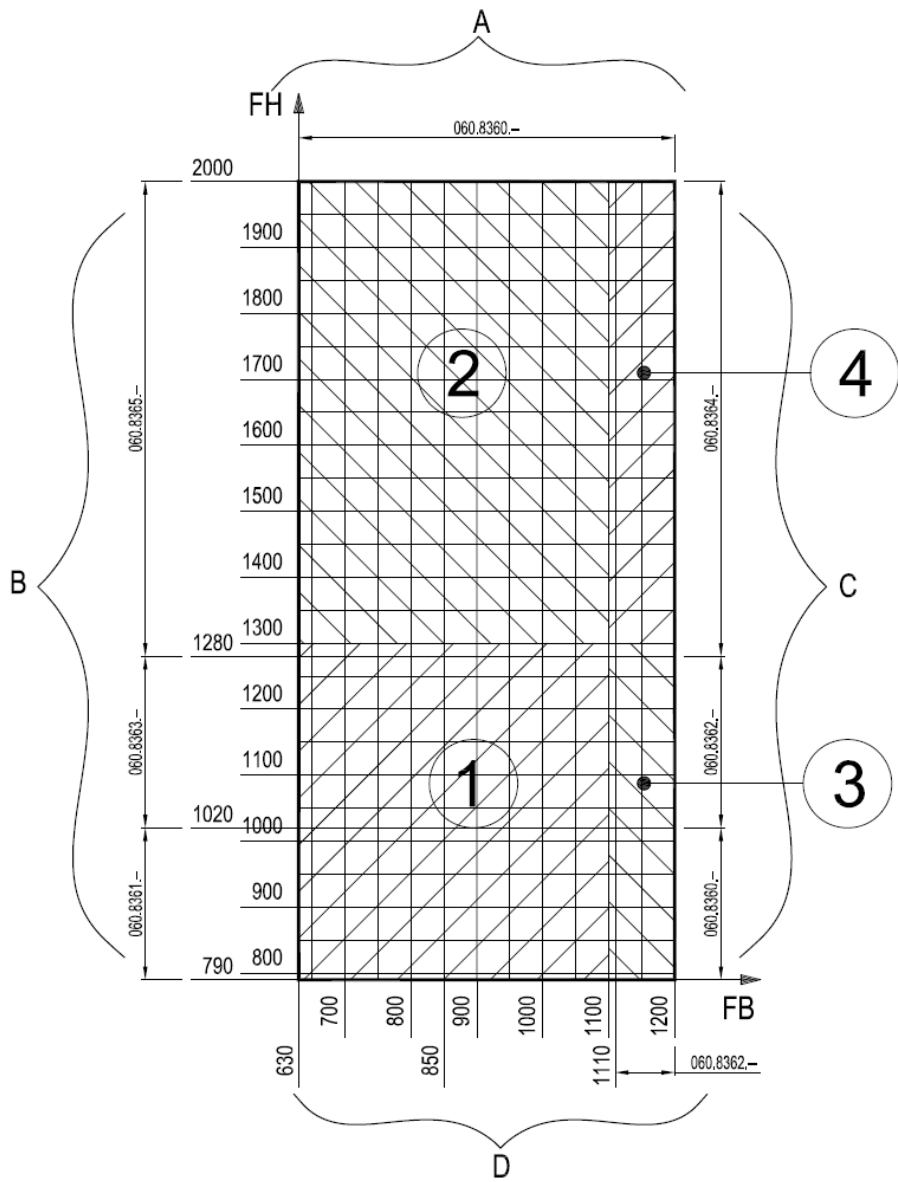

	FG MAX
060.8360/61	60 KG
060.8362/63	100 KG
060.8364/65	200 KG

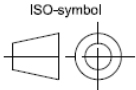

Note: This is a work drawing of REYNAERS ALUMINIUM N.V. without any value, which can not be used for the development of any product.

 Scale for format A4	WORKDRAWING Product name: CW 50-HV		Parallel Opening window maximum dimensions		Cancelled —
	Designed MH	Date 06.01.2012			Drawing Name Figure 8 b

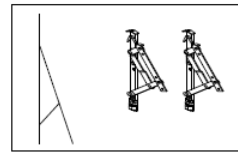
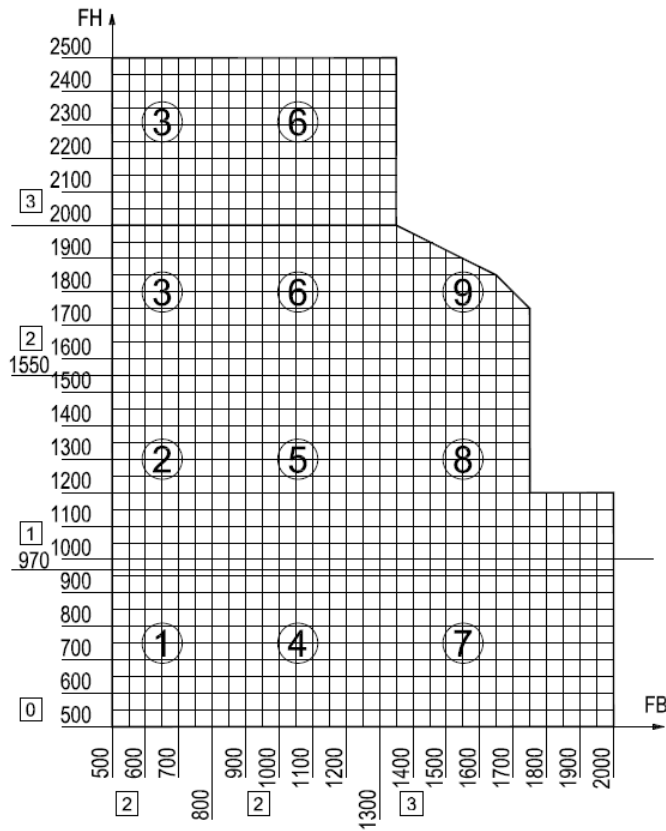

021.5640.-
021.5650.-
021.5660.-
060.8370.-

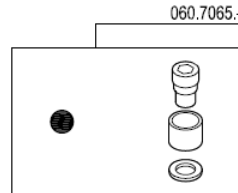

060.7065.-

Number of locking points 0 1 2 3

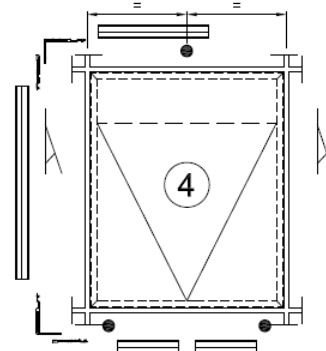
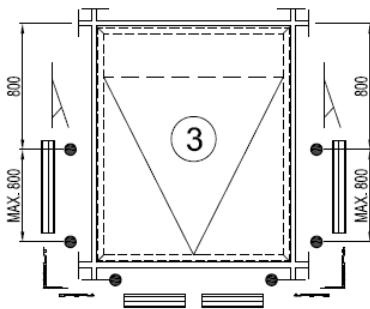
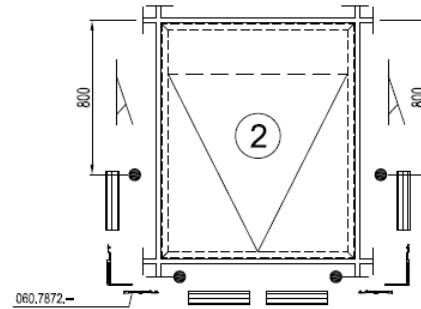
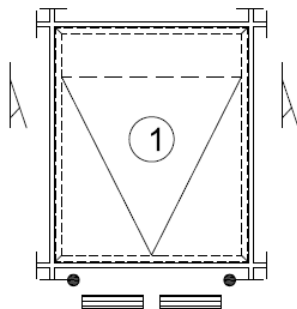

Note: This is a work drawing of REYNAERS ALUMINIUM N.V. without any value, which can not be used for the development of any product.

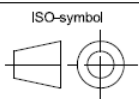

WORKDRAWING

Product name: CW 50-HV

Position and number of locking points

THW 2 (vent 034.0156.XX)

Cancelled

Replaces

Scale for format A4

Designed

MH

Date

06.01.2012

R REYNAERS

Drawing Name

Figure 8 d

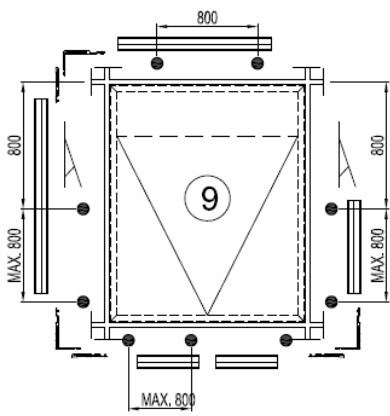
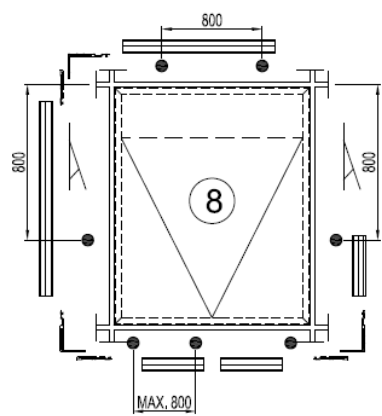
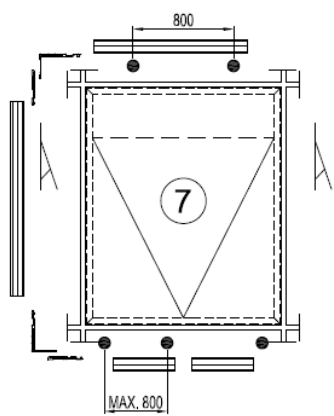
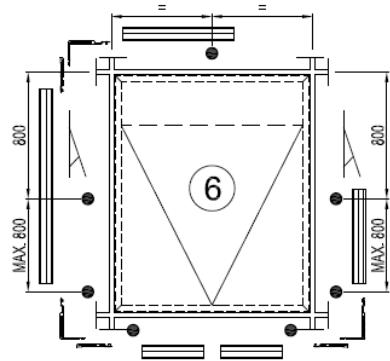
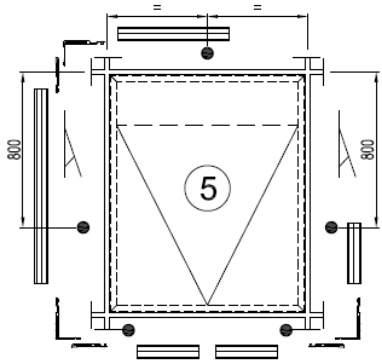

Note: This is a work drawing of REYNAERS ALUMINIUM N.V. without any value, which can not be used for the development of any product.

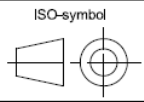

WORKDRAWING

Product name: CW 50-HV

Position and number of locking points
THW 2 (vent 034.0156.XX)

Cancelled
—
Replaces
—

Scale for
format A4

Designed
MH

Date
06.01.2012



Drawing Name
Figure 8 e

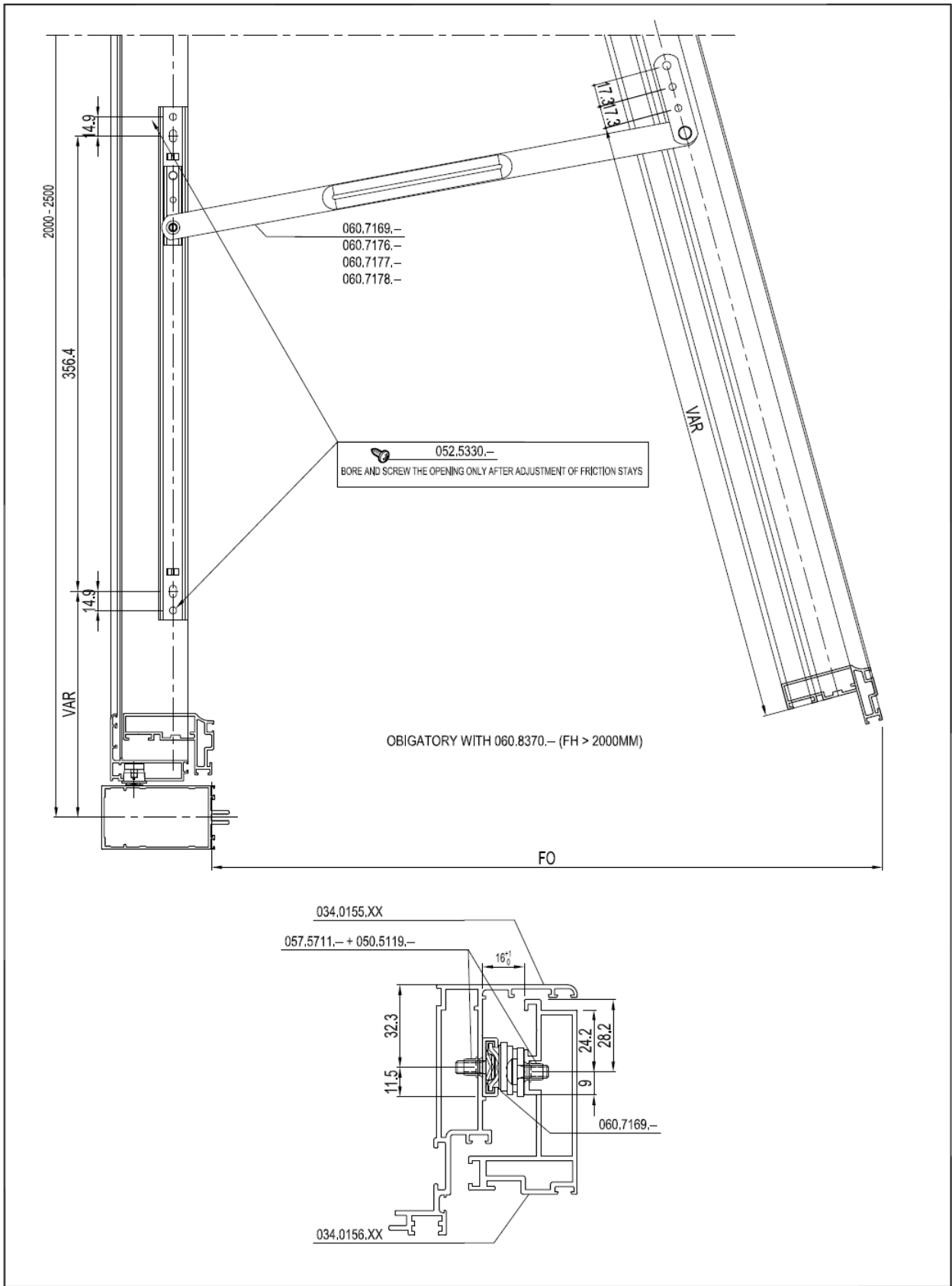

Note: This is a work drawing of REYNAERS ALUMINIUM N.V. without any value, which can not be used for the development of any product.

ISO-symbol 	WORKDRAWING Product name: CW 50-HV	Opening restrictor Top Hung window	Cancelled — Replaces —	
Scale for format A4	Designed MH	Date 06.01.2012		Drawing Name Figure 8 f

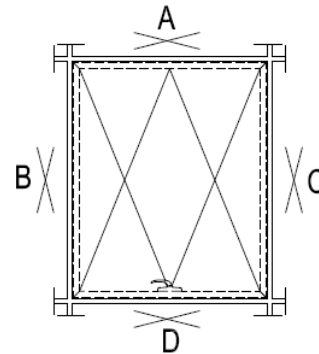
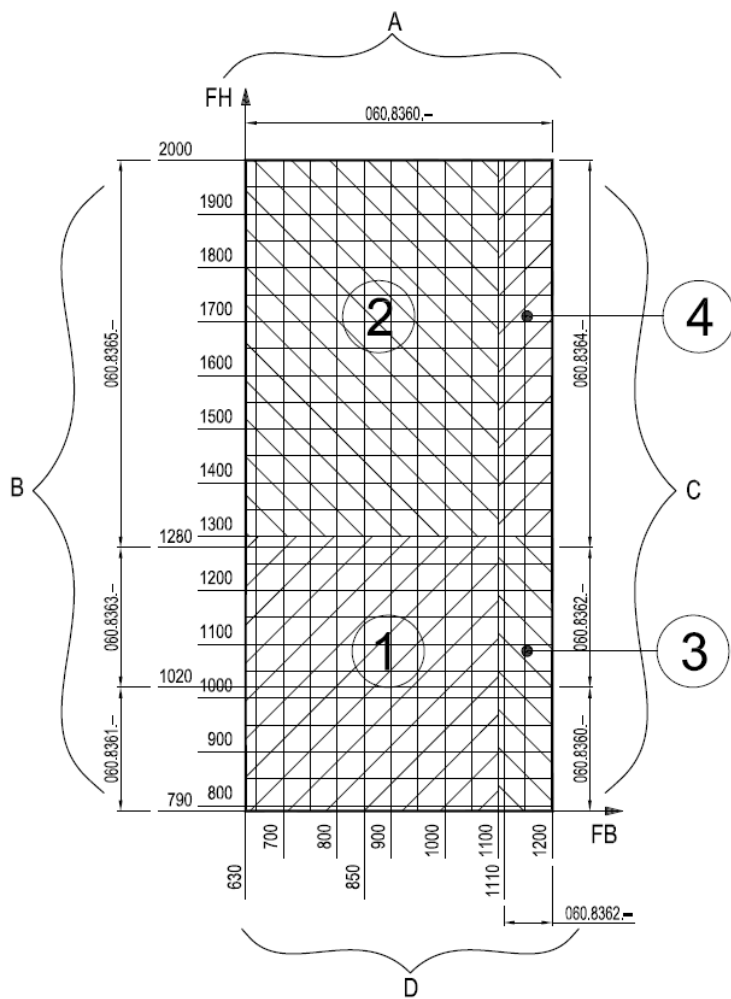

Note: This is a work drawing of REYNAERS ALUMINIUM N.V. without any value, which can not be used for the development of any product.

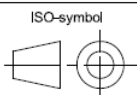

WORKDRAWING

Product name: CW 50-HV

Position and number of locking points
Parallel opening window

Cancelled
—
Replaces
—

Scale for
format A4

Designed
MH

Date
06.01.2012



Drawing Name
Figure 8 g

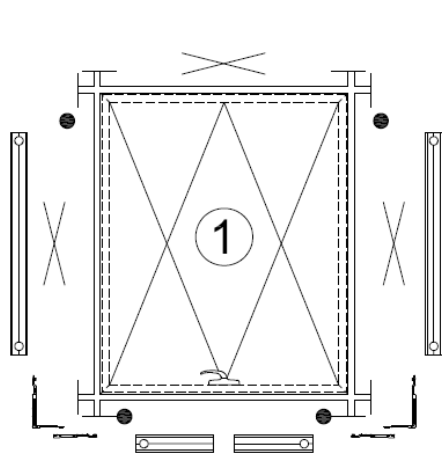

060.7872.-

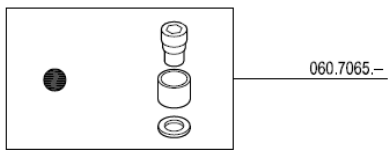
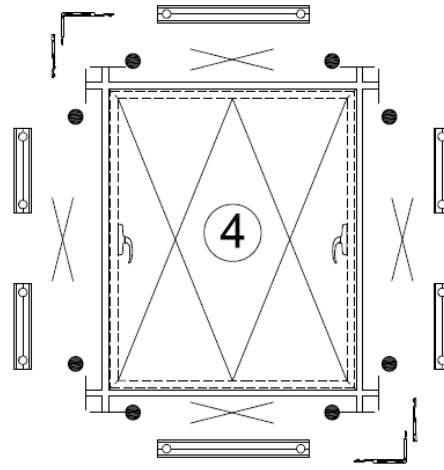
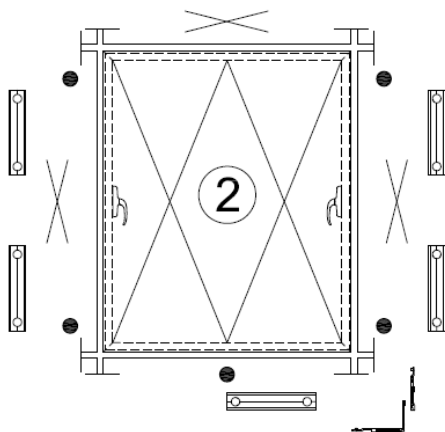
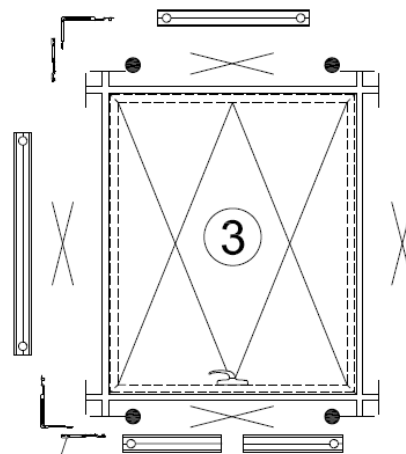

060.7065.-

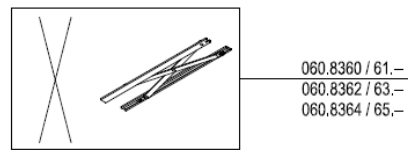

060.8360 / 61.-
060.8362 / 63.-
060.8364 / 65.-

Note: This is a work drawing of REYNAERS ALUMINIUM N.V. without any value, which can not be used for the development of any product.

	WORKDRAWING Product name: CW 50-HV		Position and number of locking points Parallel opening window	Cancelled — Replaces —
	Scale for format A4	Designed MH	Date 06.01.2012	