

European Technical Assessment

ETA 12/0551

Version 01

Date of issue: 2018-06-12



UBAtc Assessment Operator:
Belgian Construction Certification Association
Rue d'Arlon 53 - 1040 Brussels
www.bcca.be - info@bcca.be



Technical Assessment Body issuing the European Technical Assessment: UBAtc.
UBAtc has been designated according to Article 29 of Regulation (EU) No 305/2011
and is member of EOTA (European Organisation for Technical Assessment)

Trade name of the construction product:	WICTEC 50SG, WICLINE 90SG
Product family to which the construction product belongs:	9 - Structural sealant glazing kit for use in curtain walling
Manufacturer:	Sapa-Building-Systems GmbH Einsteinstrasse 61 89077 Ulm Germany
Manufacturing plant:	Sapa-Building-Systems GmbH Einsteinstrasse 61 89077 Ulm Germany
Website:	www.wicona.de
This European Technical Assessment is issued in accordance with Regulation (EU) No 305/2011, on the basis of:	ETAG 002, edition 1999 amended in 2012, used as European Assessment Document (EAD)
This version replaces:	European Technical Approval 12/0551, issued on 27 June 2013
This European Technical Assessment contains:	36 pages, including 13 Annexes (25 figures), which form an integral part of the document



European Organisation
for Technical Assessment

Legal bases and general conditions

1. This European Technical Assessment is issued by UBAtc (Union belge pour l'Agrément technique de la construction, i.e. Belgian Union for technical Approval in construction), in accordance with:
 - Regulation (EU) N° 305/2011¹ of the European Parliament and of the Council of 9 March 2011 laying down harmonised conditions for the marketing of construction products and repealing Council Directive 89/106/EEC
 - Commission Implementing Regulation (EU) N° 1062/2013² of 30 October 2013 on the format of the European Technical Assessment for construction products
 - Guideline for European technical approval 002 (ETAG), used as European Assessment Document (EAD)
2. Under the provisions of Regulation (EU) No 305/2011, UBAtc is not authorized to check whether the provisions of this European Technical Assessment are met once the ETA has been issued.
3. The responsibility for the conformity of the performances of the products with this European Technical Assessment and the suitability of the products for the intended use remains with the holder of the European Technical Assessment.
4. Depending on the applicable Assessment and verification of constancy of performance (AVCP) system, (a) notified body(ies) may carry out third-party tasks in the process of assessment and verification of constancy of performance under this Regulation once the European Technical Assessment has been issued.
5. This European Technical Assessment allows the manufacturer of the construction product covered by this ETA to draw up a declaration of performance for the construction product.
6. CE marking should be affixed to all construction products for which the manufacturer has drawn up a declaration of performance.
7. This European Technical Assessment is not to be transferred to other manufacturers, agents of manufacturers, or manufacturing plants other than those indicated on page 1 of this European Technical Assessment.
8. The European Technical Assessment holder confirms to guarantee that the product(-s) to which this assessment relates, is/are produced and marketed in accordance with and comply with all applicable legal and regulatory provisions, including, without limitation, national and European legislation on the safety of products and services. The ETA-holder shall notify the UBAtc immediately in writing of any circumstance affecting the aforementioned guarantee. This assessment is issued under the condition that the aforementioned guarantee by the ETA-holder will be continuously observed.
9. According to Article 11(6) of Regulation (EU) N° 305/2011, when making a construction product available on the market, the manufacturer shall ensure that the product is accompanied by instructions and safety information in a language determined by the Member State concerned which can be easily understood by users. These instructions and safety information should fully correspond with the technical information about the product and its intended use, which the manufacturer has submitted to the responsible Technical Assessment Body for the issuing of the European Technical Assessment.
10. Pursuant to Article 11(3) of Regulation (EU) N° 305/2011, manufacturers shall adequately take into account changes in the product-type and in the applicable harmonised technical specifications. Therefore, when the contents of the issued European Technical Assessment do not any longer correspond to the product-type, the manufacturer should refrain from using this European Technical Assessment as the basis for their declaration of performance.
11. All rights of exploitation in any form and by any means of this European Technical Assessment is reserved for UBAtc and the ETA-holder, subject to the provisions of the applicable UBAtc regulations.
12. Reproduction of this European Technical Assessment including transmission by electronic means shall be in full. However, partial reproduction can be made with the written consent of UBAtc. In this case partial reproduction has to be designated as such. Texts and drawings of advertising brochures shall not contradict or misuse the European Technical Assessment.
13. Subject to the application introduced, this European Technical Assessment is issued in English and may be issued by the UBAtc in its official languages. The translations correspond fully to the English reference version circulated in EOTA.
14. This European Technical Assessment, ETA 12/0551, was first issued on 12 June 2018 and replaces European Technical Approval, ETA 12/0551, issued on 27 June 2013. Compared with the European Technical Approval, an additional anodizing plant and stainless steel as an adhesion surface have been added.

¹ OJEU, L 88 of 2011/04/04

² OJEU, L 289 of 2013/10/31

Technical provisions

1 Technical description of the product

1.1 Definition of the product and intended use

1.1.1 Definition of product

The WICTEC 50SG kit is a structural sealant glazing kit (SSGS) in which the glazing infills are bonded along all four or along two opposite sides with a structural sealant to a metallic structural sealant support frame. This structural sealant glazing kit applies to infill elements for glass façades.

The WICLINE 90SG kit is a structural sealant glazing kit (SSGS) in which the glazing infills are bonded along the perimeter with a structural sealant to a metallic structural sealant support frame. This structural sealant glazing kit applies to opening parts for glass façades.

Both WICTEC 50SG and WICLINE 90SG share much of their detailing. They differ in that WICTEC 50SG offers an "all-glass" outer face (albeit with the possibility of visible transom or mullion cover caps) whereas WICLINE 90SG offers opening parts.

In the case of fixed fields and for those edges not retained by a transom or mullion cover cap, the support frame consists of U-shaped aluminium or stainless steel structural sealant retaining profiles, inserted between two glass panes of the insulating glazing unit.

Double glazing: The U-profile is affixed to the inner glass pane of the insulating glazing unit using an adhesive spacer; the outer glass pane is bonded to the inner glass pane and to the U-profile using a structural sealant.

Triple glazing variation 1: The U-profile is affixed to the outer face of the middle glass pane using an adhesive spacer. The outer glass pane is bonded to the middle glass pane and to the U-profile using a structural sealant as indicated in annex 5.1.

Triple glazing variation 2: The outer glass pane of a triple glazing is bonded to the middle glass using a structural sealant and the middle glass is bonded to the inner glass pane and to the U-profile using a structural sealant as indicated in annex 5.2.

Fixed field panels: In the case of fixed field panels, the single or double glass unit is bonded to a structural sealant support frame using a structural sealant.

Note: for those facades where WICTEC 50SG uses no transom or mullion cover caps, all four edges of the fixed infills are provided with these U-shaped aluminium structural sealant retaining profiles.

In all other cases the infill edges under the cover caps are regular structural sealant glazing. These edges are clamped onto the facade structure.

In the case of opening parts, the insulating glass unit is bonded to a structural sealant support frame using a structural sealant.

The WICTEC 50SG / WICLINE 90SG kit is of the type I or II as per ETAG 002 SSGS table 1

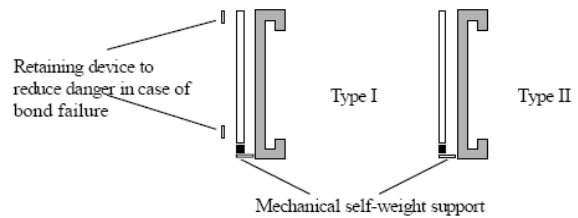

1.2 Components of the kit

1.2.1 Structural sealants

The following structural sealant types may be used:

- Silicone DOWSIL 993 or Sikasil SG-500 to seal the glazing on anodised aluminium or stainless steel structural sealant support frame
- Silicone DOWSIL 993, DOWSIL 3362, DOWSIL 3362 HD, DOWSIL 3363, Sikasil SG-500, IG-25 or IG-25 HM to seal the outer structural edge seal of the insulating glass unit

Identification and detailed mechanical characteristics are given in the respective ETA's:

Table 1 : applicable silicones

Silicone	ETA
Applicable silicones to seal the glazing on anodised aluminium or stainless steel structural sealant support frame	
DOWSIL 993	ETA 01/0005
SG-500	ETA 03/0038
Applicable silicones to seal the outer structural edge seal of the insulating glass unit	
DOWSIL 3362 or DOWSIL 3362 HD	ETA 03/0003
DOWSIL 3363	ETA 13/0359
IG-25	ETA 05/0068
IG-25 HM	ETA 05/0201

1.2.2 Structural sealant retaining profile and structural sealant support frame

As stated in the definition of the product, fixed parts contain a U-shaped aluminium or stainless steel structural sealant retaining profiles, inserted between two glass panes of the insulating glazing unit. Opening parts are affixed to a structural sealant support frame.

Note: not all four sides of a fixed part need to contain the aforementioned U-profile: see this ETA, chapter 1.1.

All profiles and frames for structural sealant application are made of an aluminium alloy as described in table 2 alternatively the U-shaped structural sealant retaining profile may be made from stainless steel as described below.

Table 2 : aluminium alloy – characteristics

Alloy Designation	Metallurgic state	Mechanical characteristics
EN 573-3	EN 515	
EN AW - 6060	T5/T66/T6	EN 755-2
EN AW - 6063	T6/T66	

Table 3 : anodising characteristics of the structural sealant adhesion surface

Characteristics	Method	EOTA Criteria	Nominal value
Thickness	ETAG, clause 5.2.2.2.1	Mean minimum thickness 15 µm	15 < th < 25
Sealing degree weight loss	ETAG, clause 5.2.2.2.2	EN ISO 3210: < 30 mg/dm³	< 30mg
Admittance at 1.000 Hz for a given thickness of 20µm	ETAG, clause 5.2.2.2.3	EN ISO 2931: < 20 µS	
Stain test	ETAG, clause 5.2.2.2.2	EN ISO 2143: < 2 on Qualanod scale	< 2

The anodising is performed by the companies listed in § 2.2.2.

- The anodized aluminium U-profile, which is to be inserted between the glass panes of the IGU is identified as profile 3030097.
- The stainless steel U-profile which is to be inserted between the glass panes of the IGU is identified as (material grade and finishing as per EN 10088-2):
 - Profile 4080051: stainless steel grade 1.4571, sandpapered with grain 180
 - Profile 4080052: stainless steel grade 1.4301, finishing 2B
 - Profile 4080053: stainless steel grade 1.4301, finishing 2R
- The profile for bonding a single glazing which is thus not a part of an insulating glass unit is identified as profile 3030114 or 3030122.
- The insert profile for bonding an insulating glass unit for the creation of opening parts is identified as profile 3091000.

Compatibility of the structural sealant and the materials which come in contact with it (VMQ silicone setting block part 4020566, HTV silicone rubber gasket 169-5, silicone joint profile 4010071, VMQ silicone adhesive spacer profile 190232, closed-pore polyethylene copolymer foam adhesive spacer tape 4090082, joint sealant) have been positively evaluated.

1.2.3 Suitable substrates for structural sealant bonding

The generic types of suitable substrates for adhesion to the structural sealant are:

- Float glass of soda lime silicate

The float glass shall conform to the following standard EN 572-1, -2, -4 and -5.

- Coated float glass

The suitable coated glass substrates are identified in the relevant ETA for structural glazing sealants; some other suitable coated glass products for the structural adhesion may be extrapolated following the rules mentioned in the ETAG 002, clause 5.2.3.3 (coated glass) without further testing for coatings classified as A, S and B according to EN 1096-1.

For other types of coated float glass the coating shall be totally removed from the structural adhesion surface.

- Laminated safety glass

Laminated safety glass shall conform to the following standard: EN ISO 12543-2

- Thermally treated glass

Thermally treated glass shall conform to the following standards: EN 1863 or EN 12150

For special applications, the heat strengthened shall in addition conform to EN 14179

Heat soaked thermally toughened safety glass shall be produced by using float glass according to above section on float glass with provisions of the member states being complied with.

1.2.4 Insulated glass unit

The kit of WICTEC 50SG/WICLINE 90SG is designed in such a way that the IGU outer edge seal is a structural edge seal.

The Insulated Glass Unit (IGU) is manufactured in accordance with EN 1279 series; insulated glass units made of two or three panes are covered in this ETA.

The structural outer edge seal is a silicone sealant conform to ETAG 002 identified in table 1

For each project the IGU's manufacturer shall deliver a technical dossier to his client as described in ETAG 002, clause 8.3.2.4.2 – VI (Checks on incoming material, insulating glass units).

Dimensional tolerances on the IGU: ± 2 mm on the glass pane.

1.2.5 Mechanical self-weight support

Mechanical self-weight supports shall be used, at a rate of two for every infill. They each support a setting block which supports all glass panes of the insulating glass units.

Examples of these self-weight supports are given in this ETA, annexes 8, 8.1, 13 and 13.1. The self-weight supports shall be 100 mm or 150 mm wide and of an aluminium alloy according to this ETA, table 2.

The mechanical self-weight supports are identified as parts

- For WICTEC 50SG: 4080251, 4080252, 4080253, 4080254, 4080255, 197265 (meter ware: 135147), 197266 (meter ware: 135148), 197279, 4080409, 4080410, 4080411, 4080412, 4080413, 4080414, 4080415, 4080416
- For WICLINE 90SG: 4080281, 4080282, 4080283, 4080284, 4080285, 4080286, 4080287, 4080288, 4080289, 4080389, 4080390, 4080391, 4080392

1.2.6 Retaining device

Retaining devices are means of retaining the glass to reduce danger in the event of structural sealant bond failure.

The necessity of these accessories is to be evaluated in function of the security specifications, of the situation of the building and of its working condition and also according to country demands.

Two types of retaining devices are used: circular retaining devices for fixed parts (part number 4080400, see this ETA, annex 7) and rectangular retaining devices for opening parts (part number 4080290, 4080291, 4080292, 4080293, 4080294, 4080295, 4080296, 4080297, 4080298, 4080299, 4080407, 4080408; see this ETA, annex 12). They shall be of an aluminium alloy according to this ETA, table 2.

1.2.7 Glass holders

The glass holder is a device used to fix the fixed infill assemblies onto the support structure, thus allowing the factory-assembled infill elements to be rapidly mounted on-site. In isometric drawing of the glass holder is depicted in this ETA, annexes 8 and 8.1.

The glass holder (part number 4080312 and 4080373) is composed of two parts: a metallic part made of ZnAl4Cu3 (ZL0430) according to EN 12844 and a bottom part of PA-66GF25. The metallic part is automatically turned into the aluminium U-profile 3030097 by an appropriate self-tapping countersunk screw according to EN ISO 7050.

1.2.8 Joint sealing

After assembly, the joints between infill elements are to be sealed with one of the sealants below:

- DOWSIL 791 (Dow)
- DOWSIL 797 (Dow)
- Sikasil WS-605 S (Sika AG)

1.2.9 Accessories

1.2.9.1 Aluminium profiles

- Fixed sash profile (profile 3030095)
- Opening sash profile for attachment of insert 3091000 (profile 3030096 and 3030123)

1.2.9.2 Aluminium crimping parts

- Sash corner connector (part 4050466, 4050469, 4050472, 4050474, 4050480, 4050481, 4050532)
- Mullion cap (profile 135071, 135072, 135073, 135074, 135191, 135226, 135268, 135296, 135318, 133222, 133333, 927604, 927614)
- Mullion cap baseplate (profile 135193, 135069)

1.2.9.3 Gaskets (fixed field)

- Sealant rank gasket (profile 190472)
- High thermal insulation sealant rank gasket (profile 4090083)
- Mullion gasket (profile 190280, 190281, 190282)
- High thermal insulation mullion gasket (profile 190283, 190284, 190285)
- Transom gaskets (profile 190286, 190287, 190288)
- High thermal insulation transom gaskets (profile 190289, 190290, 190291)
- Glazing gasket (profile 4010442)

1.2.9.4 Gaskets (opening part)

- Outer sash gasket (profile 4020563, 4020564, 4020565, meter ware 4010398 4010399, 4010400, 4010452, 4010453, 4010454)
- First centre sash gasket (profile 4020558, 4020559)
- Hi gasket (profile 4010455)
- Second centre sash gasket (profile 4020560, 4020561)
- Inner stop sash gasket (profile 4010045)
- Outer compensating gasket (profile 4010412, 4010413, 4010414, 4010415, 4010416, 4010417, 4010437)
- Inner compensating gasket (profile 4910026, 4910027, 4910028, 4910029, 4910030, 4010456)
- Sealant glazing gasket (profile 4010071, 4010459)

1.2.9.5 Thermal break profile

- Transom/mullion thermal break (profile 196059, 196060, 196061, 196062, 196063, 196064, 4030268, 4030267, 4030286)
- Compensation mullion/transom thermal break (profile 196065, 196066, 196067 196068, 196069)
- Gasket support profile (profile 4030213, 4030228, 4030276, 4030278, 4030279, 4030280)
- Profile for junction to structure (profile 4030247)

1.2.9.6 Mullion cavity drainage

- Drainage part (part 192225, 192241, 192242, 192243, 192244, 192245, 192268, 192269, 192270, 192271)

1.2.9.7 Adhesive spacer

When applying a structural sealant to a single glass pane which is thus not a part of an insulating glass unit, an adhesive spacer (silicone profile 190232) is used to prohibit the flux of sealant outside the foreseen structural adhesion surface.

1.2.9.8 Adhesive spacer tape

When affixing the U-profile to the insulating glass unit, a closed-pore polyethylene copolymer foam adhesive spacer tape (profile 4090082) is used to temporarily keep the profile in place when inserting the structural sealant silicone kit. This tape also prohibits direct contact between the aluminium and glass surfaces.

1.2.9.9 Iron work

Parallel outward opening sash:

- brand Securistyle, type Parallel Plus-PX

Top hung sash with friction stays:

- brand Securistyle, type SPT 10, type SPT 12, type SPT 16W, type SPT H16, type SPT 22, type SPT 22W, type SPT 26
- brand WICONA; type SK1-40, type SK2-50, type SK3-65, type SK3-100, type SK3-150, type SK4-100, type SK5-180

1.2.9.10 Setting blocks

The glazing dead load is transferred by setting blocks with suitable hardness and compatible with the sealants in this ETA, table 1.

The setting blocks are identified as parts 4020566, 4020567, 4020594 and 4020595.

1.2.9.11 Cleaning products for the adhesive surface

The cleaning products used for cleaning of the adhesive surface, should be those recommended by the sealant suppliers. The processing instructions of the adhesive suppliers shall also be respected. This information may be found in the applicable ETA enumerated in this ETA, Table 1.

2 Specification of the intended use(s) in accordance with the applicable EAD

2.1 General

Structural sealant glazing kit (SSGS) for use as infill for curtain walling ranging from a vertical position to 80° from the vertical ($0^\circ \leq \theta < 80^\circ$), onto the building facade. An inclination is only allowed towards the inside of the building, as tensile stress of the structural sealant resulting of the self-weight is not allowed.

The infill elements may only be used for installation heights that are admissible by regulations of the respective member states. The infill may also be used in overhead area. The inner pane of the insulating glass unit placed overhead shall be laminated safety glass as described in this ETA, clause 1.2.2. The façade structure is not part of the present ETA. The infill elements shall not be used for the stiffening of other components.

The restrictive provisions of the various member states with regard to the application shall be taken into consideration. Due to national requirements in some countries, retaining devices may need to be used.

The system is intended to be used in curtain walling for which requirements ER2 safety in case of fire, ER3 Hygiene, Health and Environment, ER4 Safety in use, ER5 Protection against noise and ER6 Energy economy and heat retention shall be fulfilled. The failure of the structural bond would cause risk to human life and/or considerable economic consequences.

The provisions made in this European Technical Assessment are based on the assumed working life of the SSGS of 25 years. The assumed working life of a system cannot be taken as a guarantee given by the producer, but are to be used as a means for selecting the appropriate product in relation to the expected economically reasonable working life of the works.

2.2 Provisions related to manufacturing, packaging and storage

2.2.1 Manufacturing

This European Technical Assessment is issued for the kit on the basis of agreed data / information deposited with the UBAtc, which identifies the product that has been assessed and judged. Changes to the product or production process, which could result in this deposited data / information being incorrect should be notified to the UBAtc before the changes are introduced. UBAtc decides whether such changes do or do not affect the ETA.

The infill elements may only be manufactured and sealed in plants that are authorised by Hydro Building Systems for producing such infill units. The personnel performing these duties shall be adequately trained by the adhesive manufacturers.

The surfaces to be sealed may only be prepared in conformity with the manufacturing directives (see this ETA, clause 1.2.9.11, Cleaning products for the adhesive surface).

2.2.2 Bonding the glazing

The use of primer is assessed per batch of adaptor by adhesion test with the project structural sealant(s). The anodising of the structural adhesion surface profiles (3030097, 3030114, 3030122 and 3091000) is performed by the following companies:

- BWG Altenheim AG, CH-9423 Altenheim
- Piesslinger, im Gstadt 1, A-4591 Molln
- Eloxal Gerhard Gotta, Max-Planck-Str.12, D-63322 Rödermark
- HD Wahl GmbH, Dieselstrasse 6-8, D-89343 Jettingen Scheppach, Germany

The anodised aluminium profiles have been assessed as suitable adhesion substrates for the bonding. The following combinations of anodizing/sealant have been assessed fit for use:

Anodizing	Sealant	Cleaner	Primer
Eloxal Gerhard Gotta			Not necessary
BWG Altenrhein AG	DOWSIL 993	Cleaner R40	Primer DOWSIL 1200
Piesslinger GmbH			Not necessary
HD Wahl GmbH			Primer DOWSIL 1200
Eloxal Gerhard Gotta			Not necessary
BWG Altenrhein AG	SG-500	Cleaner G & M	Not necessary
Piesslinger GmbH			Not necessary
HD Wahl GmbH		Cleaner P, or Cleaner G & M	Not necessary

The stainless steel profiles have been assessed as suitable adhesion substrates for the bonding. The following combinations of stainless steel grade/finishing/sealant have been assessed fit for use:

Sealant	Cleaner	Activator	Primer
Profile 4080053: Stainless steel grade 1.4301, finishing 2R			
DOWSIL 993	Cleaner R40		Primer DOWSIL 1200-OS
SG-500	Cleaner P, or Cleaner G & M	Activator 205 or Activator	Primer 790 or Primer 210
Profile 4080051: Stainless steel grade 1.4571, sandpapered with grain 180			
SG-500	Cleaner P, or Cleaner G & M	Activator 205 or Activator	Primer 790 or Primer 210
Profile 4080052: Stainless steel grade 1.4301, finishing 2B			
SG-500	Cleaner P, or Cleaner G & M	Activator 205 or Activator	Primer 790 or Primer 210

After adhesion tests by the sealant supplier, the sealant suppliers can always demand the use of primers. In such cases primers shall be used even if no primers are indicated in the tables above.

The structural bond in the space between the glass and the aluminium u-profile shall be completely filled all around. Bubbles, voids or inclusions in the structural sealant are not permissible.

2.3 Provisions related to the design and use of the product

2.3.1 Design rules

2.3.1.1 Structural seals design

The structural sealant shall be calculated in accordance with ETAG 002, annex 2 and according to national design rules with the design values given in this ETA, clause 2.1.8, respecting the following conditions: Minimum dimensions of structural seal are $e \geq 6 \text{ mm}$, $h_c \geq 6 \text{ mm}$, $r \geq 6 \text{ mm}$ (ETAG 002, amended 2001, annex 2, figure A2); however, these values have to be determined by calculation case-by-case.

2.3.1.2 Design rules for the frames

The frames are designed following the specifications of EN 13830 and national provisions, the windows according to EN 14351-1 and national provisions.

2.3.1.3 Maximum dimensions

The infill elements shall not exceed (width x height): 2,00 m x 4,00 m or 4,00 m x 2,00 m. The opening parts shall not exceed (width x height):

- for top hung sashes with friction stays: 1,50 m x 2,50 m or 2,00 m x 1,70 m
- for parallel outward opening sash: 1,50 m x 3,00 m or 2,00 m x 1,50 m

2.3.1.4 Transfer of the dead load of the infill panel to façade structure (for fixed part and opening light)

The mechanical self-weight support devices are given in this ETA, clause 1.2.5. The load bearing capacity of the following parts has been verified:

- 4080252 (longest non-reinforced mechanical self-weight support for fixed parts): 2851 N (with a safety factor of 1,25)
- 4080255 (longest reinforced mechanical self-weight support for fixed parts): 1957 N (with a safety factor of 1,25)
- 4080284 (longest non-reinforced mechanical self-weight support for sashes): 989 N (with a safety factor of 1,25)
- 4080289 (longest reinforced mechanical self-weight support for sashes): 919 N (with a safety factor of 1,25)
- 4080409 (longest reinforced mechanical self-weight support for fixed parts): 2700 N (with a safety factor of 1,25)
- 4080411 (longest reinforced mechanical self-weight support for fixed parts): 1700 N (with a safety factor of 1,25)
- 4080413 (longest reinforced mechanical self-weight support for fixed parts): 1250 N (with a safety factor of 1,25)
- 4080414 (longest reinforced mechanical self-weight support for fixed parts): 7100 N (with a safety factor of 1,25)
- 4080416 (longest reinforced mechanical self-weight support for fixed parts): 3200 N (with a safety factor of 1,25)
- 4080390 (longest reinforced mechanical self-weight support for sashes): 840 N (with a safety factor of 1,25)
- 4080392 (longest reinforced mechanical self-weight support for sashes): 510 N (with a safety factor of 1,25)

2.3.1.5 Retaining devices and glass holders

The retaining devices are given in this ETA, clause 1.2.6. The load bearing capacity of the following parts has been verified:

- 4080316 (infill retainer for opening elements): 1673 N (with a safety factor of 2,21)
- 4080400 (infill retainer for fixed elements): 2000 N (with a safety factor of 2,21)
- 4080293 (infill retainer for opening elements): 1758 N (with a safety factor of 2,08)
- 4080407 (infill retainer for opening elements): 2350 N (with a safety factor of 2,08)
- 4080408 (infill retainer for opening elements): 2000 N (with a safety factor of 2,08)

The glass holders are given in this ETA, clause 1.2.7

The load bearing capacity of the following parts has been verified:

- 4080312 (glass holder): 1900 N (with a safety factor greater than 2)
- 4080373 (glass holder): 2086 N (with a safety factor greater than 2).

2.3.1.6 Iron work

Parallel outward opening sash: up to 2 locking points on the top, up to 5 on the side, up to 1 on the bottom; up to 1 hinge on the top, up to 2 hinges on the sides, up to 1 hinge on the bottom.

- brand Securistyle: type Parallel Plus-PX, maximum vent weight 55 kg per hinge cross (vertical mounted)

Top hung sash with friction stays: up to 3 locking points on the top, up to 4 on the side, up to 3 on the bottom; two friction stays on the sides.

- brand Securistyle:
 - type SPT 10, maximum vent weight 40 kg
 - type SPT 12, maximum vent weight 50 kg
 - type SPT 16W, maximum vent weight 65 kg
 - type SPT H16, maximum vent weight 100 kg
 - type SPT 22, maximum vent weight 100 kg
 - type SPT 22W, maximum vent weight 100 kg
 - type SPT 26, maximum vent weight 180 kg
- brand WICONA:
 - type SK1-40, maximum vent weight 40 kg
 - type SK2-50, maximum vent weight 50 kg
 - type SK3-65, maximum vent weight 65 kg
 - type SK3-100, maximum vent weight 100 kg
 - type SK3-150, maximum vent weight 150 kg
 - type SK4-100, maximum vent weight 100 kg
 - type SK5-180, maximum vent weight 180 kg

2.3.2 Installation – Specification on the façade structure

The elements shall be bonded with respect to the provisions in the workshop manual of the company Sapa-Building-Systems GmbH, in a way that no restraints in the elements may occur. The installation shall be performed by trained personnel only, who have been trained for these works by the company Sapa-Building-Systems GmbH.

2.3.3 Maintenance and repair

2.3.3.1 Repair

All damages noticed on the structural sealant system shall be repaired as follows:

- Dismantling of the structural sealant unit
- Replacement by a new unit or
- Repair of the damaged unit in the workshop

2.3.3.2 Maintenance

The cleaning of the façade shall be carried out only with water adding a maximum of 1% of surfactants without other chemical additions or other cleaning methods (e.g. steam pressure rays).

Other products may be used provided they are assessed for conformity to ETAG § 5.1.4.2.4 (façade cleaning products)

3 Performance of the product and references to the methods used for its assessment

3.1 General

The assessment of the structural sealant for the intended use in relation to the requirement for safety in case of fire, hygiene, health and environmental safety in use, protection against noise, energy economy and heat retention, in the sense of Essential Requirements 2 to 6 has been made in accordance with ETAG 002.

Except the characteristics of the bonding itself, most of the performances cannot be assessed as they are applicable not only to the glazing frame alone. However, the performances of the assembled façade shall be assessed according to EN 13830.

3.2 Safety in case of fire (ER2)

Reaction to fire: No performance assessed (no tests performed)

Resistance to fire: No performance assessed claimed

3.3 Hygiene, Health and the environment (ER3)

3.3.1 Air permeability

Class AE according to EN 12152

3.3.2 Water tightness

Class RE 750 according to EN 12154

No dampness due to water penetration or due to condensation appears at any position not designed to be subjected to the prolonged effects of liquid water.

3.3.3 Dangerous substances

Relating to the "Dangerous substances" the manufacturer of the elements has made a declaration of compliance with Council Directive 76/769/EC of July 1976.

In addition to the specific clauses relating to dangerous substances contained in this European Technical Assessment, there may be other requirements applicable to the products falling within its scope (e.g. transposed European legislation and national laws, regulations and administrative provisions). In order to meet the provisions of the EU Construction Products Regulation, these requirements need also to be complied with, when and where they apply.

3.4 Safety in use (ER4)

3.4.1 General

Stability of the elements and their anchorage on the structure is demonstrated. The following aspects have been particularly considered:

- Self-weight
- Wind
- Temperature
- Climatic conditions.

3.4.2 Verification of structural bond

It shall be verified that the structural bond under the actions given in this ETA, clause 3.4.1, is not exposed to any stresses exceeding $0,14 \text{ N/mm}^2$ perpendicular to the adhesion surface. Compared to a continuous load, the internal forces and moments in the structural bond are to be multiplied by a factor $\gamma_{\text{sys}} = 3.0$. The shear deformation of the seam due to temperature differences of $\Delta T = 35 \text{ K}$ shall be smaller than 23.4 %.

Design of the structural bond shall be carried out in accordance with the regulations of the Member States, in which the infill will be used. The Member State may thereby refer to the design recommendations in ETAG 002.

3.4.3 Verification of the insulating glass

The verification of the stability of the panels shall be made under the actions mentioned in this ETA, clause 3.4.1, according to the rules of the responsible member state.

3.4.4 Verification of support

The support 4080252 according to this ETA, Annex 8 is designed to bear the self-weight of the fixed field infill elements and has a permissible load of up to 2851 N (per support) with a safety factor of 1,25 or greater.

The support 4080416 according to this ETA, Annexes 8.1 and 8.2, is designed to bear the self-weight of the fixed field infill elements and has a permissible load of up to 1680 N (per support) with a safety factor of 1,25 or greater.

The support 4080289 according to this ETA, Annex 13, is designed to bear the self-weight of the sash infill elements and has a permissible load of up to 919 N (per support) with a safety factor of 1,25 or greater.

The support 4080293 according to this ETA, Annex 13.1, is designed to bear the self-weight of the sash infill elements and has a permissible load of up to 510 N (per support) with a safety factor of 1,25 or greater.

3.4.5 Deflection of the frames

The deflection of the framing profiles supporting the glass pane shall not exceed – in the area of the pane edge – $1/300$ of the concerned edge length, additionally for insulating glass unit glass pane edges the deflection shall not exceed 12 mm. The deflection of the glass panel in the centre of the pane in case of service load shall not exceed $1/100$ of the smallest support edge of the glass pane.

3.4.6 Verification of retaining device (fixing)

The retaining device shall be locked into the infill elements retaining profile at a distance from the infill corner of not more than 225 mm and with a distance between retaining devices of not more than 500 mm.

The admissible load bearing capacity of a retaining device with anchoring bolt according to (see this ETA, annexes 8 and 8.1) is assessed and equals 1900 N with a safety factor greater than 2.

3.4.7 Sill heights

Sill heights may be adapted to any required height.

The regulations in the Member States, in which the structural sealant glazing kit is used, shall be observed.

3.4.8 Impact resistance

In the context of issuing this ETA, the verification of impact of the structure was performed and classified to I5/E5 according to EN 14019.

The regulations concerning barrier against falling through in the Member States, in which the structural sealant glazing kit is used, shall be observed.

3.4.9 Wind resistance

The design load (Service Limit State characteristic wind load for serviceability, EN 13116) is 2000 N/m² (positive and negative loads) for the facade construction. The wind load safety (Ultimate Limit State, EN 13116) is 3000 N/m² (positive and negative loads) for the facade construction.

Opening parts are classified as C4 according to EN 12210.

The regulations in the Member States, in which the structural sealant glazing kit is used, shall be observed.

3.4.10 Behaviour in fire

No performance assessed. The regulations in the Member States, in which the structural sealant glazing kit is used, shall be observed.

3.4.11 Flexural tensile strength

No characteristic value of the flexural tensile strength of the multi-pane insulating glass has been assessed. The regulations in the Member States, in which the structural sealant glazing kit is used, shall be observed.

3.5 Protection against noise (ER5)

In the context of issuing this ETA, the verification of performance capacities of the protection against noise has not been assessed. For the structure verification regarding the protection against noise, the regulations of the Member States apply.

3.6 Energy economy and heat retention (ER6)

The U_f values are calculated according to EN ISO 10077-2.

Table 4 : U_f values of typical sections

	U _f W/(m ² × K)
fixed element (135002) + standard sealing joint backer (190472)	2,3
fixed element (135002) + high insulation sealing joint backer (4090083)	1,2
fixed element (135002) + opening part (3030096) + standard sealing joint backer (190472)	2,0
fixed element (135002) + opening part (3030123) + high insulation sealing joint backer (4090083)	1,1

For the structure verification regarding energy economy and heat retention, the regulations of the Members States apply.

4 Assessment and verification of constancy of performance (AVCP) system applied, with reference to its legal base

In accordance with Regulation (EU) N° 305/2011, Article 65, Directive 89/106/EEC is repealed, but references to the repealed Directive shall be construed as references to the Regulation.

The systems of assessment and verification of constancy of performance specified by the European Commission detailed in EC Decision 96/582/EC³ are as follows:

- System 1 (without audit testing of samples) for SSG kits Type II and IV;
- System 2+ (first possibility, including certification of the factory production control (FPC) by a notified body on the basis of its continuous surveillance, assessment and assessment) for SSG kits Type I and III

The system(s) of assessment and verification of constancy of performance are shown in the following Table.

Table 1 – System(s) of assessment and verification of constancy of performance

Product(s)	Intended use(s)	Level(s) or class(es)	Assessment and verification of constancy of performance system(s)*
Structural sealant glazing kits type II and IV	External walls and roofs	none	1
Structural sealant glazing kits type I and III		none	2+

* See Annex V to Regulation (EU) N° 305/2011

In practice, the operation of systems 1 and 2+ will be very similar for SSG kits, for the following reasons:

- the results of assessment testing shall be used by notified bodies (cf. Regulation (EU), Annex V, clause 1.6)
- the nature of the product is such that testing of samples at the factory by the manufacturer will be required under the FPC arrangements.

³ Commission decision of 24/06/96, published in the EC Official Journal L254 of 08/10/96

5 Technical details necessary for the implementation of the AVCP system

5.1 Tasks for the ETA-holder

5.1.1 Factory production control (FPC)

5.1.1.1 General

The manufacturer shall establish, document and maintain a FPC system to ensure that the products placed on the market conform to the assessed performance characteristics. The FPC system shall consist of procedures, regular inspections and tests and/or assessments and the use of the results to control raw and other incoming materials or components, equipment, the production process and the product.

A FPC system conforming with the requirements of EN ISO 9001, and made specific to the requirements of this ETA, is considered to satisfy the above requirements.

The results of inspections, tests or assessments requiring action shall be recorded, as shall any action taken. The action to be taken when control values or criteria are not met shall be recorded.

The ETA holder of the kit is responsible for setting up appropriate rules and instructions for façadiers and the bonding workshops (quality manual for kit assembling and bonding). The different actors are bound via contractual links with the ETA holder to respect the kit holder's rules and instructions, which are an integral part of the FPC system

The contractual links and their contents are described in the document GNB-CPD SG05 "Route to CE-marking", August 2003. However, in the case of a façade maker type C, an alternative appointment of responsibilities is provided.

In the framework of this ETA for the Structural Sealant Glazing frame, the façade makers are identified as being façade makers type B or type C (see below). Two or three manufacturing actors are involved:

- **The kit designer** is responsible for the design of the kit and its components. He is the ETA-holder.
- **Façade makers:** Several manufacturers who are responsible for assembling the kit components produced by one or more suppliers (generally the kit designer, but possibly others (glass, sealant, etc.)) in accordance with the specifications of the kit designer. The façade makers produce the metal frames, using the profiles supplied by the kit designer.
 - The **façade makers type B** have bonding equipment to perform the bonding work between the glazing product and the structural sealant support frame. The façade makers type B put products on the market and have to obtain a European Commission (EC) certificate of conformity.
 - The **façade maker type C** has no bonding facilities. A third actor involved in the manufacturing process: the bonding workshop. The façade makers type C put products as a complete system on the market but have the bonding workshop, with whom they have a legal link, to obtain a European Commission (EC) certificate of conformity.
- The **bonding workshops** (structural sealant applicators) are subcontractors of the façade makers type C. The bonding workshops perform the bonding works and are also the EC Certificate holder. The bonding workshop, prior to proceeding with bonding activities in the framework of CE-marking the kit, shall fulfil the requirements of the NB-CPD/SG05/03/007 position paper.

Bonding workshops are permitted to proceed with bonding activities in the framework of CE-marking the kit if they meet the requirements set out in NB-CPD/SG05/03/007 (§ 3.2 in particular), as documented in an assessment report, issued by an Assessment body or a notified body.

5.1.1.2 Equipment

All weighing, measuring and testing equipment shall be calibrated and regularly inspected according to documented procedures, frequencies and criteria.

5.1.1.3 Raw materials and components

The specifications of all incoming raw materials and components shall be documented, as shall the inspection scheme for ensuring their conformity.

5.1.1.4 Non-conforming products

In the event of any non-conformity of any product, that product shall be placed into quarantine and action taken to rectify the cause of the non-conformity. Products may not subsequently be dispatched until the problem has been resolved.

5.1.1.5 Tests and frequencies

All the elements, requirements and provisions adopted by the manufacturer are documented in a systematic manner in the form of written policies and procedures. This production control system ensures that the product is in conformity with the European Technical Assessment (ETA).

This relates only to taking samples representative of the final product. In the context of SSGS the testing of "H" pieces, peel tests as part of FPC provides the necessary evidence.

5.2 Tasks for the Technical Assessment Body

5.2.1 Initial Type Testing

Assessment tests on the sealant have been conducted under the responsibility by the assessment body (UBAtc) in accordance with Chapter 5 of the ETAG 002. The assessment body (UBAtc) has assessed the results of these tests in accordance with Chapter 6 of this ETAG, as part of the ETA issuing procedure. The results of assessment testing shall be used by notified bodies (cf. Regulation (EU), Annex V, clause 1.6).

5.2.2 Assessment of the factory production control - Initial inspection and continuous surveillance

Assessment of the FPC is the responsibility of a notified body.

An assessment shall be carried out on the required manufacturing steps of each manufacturing plant to demonstrate that the factory production control is in conformity with the ETA and any subsidiary information. This assessment is based on an initial inspection of the different manufacturing actors' plants. (Kit designer; façadier(-s) and bonding workshops)

Subsequently continuous surveillance of factory production control is necessary to ensure continuing conformity with the ETA. This continuous surveillance shall be in conformity with to ETAG 002 SSGS, chapter 8.3 at each identified manufacturing plant.

It is recommended that surveillance inspections should be conducted at least twice a year at each identified manufacturing plant.

6 Bibliography

ETAG 002 Structural sealant glazing kits Edition November 1999, 1st amendment: October 2001, 2nd Amendment: November 2005, 3rd amendment: May 2012.

EN 515 Aluminium and aluminium alloys. Wrought products. Temper designations

EN 572-1, -2, -3, -4 and -5 Glass in building - Basic soda lime silicate glass products

EN 573-3 Aluminium and aluminium alloys - Chemical composition and form of wrought products - Part 3: Chemical composition and form of products

EN 755-2 Aluminium and aluminium alloys - Extruded rod/bar, tube and profiles - Part 2: Mechanical properties

EN 1096-1 Glass in building - Coated glass - Part 1: Definitions and classification

EN 1279-1, -2, -3, -4, -5 and -6 Glass in building - Insulating glass units

EN 1863-1 and -2 Glass in building - Heat strengthened soda lime silicate glass

EN 12150-1 Glass in building - Thermally toughened soda lime silicate safety glass - Definition and description

EN 12150-2 Glass in building - Thermally toughened soda lime silicate safety glass - Evaluation of conformity/Product standard

EN 12152 Curtain walling - Air permeability - Performance requirements and classification

EN 12154 Curtain walling - Watertightness - Performance requirements and classification

EN 12210 Windows and doors - Resistance to wind load - Classification

EN 12844 Zinc and zinc alloys - Castings - Specifications

EN 13116 Curtain walling - Resistance to wind load - Performance requirements

EN 13830 Curtain walling - Product standard

EN 14019 Curtain Walling - Impact resistance - Performance requirements

EN 14179-1 and -2 Glass in building - Heat soaked thermally toughened soda lime silicate safety glass

EN 14351-1 Windows and doors - Product standard, performance characteristics - Part 1: Windows and external pedestrian doorsets without resistance to fire and/or smoke leakage characteristics

EN ISO 2143 Anodizing of aluminium and its alloys - Estimation of loss of absorptive power of anodic oxidation coatings after sealing - Dye-spot test with prior acid treatment

EN ISO 2931 Anodizing of aluminium and its alloys - Assessment of quality of sealed anodic oxidation coatings by measurement of admittance (ISO 2931:2010)

EN ISO 3210 Anodizing of aluminium and its alloys - Assessment of quality of sealed anodic oxidation coatings by measurement of the loss of mass after immersion in phosphoric acid/chromic acid solution

EN ISO 7050 Cross-recessed countersunk (flat) head tapping screws

EN ISO 9001 Quality management systems - Requirements

EN ISO 10077-2 Thermal performance of windows, doors and shutters - Calculation of thermal transmittance - Numerical method for frames

EN ISO 12543-2 Glass in building - Laminated glass and laminated safety glass - Part 2: Laminated safety glass

UBATc asbl is a non-profit organization according to Belgian law. It is a Technical Assessment Body notified by the Belgian notifying authority, the Federal Public Services Economy, SMEs, Self-Employed and Energy, on 17 July 2013 in the framework of Regulation (EU) No 305/2011 of the European Parliament and of the Council of 9 March 2011 laying down harmonised conditions for the marketing of construction products and repealing Council Directive 89/106/EEC and is member of the European Organisation for Technical Assessment, EOTA (www.eota.eu).

This European Technical Assessment has been issued by UBATc asbl, in Sint-Stevens-Woluwe, on the basis of the technical work carried out by the Assessment Operator, BCCA.

On behalf of UBATc asbl,

On behalf of the Assessment Operator, BCCA, responsible for the technical content of the ETA,

Peter Wouters,
Director



Benny De Blaere,
Director general

The most recent version of this European Technical Assessment may be consulted on the UBATc website (www.ubatc.be).

Annexes

Festverglasung
Fixed glazing

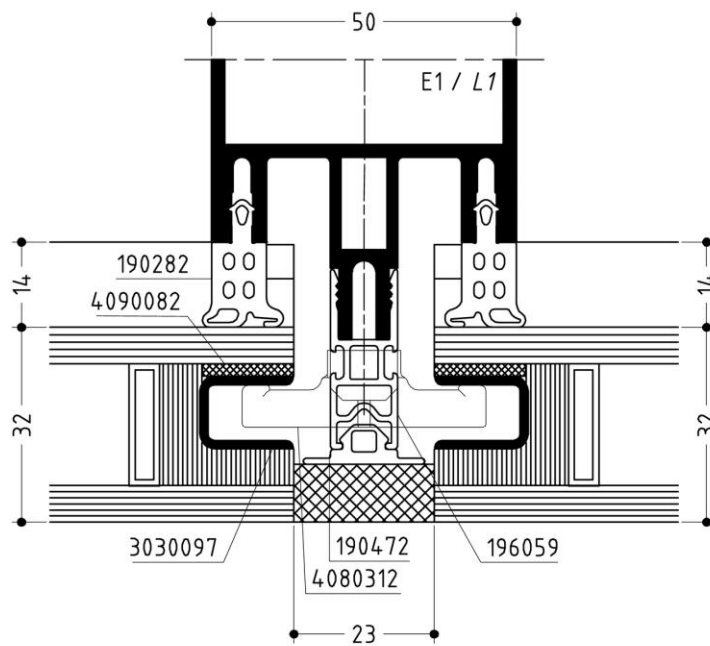
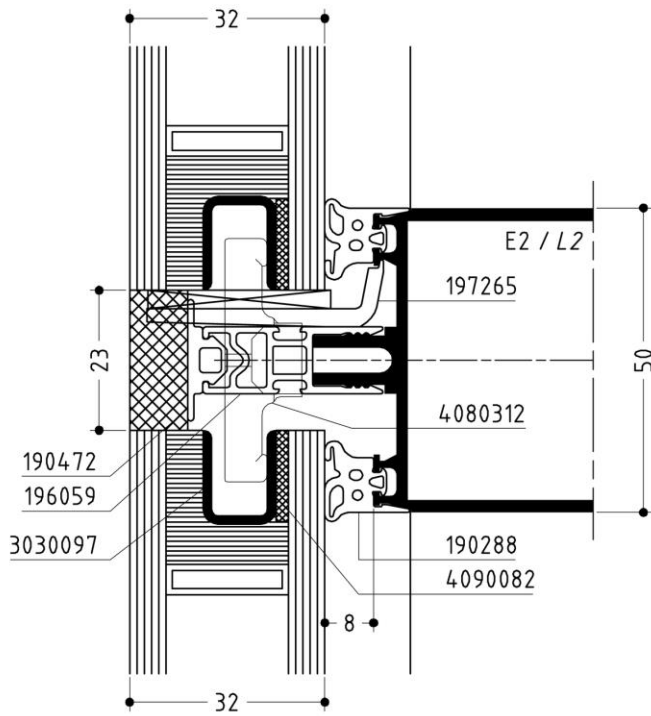
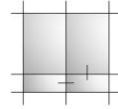
Construction section



WICONA® SEC-000038762 REV. B 25.07.2012
DOC-0000704645

Annex 1

Dreifach Verglasung, Festfeld
Triple glazing, fixed field

Construction section

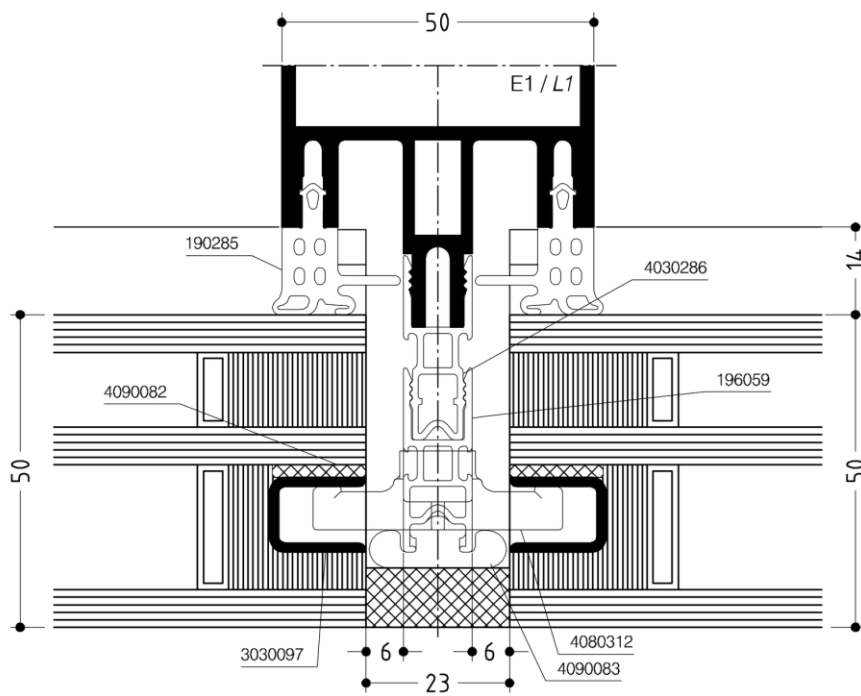
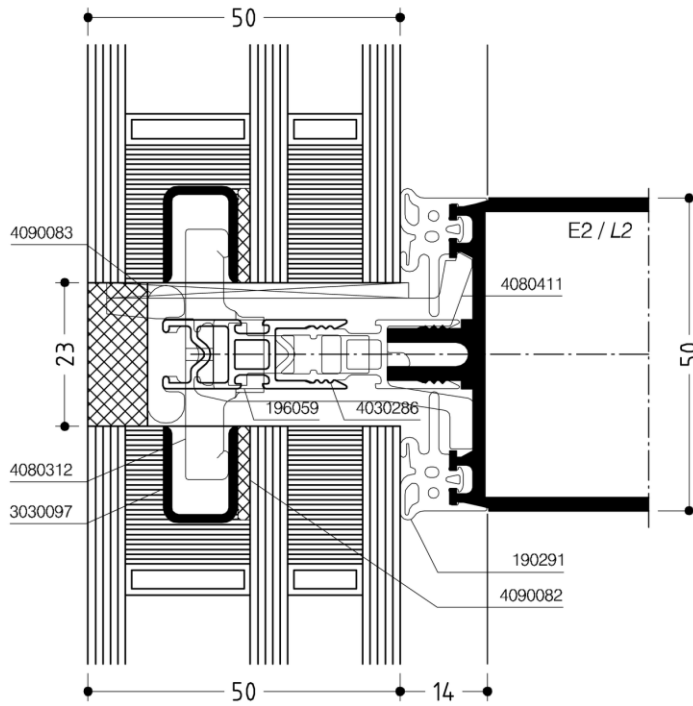
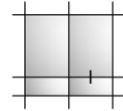

WICONA® DOC-0000824774 REV. A 25.07.2012

Annex 1.1

Dachschräge
Roof pitch

Construction section

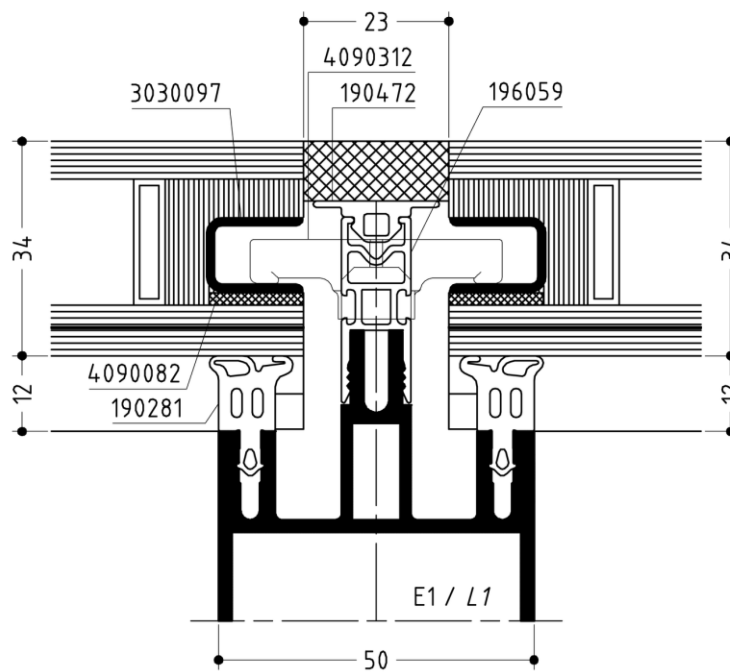
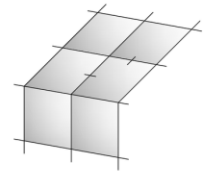
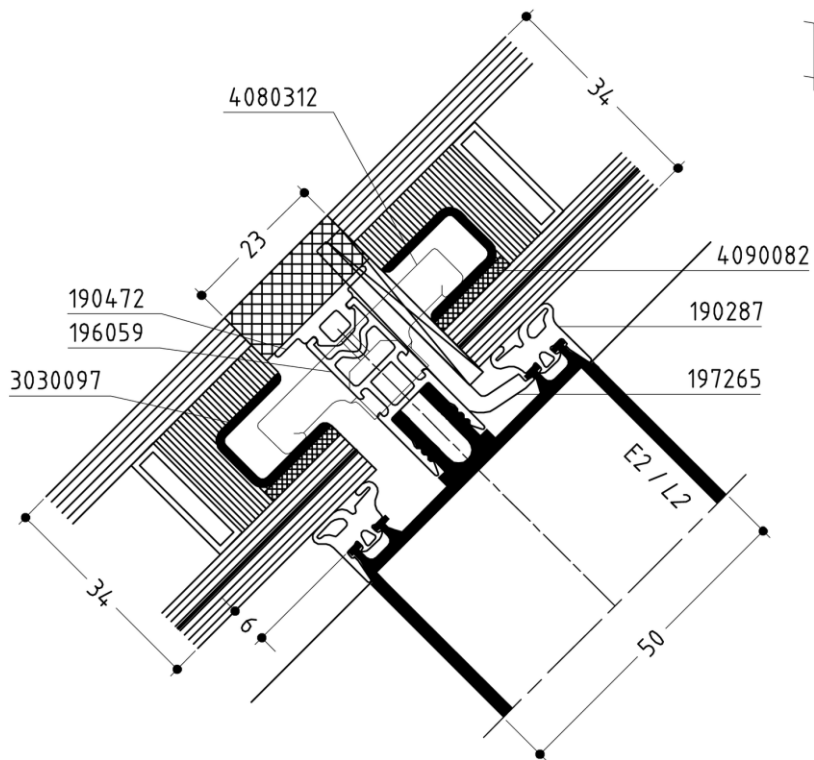

WICONA® SEC-000038761 REV. B 25.07.2012
DOC-0000704642

Annex 2

Glaspaneel
Glass panel

Construction section

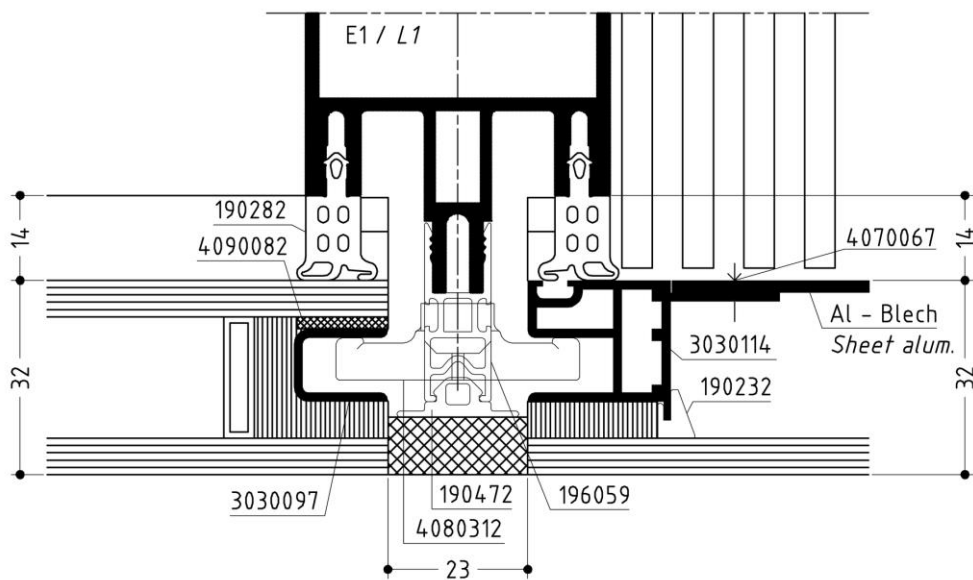
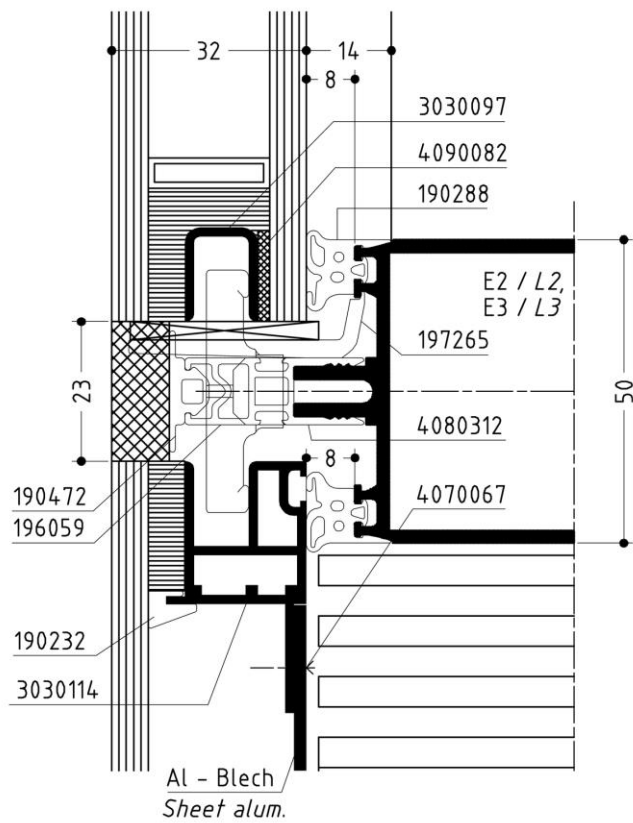
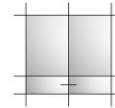

WICONA® SEC-000038764 REV. B 25.07.2012
DOC-0000704655

Annex 3

Semi - Fassade
Semi-façade

Construction section

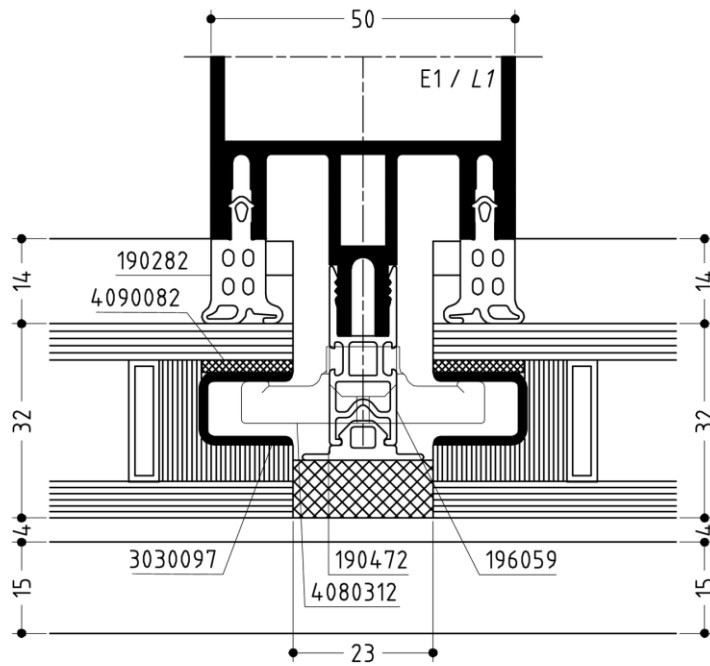
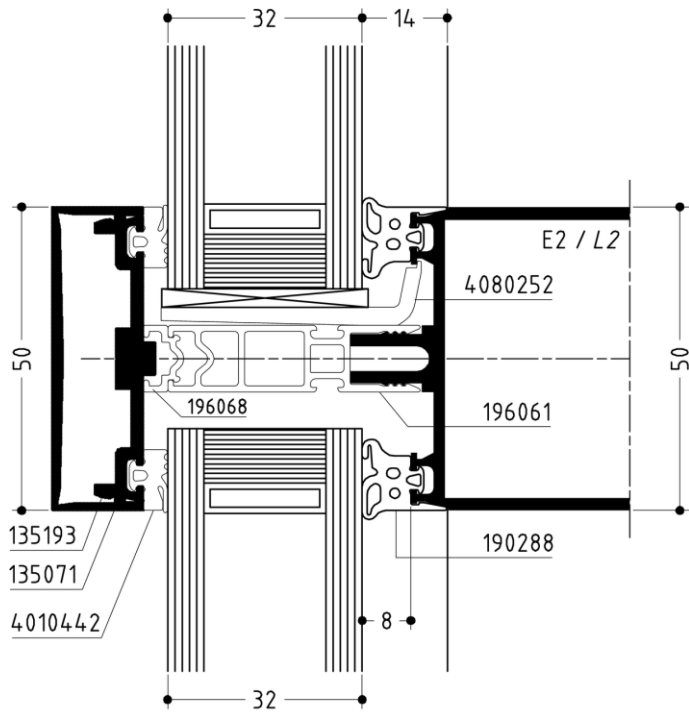
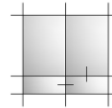

WICONA® SEC-000038759 REV. B 25.07.2012
DOC-0000704633

Annex 4

WICTEC 50SG

Verklebung
Gluing

Glaselement
Glass unit

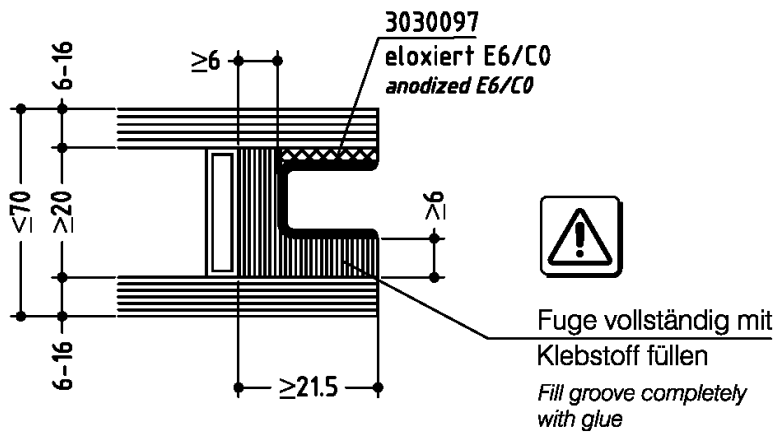
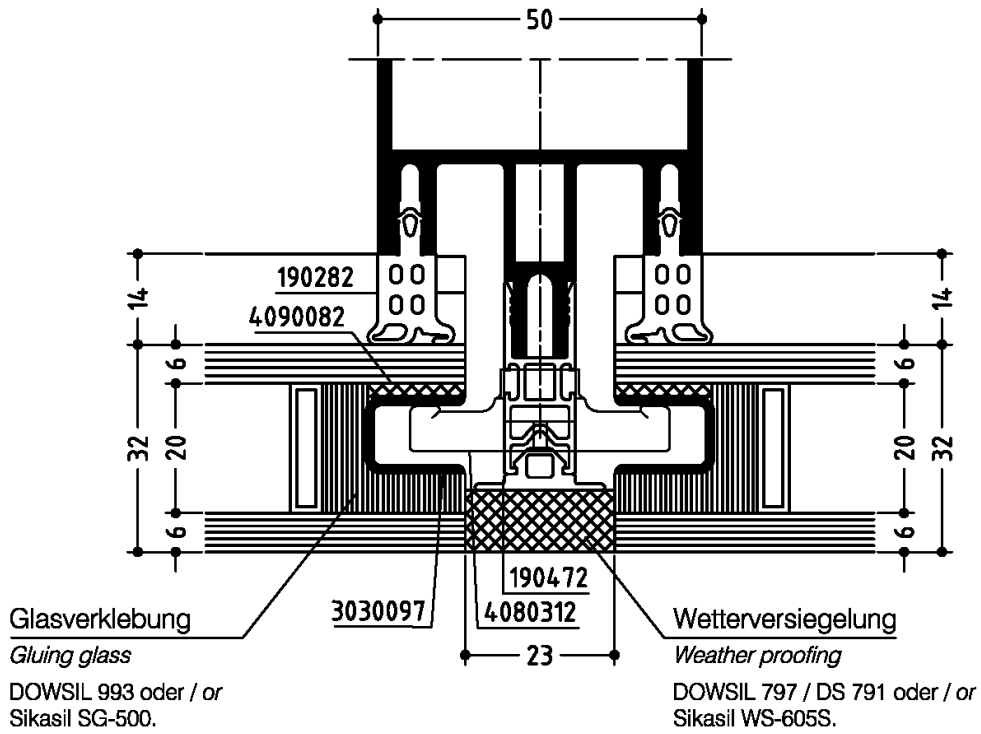

WICTEC 50SG

Verklebung 3 fach-Verglasung
Gluing triple-glazing

Technische Information
Technical Information

Variante 1
Version 1

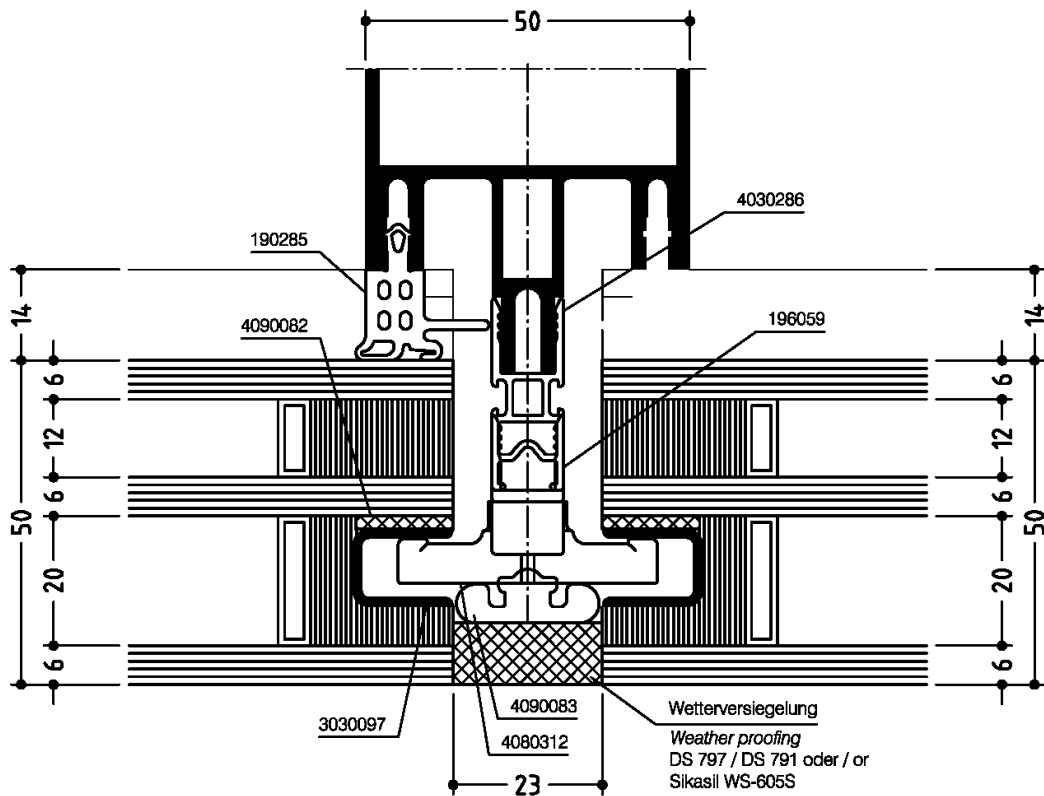

DS 3362 HD / DS 3362 / DS 3363 / DS 993
IG 25 / IG 25 HM / SG 500

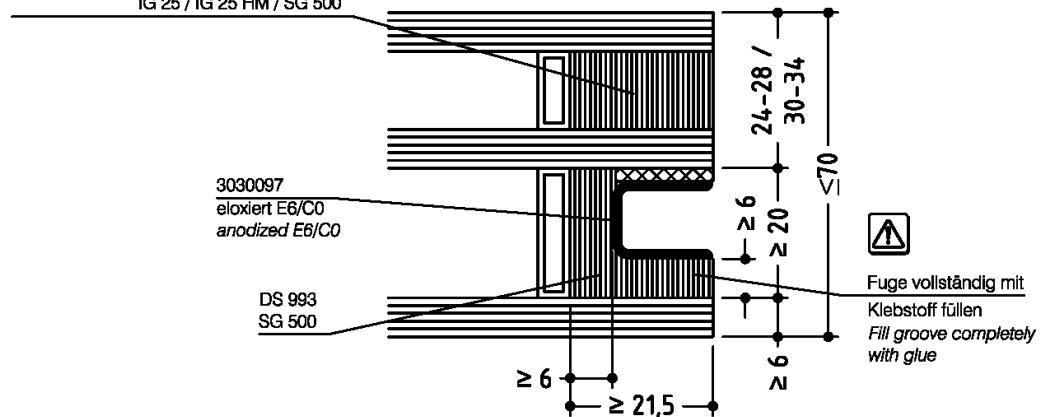

WICONA® DOC-0000824793 REV. C 17.04.2018

Annex 5.1

WICTEC 50SG

Verklebung 3 fach-Verglasung
Gluing triple-glazing

Technische Information
Technical Information

Variante 2
Version 2

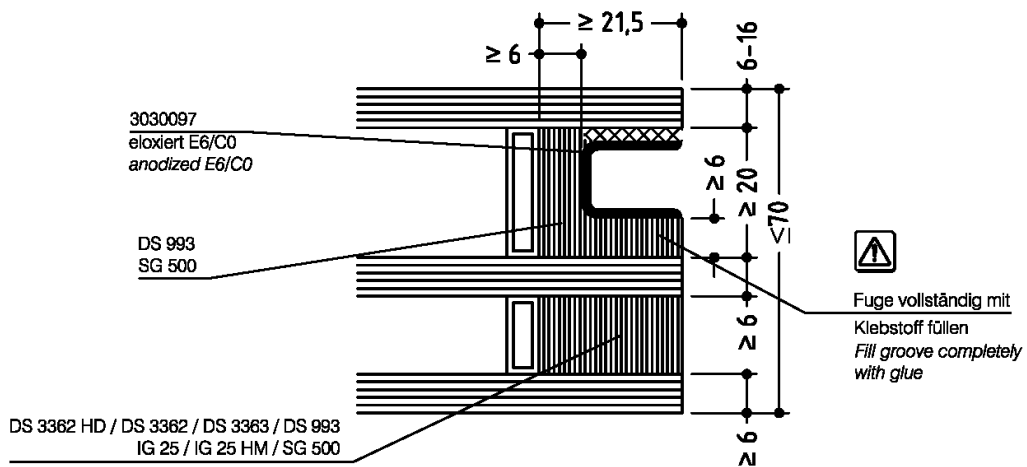
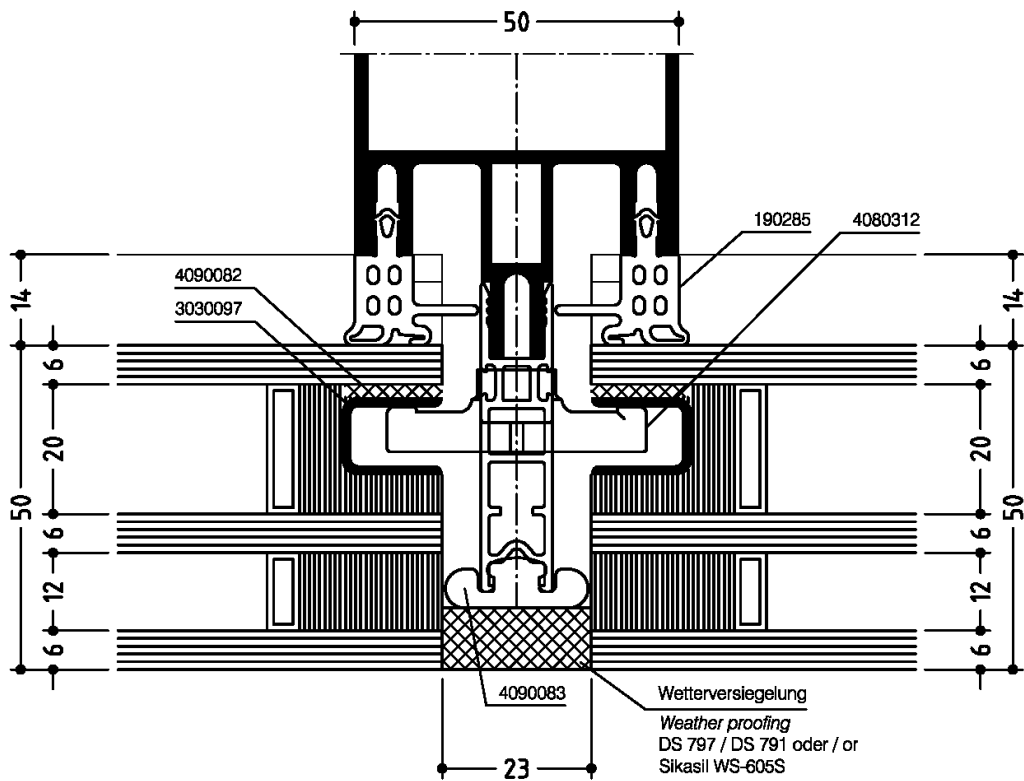

WICTEC 50SG

Glaselement Glass unit

Glasdicke gemäß den
statischen Anforderungen.

Glass thickness according to
statical requirements.

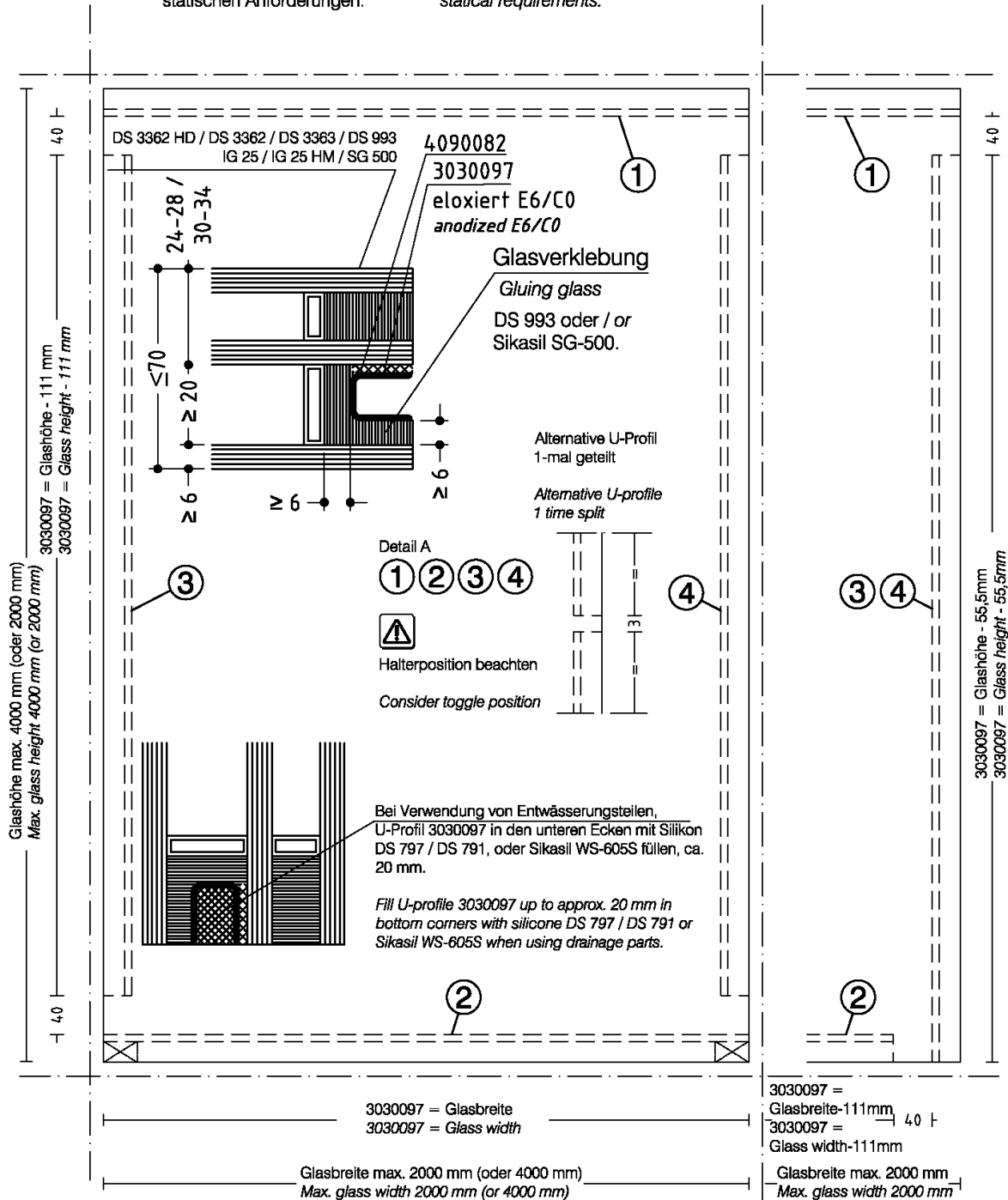

WICTEC 50SG = 1, 2, 3, 4

WICTEC 50SG = 1, 2
Semi-Fassade vertikal
Semi façade vertical

WICTEC 50SG = 3, 4
Semi-Fassade horizontal
Semi façade horizontal

WICTEC 50SG

Glaselement Glass unit

Glasdicke gemäß den
statischen Anforderungen.

Glass thickness according to
statical requirements.

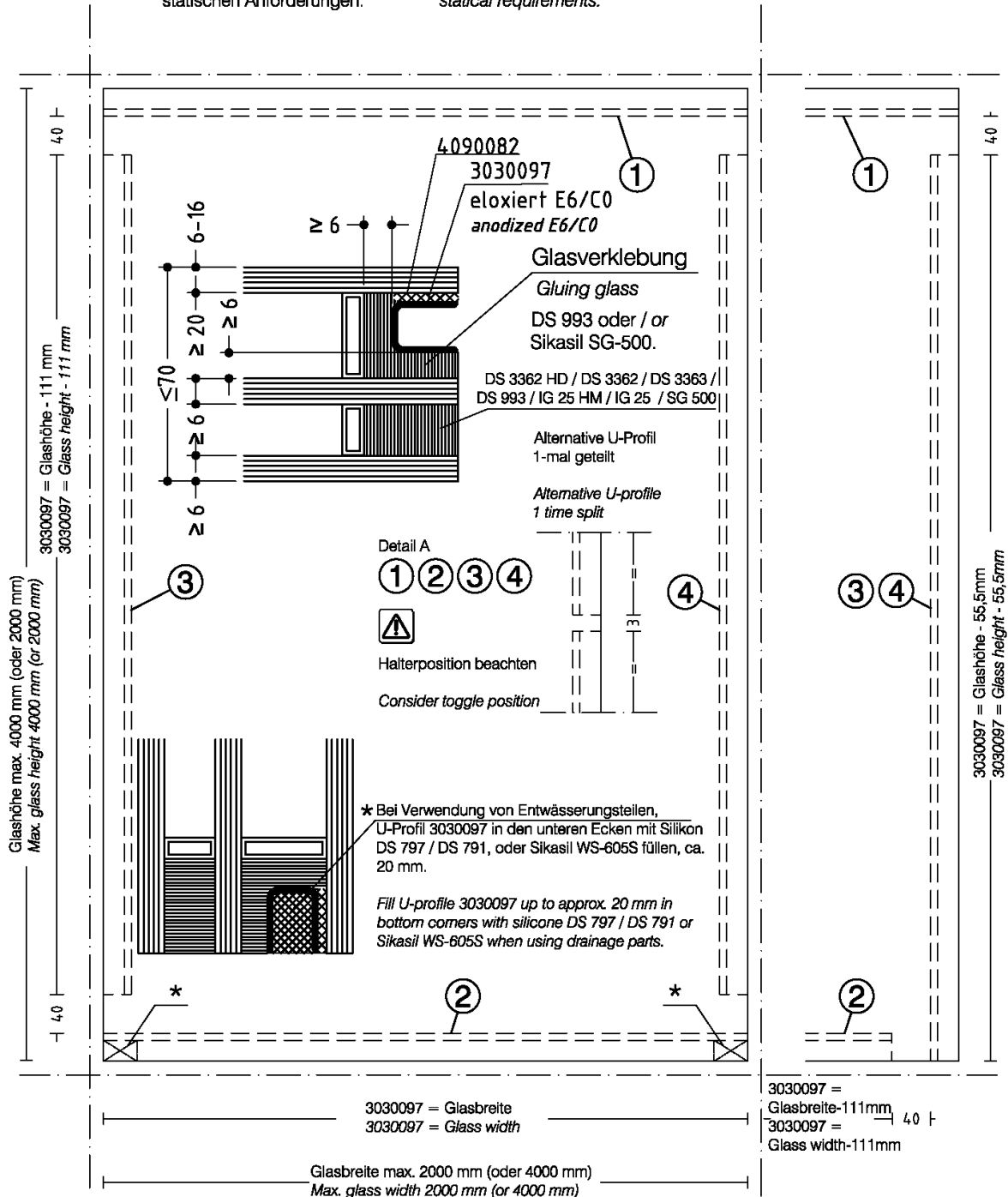

WICTEC 50SG = 1, 2, 3, 4

WICTEC 50SG = 1, 2
Semi-Fassade vertical

WICTEC 50SG = 3, 4
Semi-Fassade horizontal

Glassicherung
Glass safeguard

Technical Information

Anzahl der Glassicherung
entsprechend den Anforderungen
Fzul. = 1600 N/Glassicherung

The number of glass safeguards
according to requirements
Fadm. = 1600 N/ per safeguard

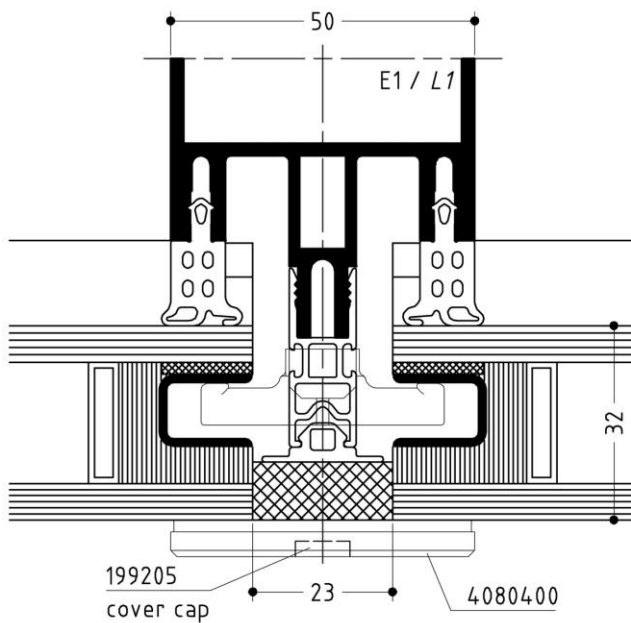
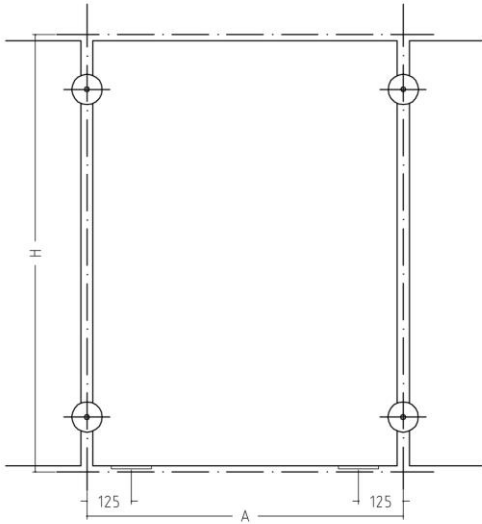

Füllungs- dicke Infill thickness	Glas- sicherung Glass safeguard	Scheibe Washer	Zylinderblechschr. ST5.5 T25 Tapping fillister head screw ST5.5 T25
32 34 36	4080400 + 199205	2 x 4040658	4070092 (41)
34 36 38	4080400 + 199205	1 x 4040658	4070092 (41)
36 38 40	4080400 + 199205	-	4070092 (41)
38 40 42	4080400 + 199205	2 x 4040658	4070093 (47)
40 42 44	4080400 + 199205	1 x 4040658	4070093 (47)
42 44 46	4080400 + 199205	-	4070093 (47)
44 46 48	4080400 + 199205	2 x 4040658	4070094 (53)
46 48 50	4080400 + 199205	1 x 4040658	4070094 (53)
48 50 52	4080400 + 199205	-	4070094 (53)
50 52 54	4080400 + 199205	2 x 4040658	4070095 (59)
52 54 56	4080400 + 199205	1 x 4040658	4070095 (59)
54 56 58	4080400 + 199205	-	4070095 (59)
56 58 60	4080400 + 199205	2 x 4040658	4070096 (65)
58 60 62	4080400 + 199205	1 x 4040658	4070096 (65)
60 62 64	4080400 + 199205	-	4070096 (65)
62 64 66	4080400 + 199205	2 x 4040658	4070097 (71)
64 66 68	4080400 + 199205	1 x 4040658	4070097 (71)
66 68 70	4080400 + 199205	-	4070097 (71)

WICONA® SEC-000042160
DOC-0000824810

25.07.2012

Annex 7

Einbau Vorklotz und Glashalter
 Assembly of glazing shim and glass holder

Construction point

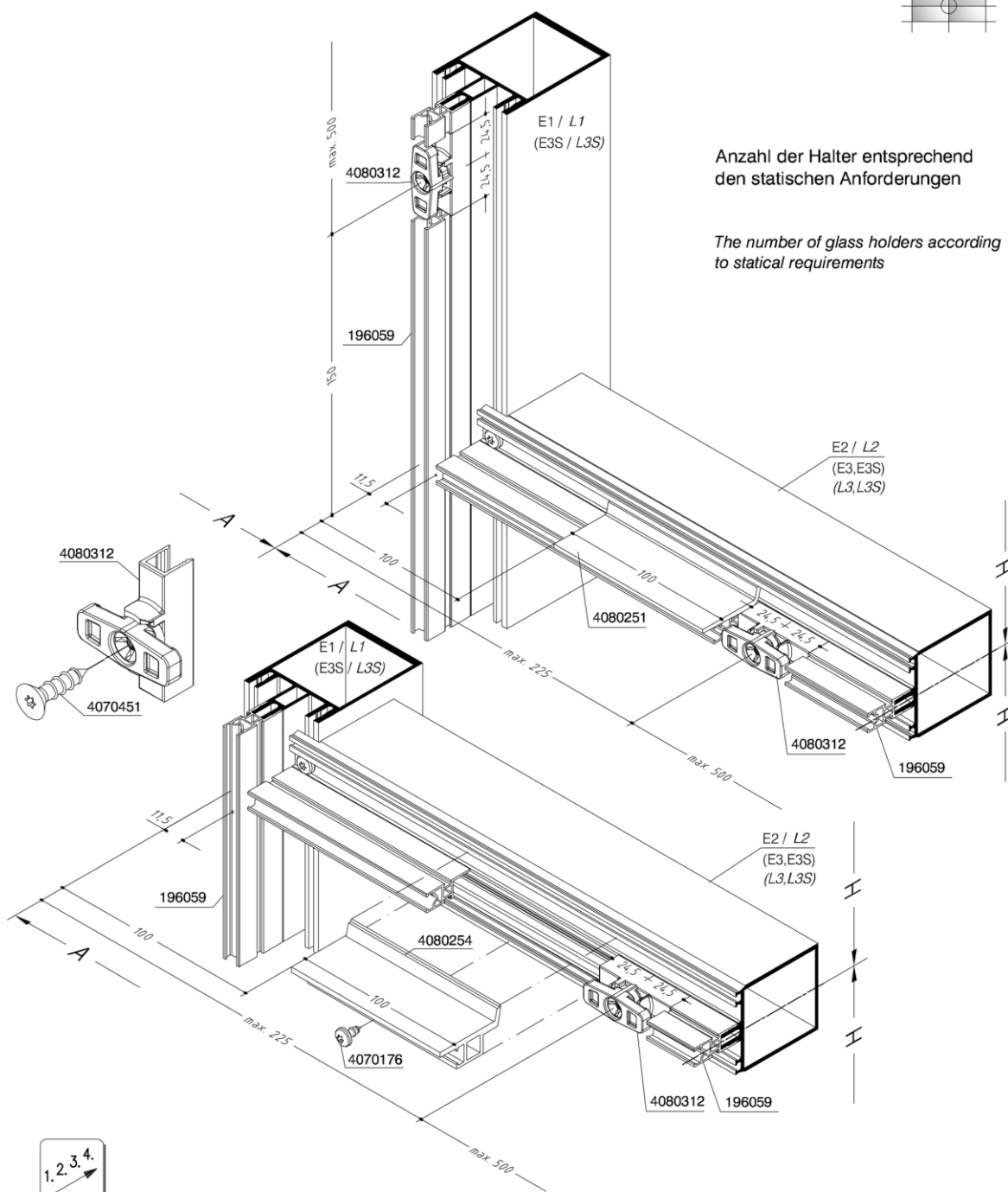
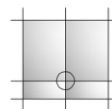

Anzahl der Halter entsprechend den statischen Anforderungen

The number of glass holders according to static requirements



- Montage Halter 4080312.
- Zuschnitt Dämmleiste 196059.
- Montage Vorklotz 4080251.
- Mounting glass holder 4080312.
- Cutting thermal break profile 196059.
- Mounting glazing shim 4080251.

WICONA® SEC-000038782 REV. A 25.07.2012
 DOC-0000705321

Annex 8

Einbau übergreifender Vorklotz
 Assembly of comprehensive glass support

Construction point

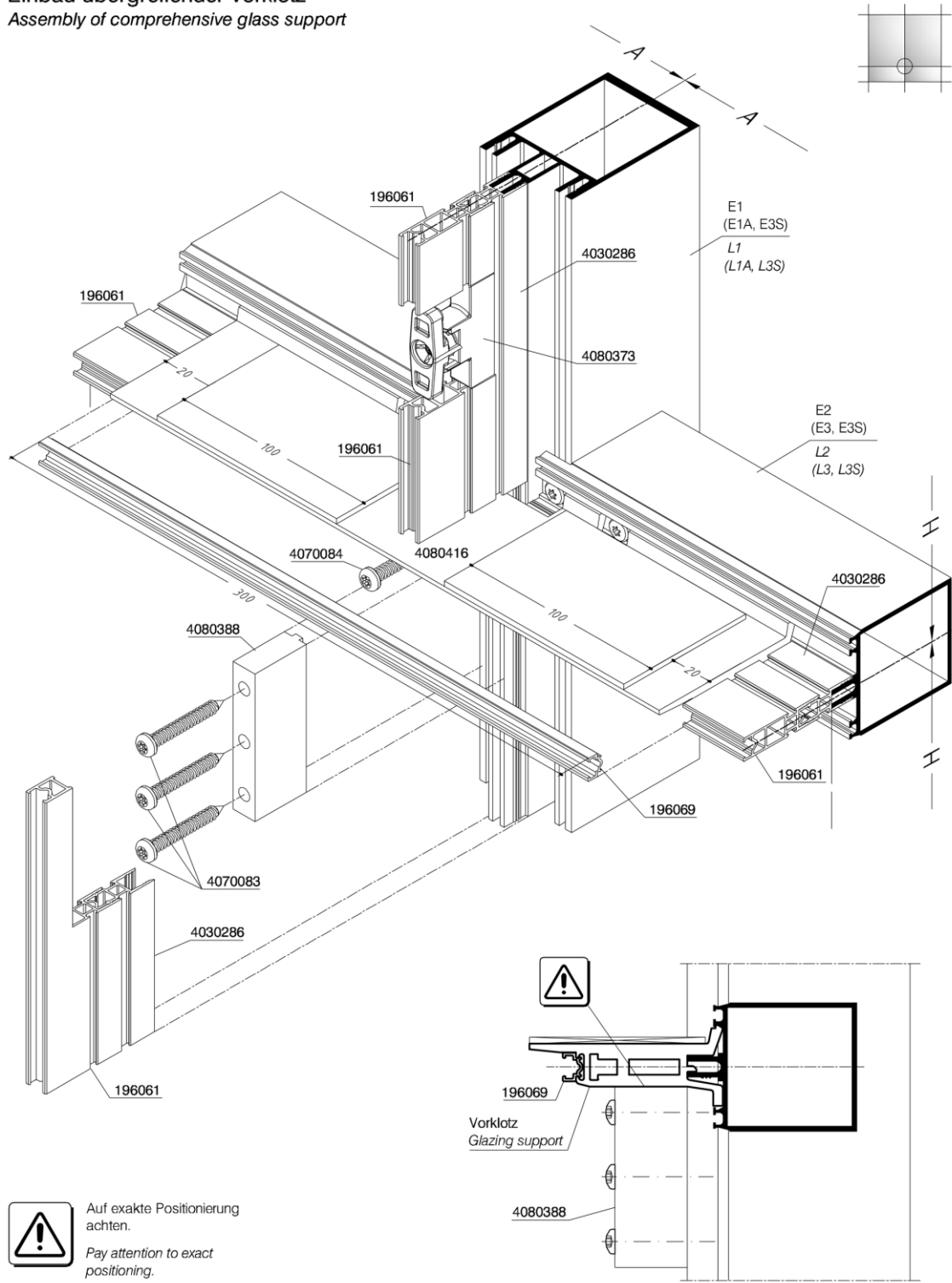

 Auf exakte Positionierung achten.
 Pay attention to exact positioning.

WICONA® DOC-0000843766 REV. A 25.07.2012
 SEC-000042797

Annex 8.1

Einbau übergreifender Vorklotz
 Assembly of comprehensive glass support

Einseitige Anwendung
 One - sided application

Construction point

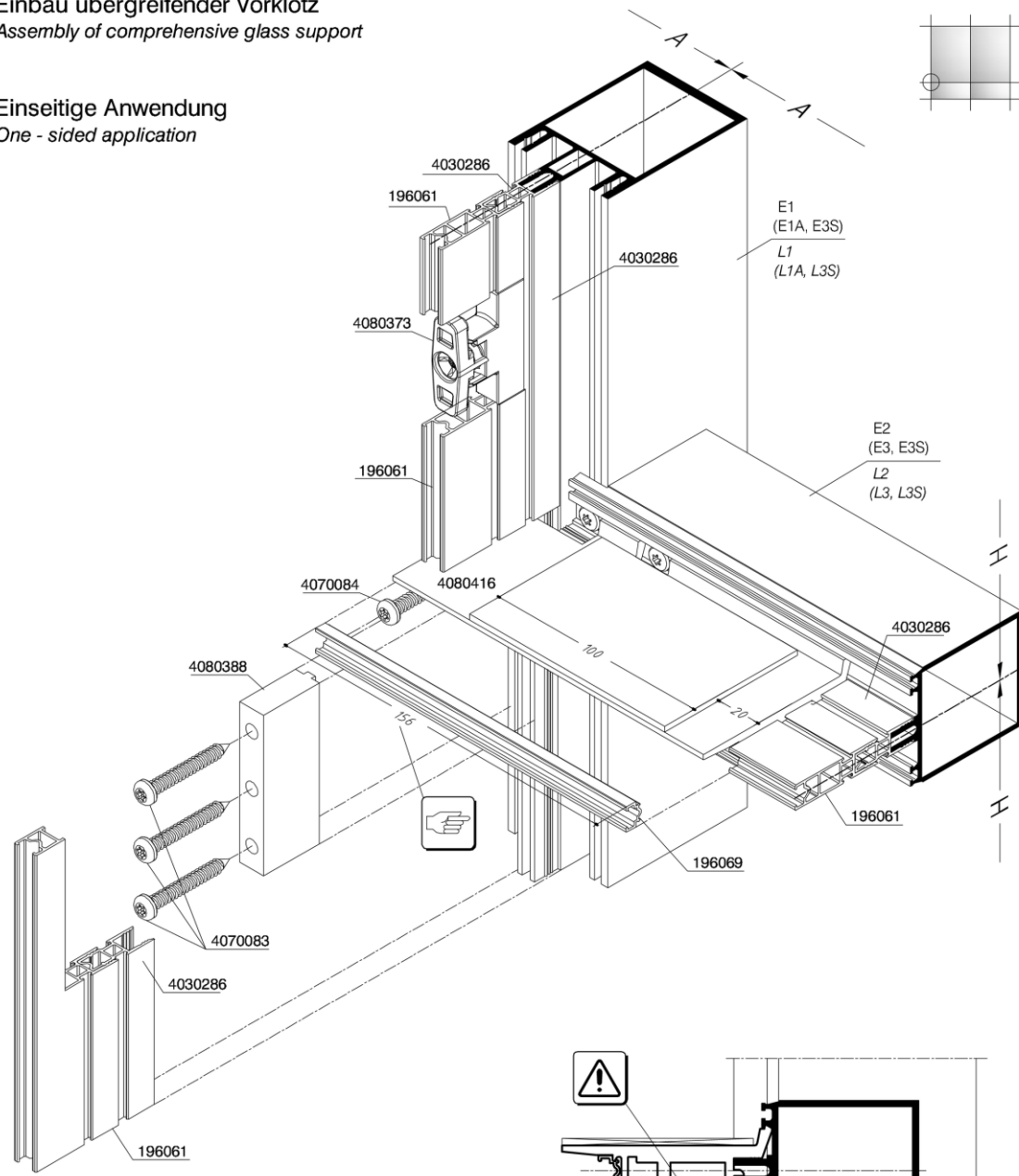

Für einseitige Anwendung
 Vorklotz besäumen.
 Cut to size shim for
 one - sided application.



Auf exakte Positionierung
 achten.
 Pay attention to exact
 positioning.

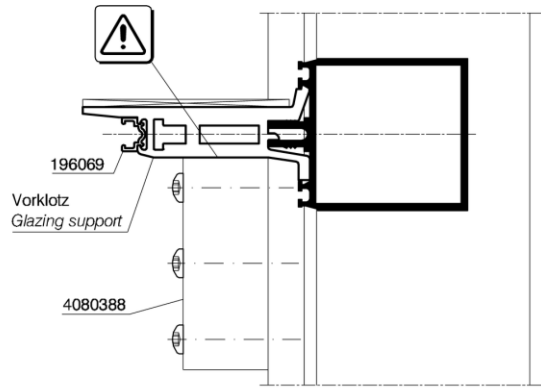

WICONA® DOC-0000843890 REV. A 25.07.2012
 SEC-000042790

Annex 8.2

in WICTEC 50SG
in WICTEC 50SG

Construction section

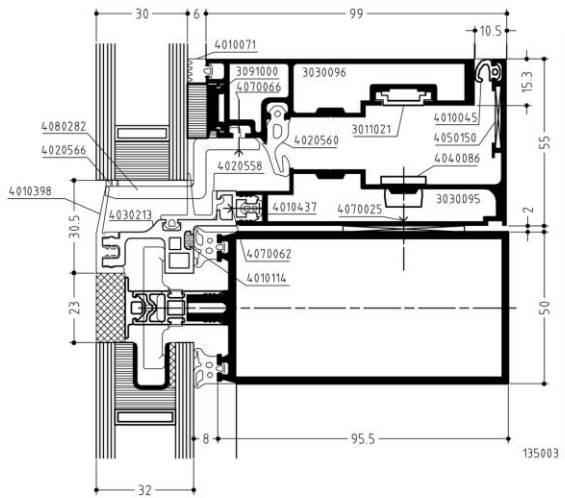
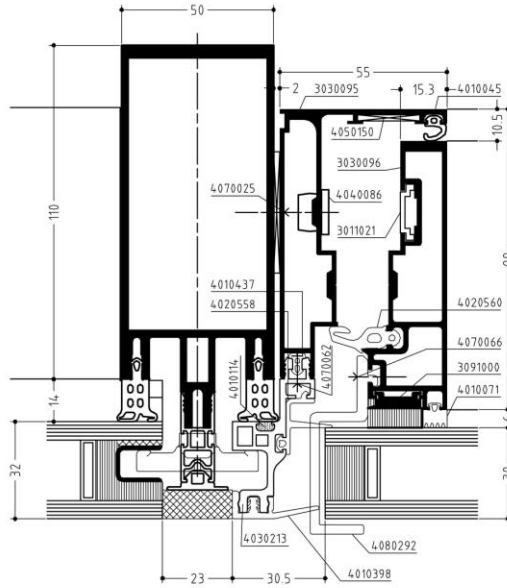
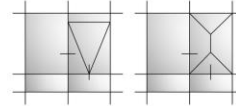

WICONA® SEC-000039362 REV. B 25.07.2012
DOC-0000729396

Annex 9

in WICTEC 50SG
in WICTEC 50SG

Construction section

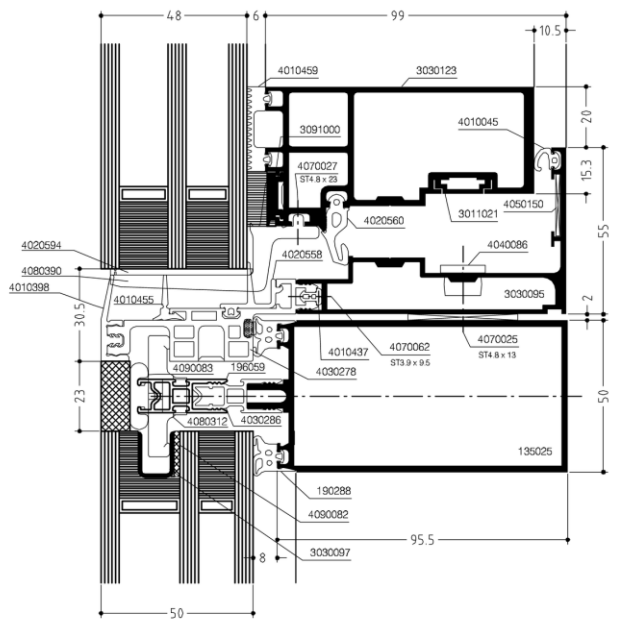
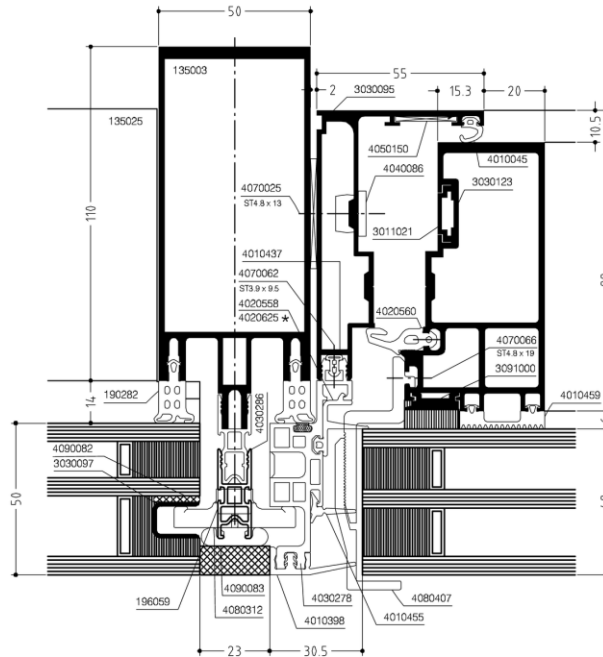
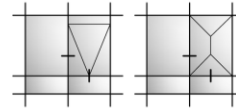

WICONA® DOC-0000824825 REV. A 25.07.2012
SEC-000042169

Annex 9.1

in WICTEC 50SG
in WICTEC 50SG

Construction section

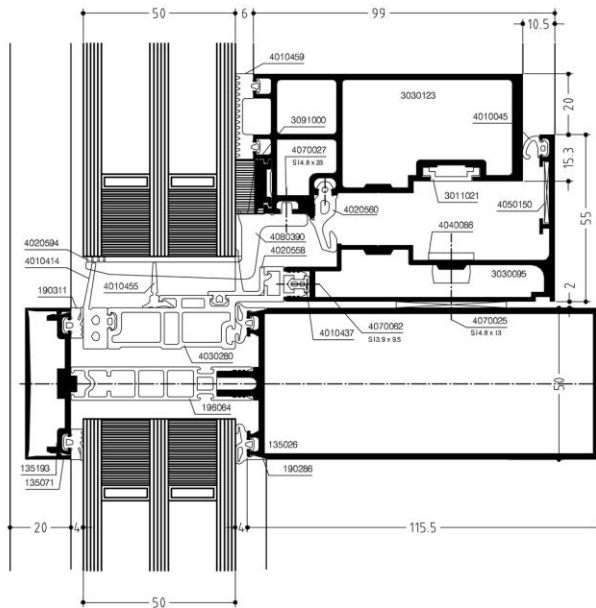
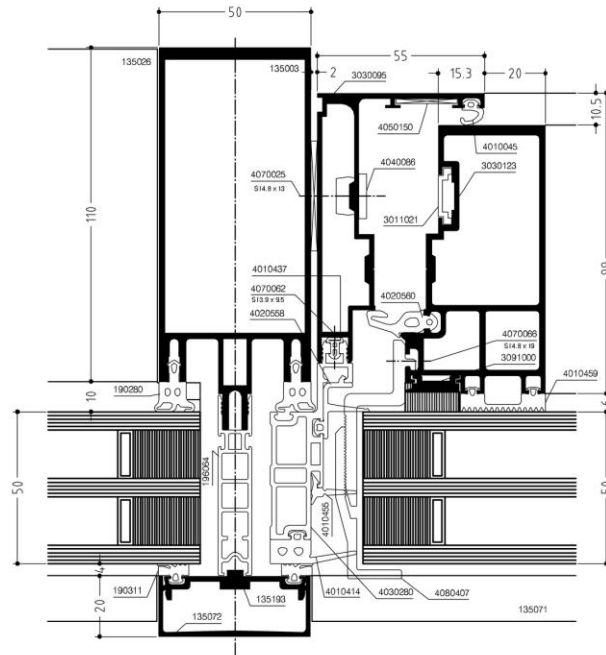
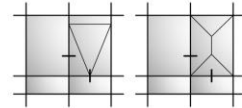

WICONA® DOC-0000824917 REV. A 25.07.2012
SEC-000042171

Annex 10.1

WICLINE 90SG

Glaselement
Glass unit

Verklebung
Gluing

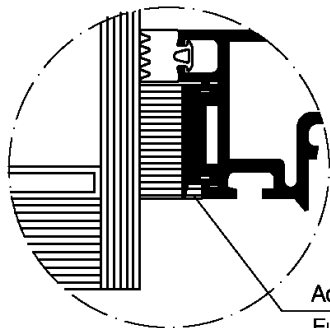
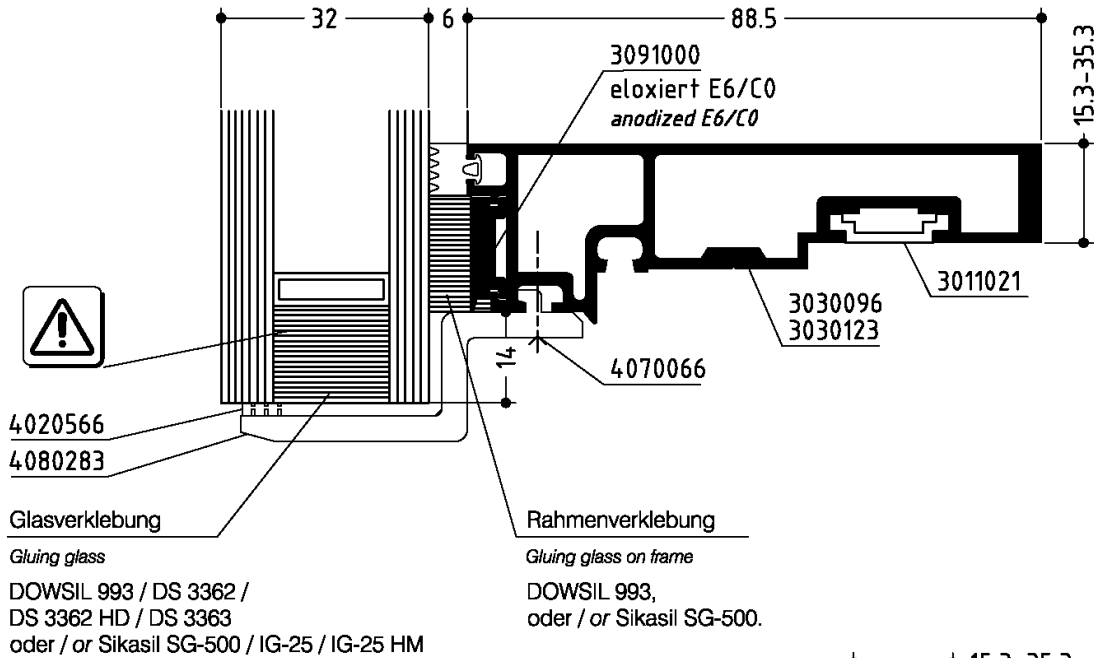

Achtung !
Fuge versiegeln
Attention !
Seal groove

Vorklotz und Sicherungshalter nach dem Verkleben sofort wieder einbauen!
Mount glazing shim and safety glass holder immediately after gluing!



Die Fugendimensionierung erfolgt durch den Isolierglashersteller.
The dimensioning of groove is done by the insulation glass manufacturer.

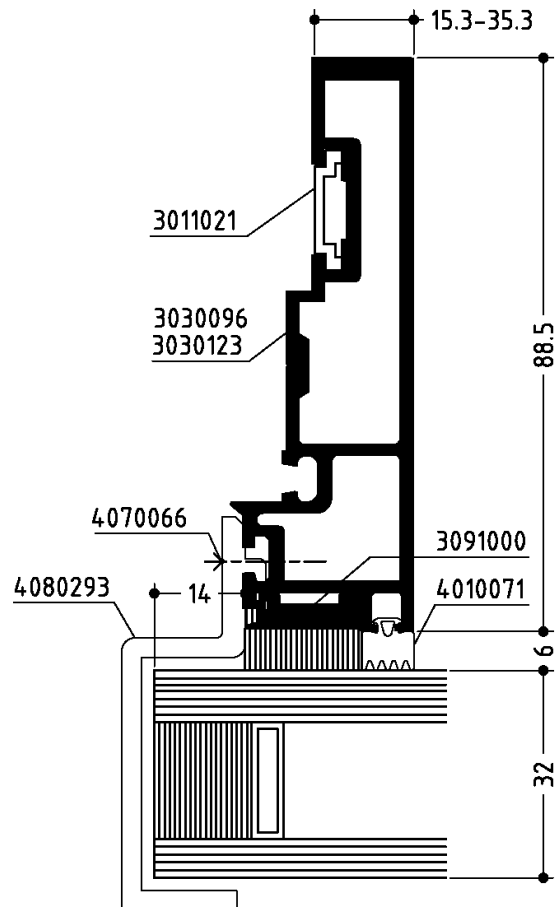

WICLINE 90SG

Verklebung
Gluing

Technische Information
Technical Information

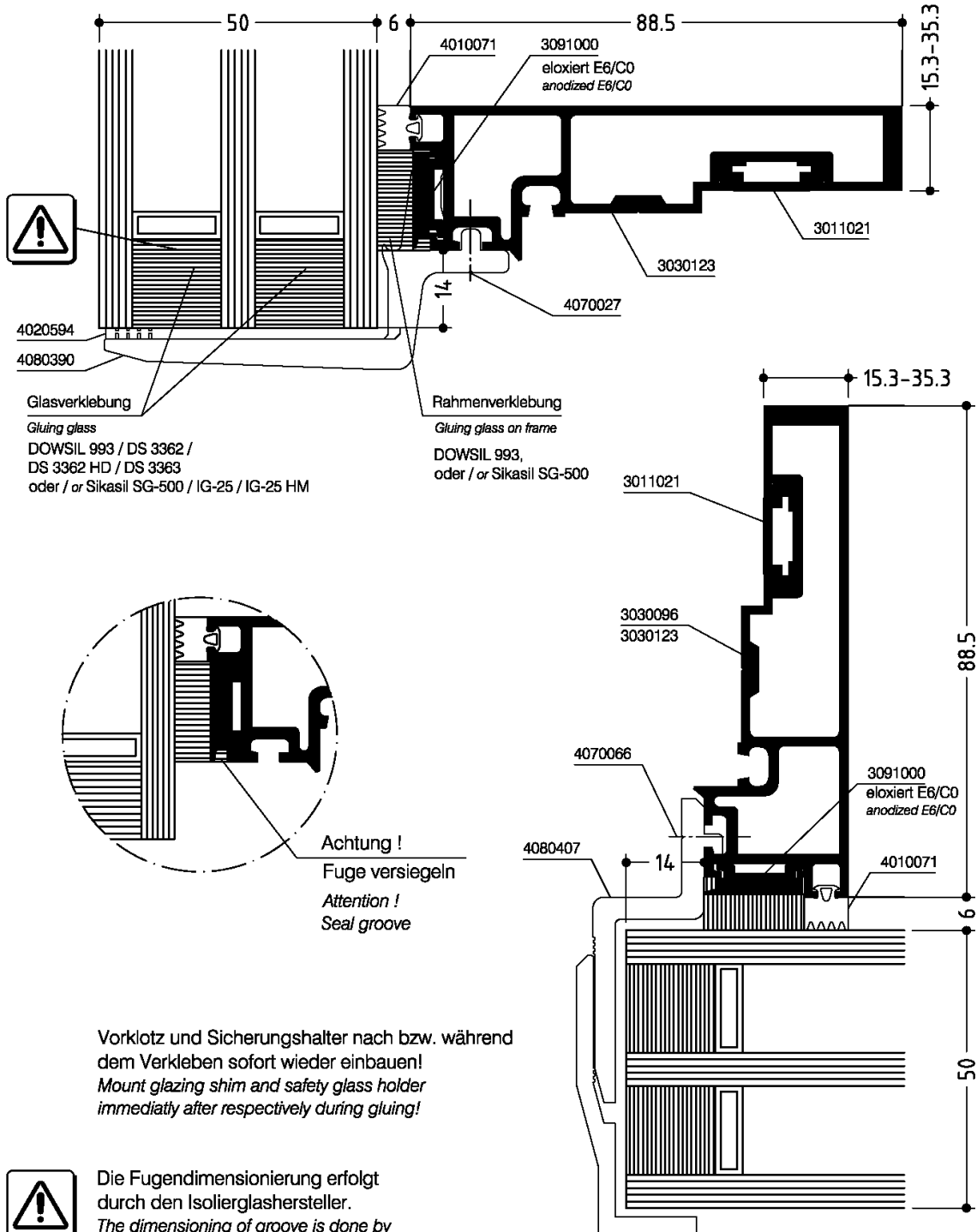

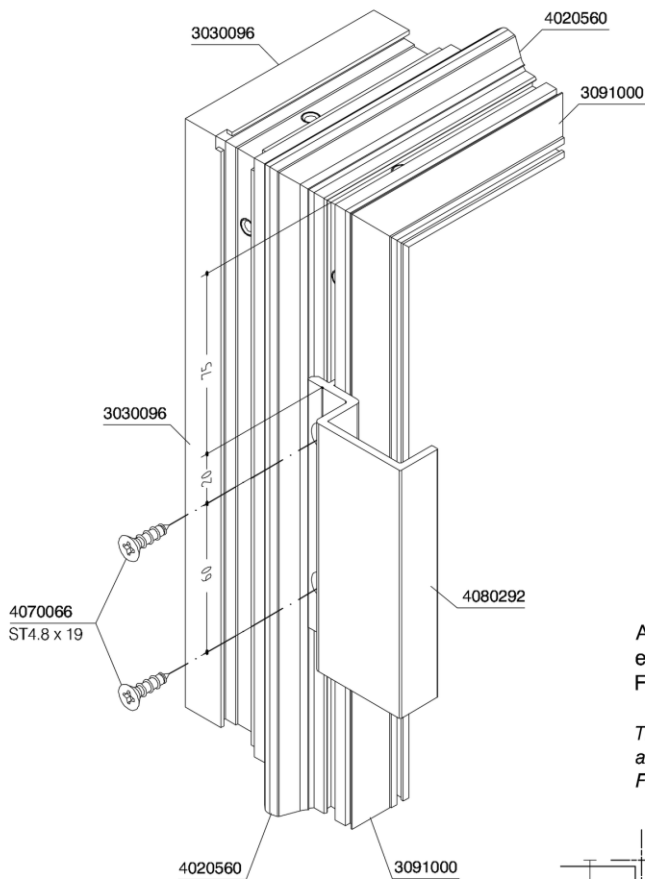
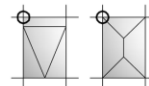

Bohren
 Drilling
 Ø4.2 mm

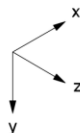

Anzahl der Glassicherung
 entsprechend den Anforderungen
 Fzul. in z Richtung = 1200 N

The number of glass safeguards
 according to requirements
 Fadm. in z direction = 1200 N

Blendrahmendichtung, im Bereich
 der Glassicherung einschneiden.
 Cut frame gasket, in the
 area of glass safeguard.

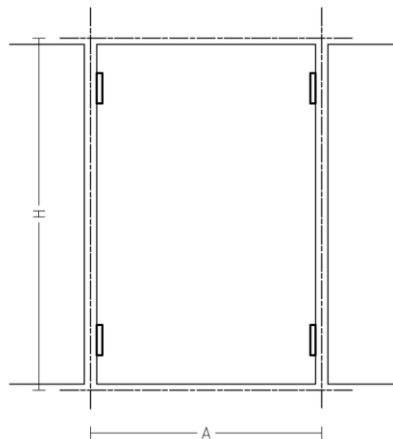

Glassicherung / Glass safeguard

Construction point

Für Füllungsdicke ≥ 46 mm
 For Infill thickness ≥ 46 mm

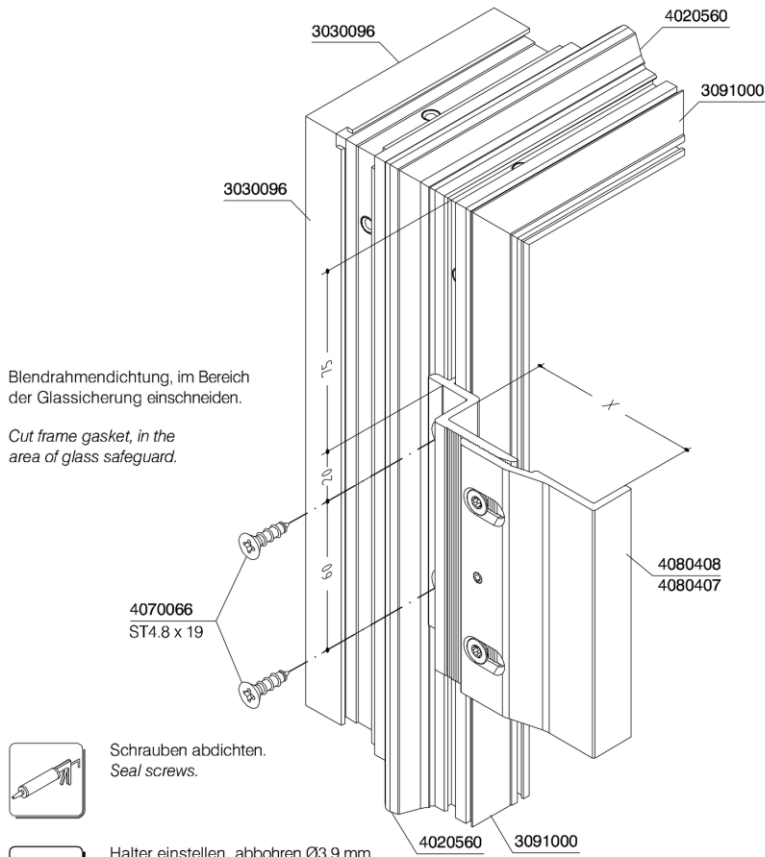
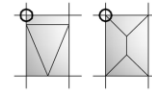

Blendrahmendichtung, im Bereich der Glassicherung einschneiden.
 Cut frame gasket, in the area of glass safeguard.



Schrauben abdichten.
 Seal screws.



Halter einstellen, abbohren $\varnothing 3,9$ mm und Stift setzen.
 Adjust holder, drill out $\varnothing 3,9$ mm, and set pin.
 Adjustment dimension $X = \text{Infill thickness} + 4$ mm.



Bohren
 $\varnothing 4,2$ mm
 Drilling



Bohrschablone
 5010585
 Drilling template

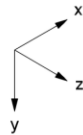

Anzahl der Glassicherung entsprechend den Anforderungen
 Fzul. in z Richtung = 1200 N

The number of glass safeguards according to requirements
 Fadm. in z direction = 1200 N

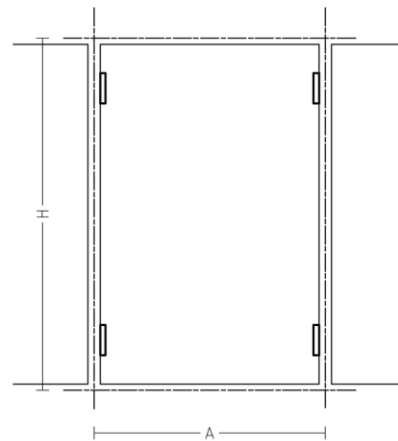
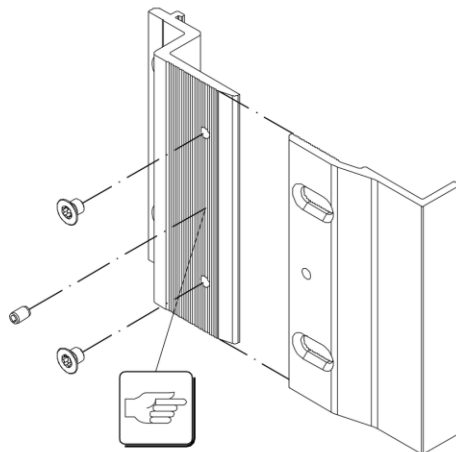

WICONA® SEC-000042173 REV. A 25.07.2012
 DOC-0000824950

Annex 12.1

Montage Vorklotz / Mounting glazing shim

Construction point

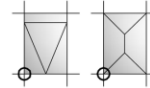

Bohren
 Ø4.2 mm
 Drilling



Vor montieren des Vorklotzes,
 Silikonvorklotz 4020566 auf-
 kleben und auf entsprechendes
 Maß kürzen.

Glue silicone shim 4020566
 on aluminium glazing shim
 and shorten to the appropriate
 dimension prior to mounting.

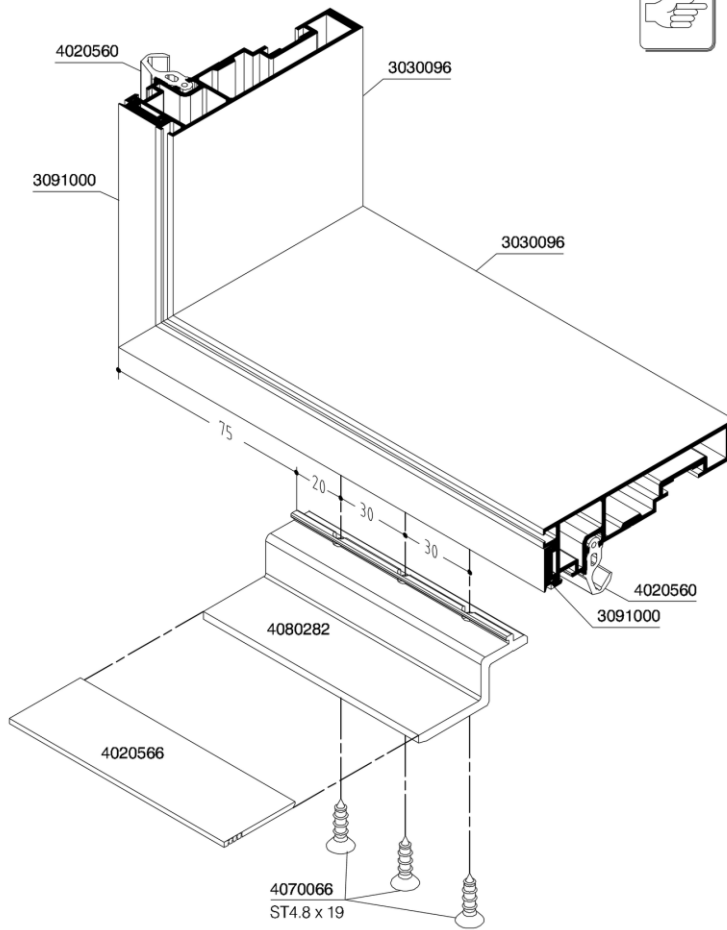

Montage Vorklotz / Mounting glazing shim

Construction point

Für Füllungsdicke ≥ 44 mm
For Infill thickness ≥ 44 mm

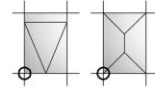

Bohren
 $\varnothing 4.2$ mm
Drilling



Bohrschablone
5010585
Drilling template



Vor montieren des Vorklotzes,
Silikonvorklotz 4020595 auf-
kleben und auf entsprechendes
Maß kürzen.

Glue silicone shim 4020595
on aluminium glazing shim
and shorten to the appropriate
dimension prior to mounting.

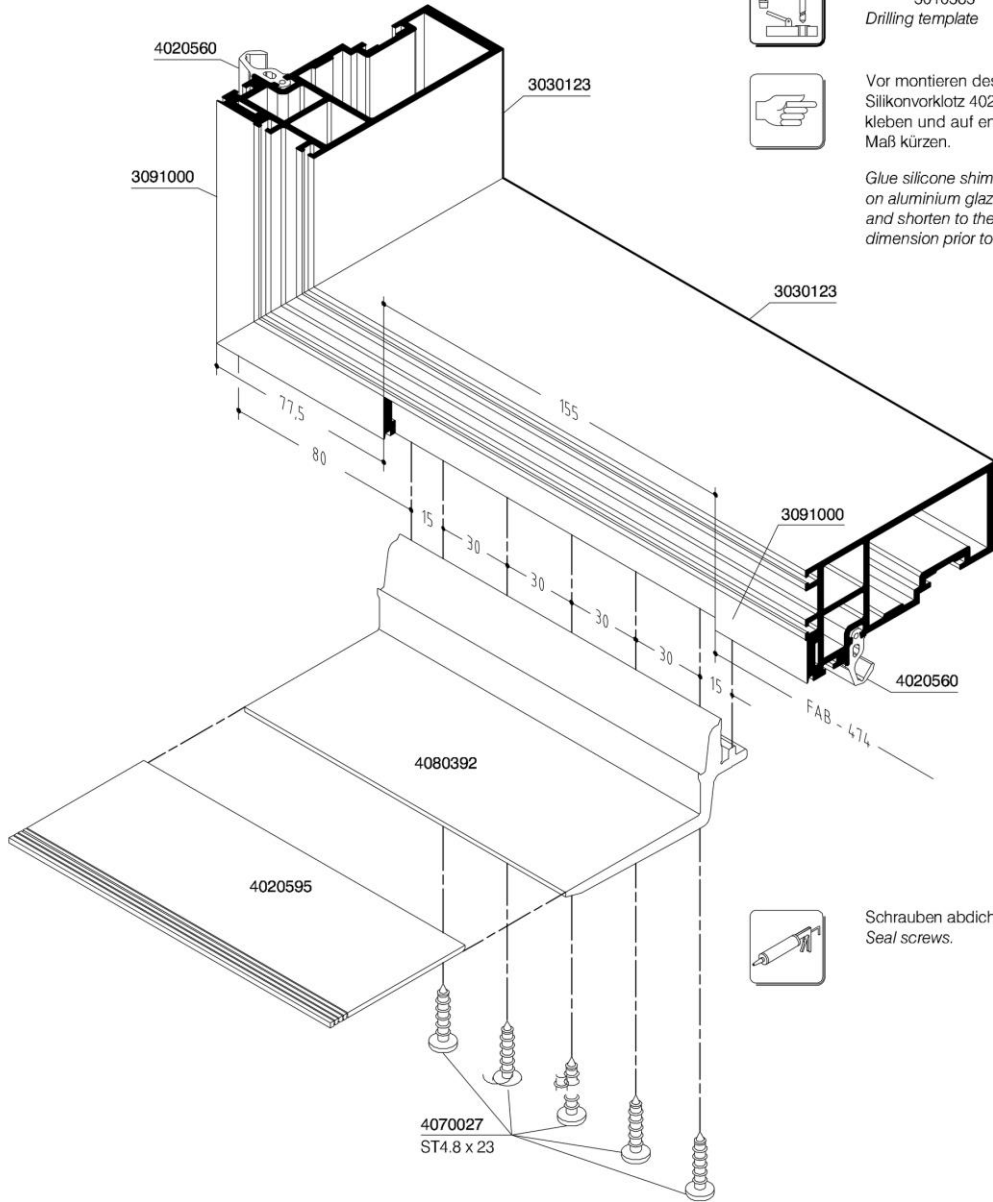

Schrauben abdichten.
Seal screws.