

EUROPEAN TECHNICAL ASSESSMENT

ETA 16/0663
Version 03
Date of issue: 2018-11-16



UBAtc Assessment Operator:
Belgian Construction Certification Association
Rue d'Arlon 53 - 1040 Brussels
www.bcca.be - info@bcca.be



Technical Assessment Body issuing the European Technical Assessment: UBAtc.
UBAtc has been designated according to Article 29 of Regulation (EU) No 305/2011
and is member of EOTA (European Organisation for Technical Assessment)

Trade name of the
construction product:

Kedge Fall Arrest

Product family to which the
construction product belongs:

33 - Fixings

Manufacturer:

Kedge Safety Systems
Postbus 850
NL - 4200 AW Gorinchem

Manufacturing plant(s):

Kedge Safety Systems
Stephensonweg 2
NL - 4207 HB Gorinchem

Website:

www.kedge.nu

This European Technical
Assessment is issued in
accordance with Regulation
(EU) No 305/2011, on the basis
of:

European Assessment Document (EAD) :

EAD 330340-00-0606: "Factory made structural anchor for
attaching personal fall protection equipment, designed to
be permanently and fully bonded to a multi-layered roof
waterproofing system"

This version replaces:

ETA 16/0663, issued on 25 June 2018

This European Technical
Assessment contains:

12 pages, including 3 annexes, which form an integral part
of the document



**European Organisation
for Technical Assessment**

Legal bases and general conditions

- 1 This European Technical Assessment is issued by UBAtc (Union belge pour l'Agrément technique de la construction, i.e. Belgian Union for technical Approval in construction), in accordance with:
 - Regulation (EU) No 305/2011¹ of the European Parliament and of the Council of 9 March 2011 laying down harmonised conditions for the marketing of construction products and repealing Council Directive 89/106/EEC
 - Commission Implementing Regulation (EU) No 1062/2013² of 30 October 2013 on the format of the European Technical Assessment for construction products
 - European Assessment Document (EAD): EAD 330340-00-0606.
- 2 Under the provisions of Regulation (EU) No 305/2011, UBAtc is not authorized to check whether the provisions of this European Technical Assessment are met once the ETA has been issued.
- 3 The responsibility for the conformity of the performances of the products with this European Technical Assessment and the suitability of the products for the intended use remains with the holder of the European Technical Assessment.
- 4 Depending on the applicable Assessment and verification of constancy of performance (AVCP) system, (a) notified body(ies) may carry out third-party tasks in the process of assessment and verification of constancy of performance under this Regulation once the European Technical Assessment has been issued.
- 5 This European Technical Assessment allows the manufacturer of the construction product covered by this ETA to draw up a declaration of performance for the construction product.
- 6 CE marking should be affixed to all construction products for which the manufacturer has drawn up a declaration of performance.
- 7 This European Technical Assessment is not to be transferred to other manufacturers, agents of manufacturers, or manufacturing plants other than those indicated on page 1 of this European Technical Assessment.
- 8 The European Technical Assessment holder confirms to guarantee that the product(-s) to which this assessment relates, is/are produced and marketed in accordance with and comply with all applicable legal and regulatory provisions, including, without limitation, national and European legislation on the safety of products and services. The ETA-holder shall notify the UBAtc immediately in writing of any circumstance affecting the aforementioned guarantee. This assessment is issued under the condition that the aforementioned guarantee by the ETA-holder will be continuously observed.
- 9 According to Article 11(6) of Regulation (EU) No 305/2011, when making a construction product available on the market, the manufacturer shall ensure that the product is accompanied by instructions and safety information in a language determined by the Member State concerned which can be easily understood by users. These instructions and safety information should fully correspond with the technical information about the product and its intended use, which the manufacturer has submitted to the responsible Technical Assessment Body for the issuing of the European Technical Assessment.
- 10 Pursuant to Article 11(3) of Regulation (EU) No 305/2011, manufacturers shall adequately take into account changes in the product-type and in the applicable harmonised technical specifications. Therefore, when the contents of the issued European Technical Assessment do not any longer correspond to the product-type, the manufacturer should refrain from using this European Technical Assessment as the basis for their declaration of performance.
- 11 All rights of exploitation in any form and by any means of this European Technical Assessment is reserved for UBAtc and the ETA-holder, subject to the provisions of the applicable UBAtc regulations.
- 12 Reproduction of this European Technical Assessment including transmission by electronic means shall be in full. However, partial reproduction can be made with the written consent of UBAtc. In this case, partial reproduction has to be designated as such. Texts and drawings of advertising brochures shall not contradict or misuse the European Technical Assessment.
- 13 Subject to the application introduced, this European Technical Assessment is issued in English and may be issued by the UBAtc in its official languages. The translations correspond fully to the English reference version circulated in EOTA.
- 14 Verification and assessment in the framework of this ETA, has been performed on samples representative for the factory made structural anchors, unless otherwise specified.
- 15 This European Technical Assessment was first issued by UBAtc on 23 April 2018. The 2nd version, issued on 25 June 2018, took into account Commission Delegated Decision (EU) 2018/771³ and comprised an additional annex, Annex II. This 3rd version, issued on 16 November 2018, includes editorial changes, taking into account the version of the EAD, cited in the Official Journal of the European Union on 16 November 2018⁴.

¹ OJEU, L 88, 2011/04/04

² OJEU, L 289, 2013/10/31

³ OJEU, L129, 2018/05/25

⁴ OJEU, C417/07, 2018/11/16

Technical Provisions

1 Technical description of the product

1.1 General

This ETA is being issued for the products specified on the cover page on the basis of agreed data/information, deposited with the UBAtc, which identifies the products that have been assessed.

Changes to the product/production process, which could result in the deposited data/information being incorrect, should be notified to the UBAtc before the changes are introduced. The UBAtc will decide whether or not such changes affect the ETA and consequently the validity of the CE marking on the basis of the ETA and if so whether further assessment/alterations to the ETA, shall be necessary

1.2 Description of the construction product

This European Technical Assessment specifies a factory made structural anchor for attaching personal fall protection equipment, designed to be permanently fully bonded by thermal welding to a multi-layered modified bitumen roof waterproofing system provided with polyester reinforcement to a maximum roof slope of 15°, without perforating the roof waterproofing system.

In this ETA, the above described anchor will be referred to as "structural anchor".

The build-up of the structural anchor is given in this ETA, clause 3.4.1.

Ancillary products referred to in this ETA, as a part of installation provisions or in the framework of determining performances, are not covered by the ETA and therefore, those ancillary products cannot be CE-marked on the basis of it.

2 Specification of the intended use(s) in accordance with the applicable EAD

2.1 Intended uses

The intended use of the factory made structural anchor is to attach personal fall protection equipment to form a fall arrest system as defined in EN 363:2008, clause 3.2.1.1.

The end use temperature categories for which the structural anchor has been assessed are, in accordance with EAD 330340-00-0606, clauses 2.2.4.2 and 2.2.4.3:

- Low temperature category (TL):
"Extreme low temperature" - 30 °C
- High temperature category (TH):
"Extreme high temperature" 90 °C

The structural anchor as defined in this ETA, clause 1.2, is applicable to the following methods of attaching of a multi-layered modified bituminous roof waterproofing system to the deck/substructure in accordance to EAD 330340-00-0606, clause 1.2.1:

- Mechanically fastened (MF), with a minimum of 3 fasteners per m²;
- Loose laid and ballasted (L), minimum gravel ballast of 40 mm thick (approximately 60 kg/m²);
- Partially bonded top layer (P), with a minimum percentage of bonding surface of 50 % of the total area, on a mechanically fastened modified bituminous roof waterproofing system.

The structural anchor may be used on new or on existing multi-layered modified bituminous roof waterproofing systems, provided that:

- The multi-layered modified bituminous roof waterproofing system contains a polyester reinforcement;
- The minimum value of the maximum tensile force of the new or existing multi-layered modified bituminous roof waterproofing system shall be:
 - In case of the attaching method L: system at least 670 N/50mm.
 - In case of the attaching method MF: system at least 925 N/50mm
 - In case of the attaching method P: top layer at least 560 N/50mm
- For existing roofs the minimum thickness of the top layer of the multi-layered modified bituminous roof waterproofing system shall either be:
 - In case of bonding by thermal welding, at least:
 - 3,0 mm for non-granulated top layers; or
 - 3,5 mm for granulated top layers (total thickness).
 - In case of bonding with hot bitumen at least:
 - 2,0 mm for non-granulated top layers; or
 - 2,5 mm for granulated top layers (total thickness).

2.2 Working life/Durability

The provisions specified in this European Technical Assessment have been written, based on the manufacturer's request to take into account a working life of concrete incorporating the factory made "structural anchor" for fall arrest, for the intended use of 10 years when installed in the works, provided that the factory made structural anchor is subject to appropriate installation, see this ETA, clause 2.3.2. These provisions are based upon the current state of the art and the available knowledge and experience.

When assessing the product, the intended use as foreseen by the manufacturer shall be taken into account. The real working life may be, in normal use conditions, considerably longer without major degradation affecting the basic requirements for works⁵.

⁵ The real working life of a product incorporated in a specific work depends on the environmental conditions to which that work is subject, as well as on the particular conditions of the design, execution, use and maintenance of that works. Therefore, it cannot be excluded that in certain cases the real working life of the product may also be shorter than the working life referred to above.

The indications given as to the working life of the construction product cannot be interpreted as a guarantee neither given by the product manufacturer or his representative nor by the Technical Assessment Body issuing this ETA, but are regarded only as a means for expressing the expected economically reasonable working life of the product.

If a fall has been arrested, the structural anchor shall always be fully replaced according to the manufacturer's instructions.

2.3 Assumptions under which the fitness of the product(s) for the intended use was favourably assessed

2.3.1 Manufacturing directives

The European technical assessment is issued for the products on the basis of agreed data/information, deposited with the UBAtc, which identifies the product that has been assessed. Changes to the product or production process, which could result in this deposited data/information being incorrect, should be notified to the UBAtc before the changes are introduced. The UBAtc will decide whether such changes affect the ETA.

2.3.2 Recommendations regarding packaging, handling, installation and maintenance

With regard to product packaging, transport, storage, maintenance, replacement and repair it is the responsibility of the manufacturer to undertake the appropriate measures and to advise his clients on the transport, storage, maintenance, replacement and repair of the product as he considers necessary.

It is assumed that the product shall be installed according to the manufacturer's instructions.

The existing multi-layered modified bituminous roof waterproofing system shall be assessed on visual defects within the minimum roof size area before installation of the structural anchor. The following criteria apply: there shall be no visual defects such as:

- Cracks and/or tears in the bitumen top sheet;
- Delamination of the bitumen top coating from the reinforcement of the bitumen top sheet;
- (Partial) delamination of seams;
- Severe cracking of the top coating, reaching the reinforcement of the bitumen top sheet;
- Signs of delamination between the bitumen top sheet and the bitumen lower sheet.

The maximum tensile force of the new or existing multi-layered modified bituminous roof waterproofing system and the thickness of the top layer shall be assessed before installation of the structural anchor.

This shall be done by using the longitudinal tensile strength of the reinforced bituminous membranes according to EN 13707. The values of the longitudinal tensile strength for the individual polyester reinforced bituminous membranes, as used in the multi-layered modified bituminous roof waterproofing system, shall be summed together to a total maximum tensile force of the roof waterproofing system. Values for bituminous membranes, reinforced with glass fibres only, shall not be added.

The maximum tensile force of the multi-layered modified bituminous roof waterproofing system may also be determined by testing the maximum tensile force, according to EN 12311-1.

3 Performance of the product and references to the methods used for its assessment

3.1 Mechanical resistance and stability (BWR1)

3.1.1 Strength of the assembly of steel components of the structural anchor

The strength of the assembly of steel components of the structural anchor was assessed according to the procedure as detailed in EOTA TR 036, clause I, Table 1 specifies the methods used and the results of the assessment of the strength of the assembly of steel components of the structural anchor.

Table 1. Assessment of the strength of the assembly of steel components of the structural anchor

<i>Test</i>	<i>Test method</i>	<i>Result</i>
Deformation test	<i>EOTA TR 036, clause I.4.2</i>	<i>Permanent deformation = 0 mm</i>
Dynamic test	<i>EOTA TR 036, clause I.4.3</i>	<i>Rigid mass is arrested and is held clearly from the ground, peak force: 9,68 kN</i>
Static test	<i>EOTA TR 036, clause I.4.3.4</i>	<i>Permanent deformation = 1 mm (19,36 kN)</i>

These results are in accordance with EN 795:2012, which states that no part of the anchor, intended to deform, shall demonstrate permanent deformation of more than 10 mm in the direction of loading after being tested.

3.1.2 Strength of the structural anchor on a multi-layered bituminous roof waterproofing system to be used in a fall arrest system

3.1.2.1 Small scale testing before and after thermal ageing

The strength of the structural anchor on a multi-layered modified bituminous roof waterproofing system before and after thermal ageing is assessed by small scale testing in accordance with EOTA TR 036, clause II.2.

The test specimens consist of a top layer of a multi-layered modified bituminous roof waterproofing system according to EOTA TR 036, clause II.2.2, on which the structural anchor is adhered.

The following properties have been assessed:

1. The maximum static force $F_{s,m}$, of the unaged test specimen.
2. The change in the maximum static force $\Delta s,1$ in %, after ageing of the top layer of the multi-layered modified bituminous roof waterproofing membrane.
The value is < 20 %
3. The change in the maximum static force $\Delta s,2$ in %, after ageing of the combination of the structural anchor and the top layer of the multi-layered modified bituminous roof waterproofing membrane.
The value is < 20 %

3.1.2.2 Small scale testing at low temperature

The dynamic strength of the structural anchor on a multi-layered modified bituminous roof waterproofing system at low temperature has been assessed by small scale testing in accordance with EOTA TR 036, clause II.3.

Three test specimens have been tested at an extreme low temperature (TLFA) of -30 °C. The rigid mass was arrested and held clearly from the ground.

3.1.2.3 Full scale testing at high temperature

The effect of a load on the structural anchor on the strength of the multi-layered modified bituminous roof waterproofing system at high temperature has been assessed on large test specimens on a complete roof build-up using the combination of the structural anchor adhered to the multi-layered bituminous roof waterproofing system by full scale testing in accordance with EOTA TR 036, clause II.4.

The top layer of the roof was chosen in accordance with EOTA TR 036, clause II.4.2.

The chosen high temperature at fall arrest, THFA, is 90°C.

The following methods of attaching of a multi-layered modified bituminous roof waterproofing system to the deck/substructure were included in the assessment of the full scale testing at high temperature:

- Mechanically fastened (MF)
- Loose laid and ballasted (L)
- Partially bonded top layer (P)

The test specimens were in accordance with the provisions given in EAD 330340-00-0606, clause 2.2.4.3.

For all tested specimens, the rigid mass was arrested and the structural anchor holds the static force holding the mass clearly from the ground.

3.1.3 Strength of the structural anchor on a multi-layered bituminous roof waterproofing system to be used in a restraint system

Taking into account the intended use of the structural anchor, no performance was assessed.

3.1.4 Durability aspects

The assessment of durability is covered by the assessment methods of this ETA, clause 3.1.2. It concerns the ageing procedures that are taken into account in the assessment of these Essential Characteristics.

3.1.5 Minimum roof size

To avoid that the roof waterproofing system slides down, a minimum roof size is necessary. The minimum roof size has been assessed by analysis of the assumptions, test results and calculations in accordance to EAD 330340-00-0606, clause 2.2.6.

For mechanically fastened and partially bonded roof waterproofing systems, the minimum roof size is assessed to be hemispherical shaped with a radius of 2 m measured from the centre of the structural anchor.

For loose-laid and ballasted roof waterproofing systems, the minimum roof size is assessed to be hemispherical shaped with a radius of 1,75 m measured from the centre of the structural anchor.

3.2 Safety in case of fire (BWR2)

3.2.1 Reaction to fire

According to the Decision of the Commission 1996/603/EC⁶, the reaction to fire of the metal product components have been classified as class A1.

The flexible reinforced bituminous sheet components of the structural anchor have been classified in accordance with the provisions given in EAD 330340-00-0606, clause 2.2.8.2. Upper sheet: No performance assessed

3.3 Hygiene, health and the environment (BWR3) - Release of dangerous substances

3.3.1 SVOC and VOC

These products do not emit SVOC nor VOC

3.3.2 Leachable substances

No performance assessed

3.4 Properties and characteristics of assembly components

The determination of the properties of the build-up of the structural anchor and the individual metal components has been done in accordance to EAD 330340-00-0606, clause 2.2.7.

The determination of characteristics of the used flexible reinforced bituminous membranes has been performed by UBA⁶ in accordance with EAD 330340-00-0606, clause 2.2.8.

⁶ OJEU, L 267 of 1996/10/19, p. 23

Table 2. Characteristics of the flexible reinforced bituminous upper sheet of the structural anchor.

Characteristic	Test method	Units	Performance	
<i>Characteristics on unaged samples</i>				
Visible defects	EN 1850-1	-	No defects	
Dimensions	EAD 330340-00-0606, clause 2.2.8.2 EN 1848-1	mm	700 (-10, +0)	
		mm	3,5 (-0,2, +0,5)	
Reaction to fire	EN 13707:2013, clause 5.2.5.2	-	Class F	
Shear resistance of joints	EN 12317-1	N/50mm	≥ 500 (-0%, +50%)	
<i>Tensile properties</i>				
tensile force	EN 12311-1	N/50mm	longitudinal	900 (+-20%)
			transversal	750 (+-20%)
elongation	EN 12311-1	%	longitudinal	45 +-15
			transversal	55 +-15
Resistance to tearing (nail shank)	EN 12310-1	N	longitudinal	> 300
			transversal	> 250
Flexibility at low temperature (pliability)	EN 1109	°C	< -20 °C	
Flow resistance at elevated temperature	EN 1110	°C	> 100 °C	
Content, emission and/or release of dangerous substances	EAD 330340-00-0606, clause 2.2.2	-	see clause 3.3.1	
<i>Characteristics on aged samples (Ageing according to EN 1297)</i>				
Visible defects after artificial ageing	EN 1850-1	-	Pass	
Flexibility at low temperature (pliability)	EN 1109	°C	< -15 °C	
Flow resistance at elevated temperature	EN 1110	°C	> 100 °C	

3.4.1 Build-up of the structural anchor

The components of the assembled structural anchor are presented in Figure 1.

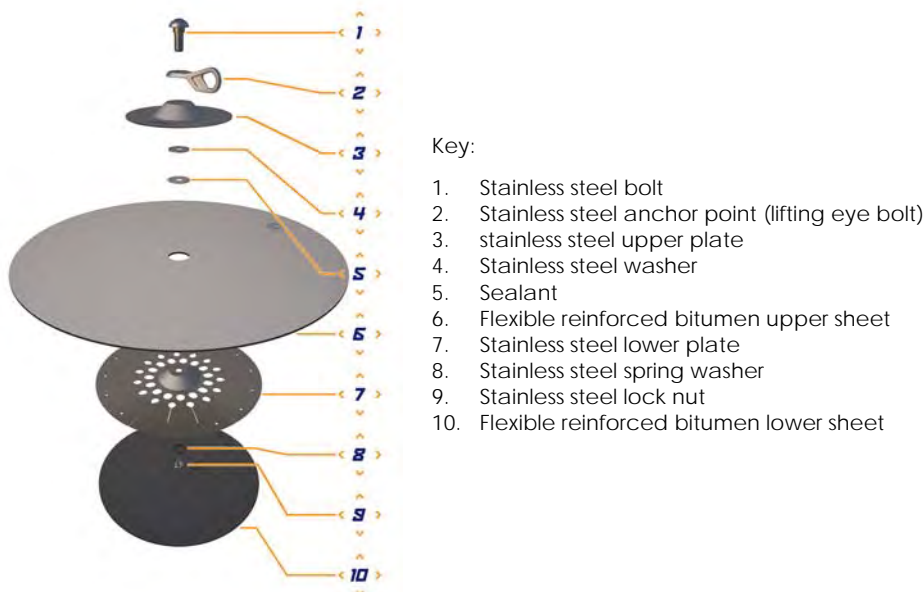

Figure 1 - Build-up of the assembled structural anchor

Table 3. Characteristics of the flexible reinforced bituminous lower sheet of the structural anchor.

Characteristic	Test method	Units	Performance
<i>Characteristics on unaged samples</i>			
Dimensions	EAD 330340-00-0606, clause 2.2.8.3 EN 1848-1	mm	430 (-10, +0)
		mm	4,0 (-0,2, +0,5)
Flow resistance at elevated temperature	EN 1110	°C	> 150 °C
Content, emission and/or release of dangerous substances	EAD 330340-00-0606, clause 2.2.2	-	see clause 3.3.1

3.4.2 Flexible reinforced bituminous sheets

The flexible reinforced bituminous upper sheet is circular with a diameter of 700 mm and nominal thickness of 3,5 mm.

The flexible reinforced bituminous lower sheet is also circular with a diameter of 435 mm and nominal thickness of 4 mm.

Both sheets comply with the provisions given in EAD 330340-00-0606, clause 2.2.8.

Tables 2 and 3 specify the characteristics of respectively the upper and lower sheets in accordance with the EAD 330340-00-0606, clauses 2.2.8.2 and 2.2.8.3 for the use in the structural anchor.

The above given characteristics are part of the information/data that was deposited to the RTAB for which the assessment has been performed.

3.4.3 Bolt, anchor-point, plates, spring washers and lock nut of stainless steel

3.4.3.1 Stainless steel bolt

The steel bolt of the structural anchor is made of stainless steel with material designation 1.4408 according to EN 10283 with a glass bead blasted finish. The bolt has a thread diameter M16. Details regarding nominal dimensions and the technical drawing of the bolt are given in Annex III.

3.4.3.2 Stainless steel anchor point

The steel anchor point of the structural anchor is especially designed for its application and is made of stainless steel with material designation 1.4408 according to EN 10283 with a glass bead blasted finish. The technical drawing of the anchor point is given in Annex III.

3.4.3.3 Stainless steel upper plate

The stainless steel upper plate is fabricated from steel grade 1.4432 according to EN 10088-2 with a glass bead blasted finish. Details regarding shape and dimensions of the plate have been specified in Annex III.

3.4.3.4 Stainless steel washer

The stainless steel washer is a flat washer with a steel grade A4 in accordance with EN ISO 3506-1 of type M16 with dimensions given in Annex III.

3.4.3.5 Stainless steel lower plate

The stainless steel lower plate is fabricated from steel grade 1.4301 according to EN 10088-2 with a glass bead blasted finish. Details regarding shape and dimensions of the plate may be found in Annex III.

3.4.3.6 Stainless steel spring washer

The stainless steel spring washer is designated an A2 steel grade spring washer according to EN ISO 3506-1. Nominal dimensions may be found in the technical drawing of the spring washer (see Annex III).

3.4.3.7 Stainless steel lock nut

The stainless steel lock nut is in accordance with EN ISO 7042, with a thread diameter M16 and a steel grade A2 according to EN ISO 3506-1. Nominal dimensions may be found in the technical drawing of the spring washer (see Annex III).

4 Assessment and verification of constancy of performance (AVCP) system applied, with reference to its legal base

In accordance with Regulation (EU) N° 305/2011, Directive 89/106/EEC is repealed, but references to the repealed Directive shall be construed as references to the Regulation.

For the products covered by this ETA, the applicable European legal act has been specified in the Commission Delegated Decision (EU) 2018/771 of 25 January 2018 on the applicable system to assess and verify constancy of performance of anchor devices used for construction works and intended to prevent persons from falling from a height or to arrest falls from a height pursuant to Regulation (EU) No 305/2011 of the European Parliament and of the Council⁷.

The system of assessment and verification of constancy of performance that applies is system 1+.

Products and intended use	Essential characteristics	Applicable system ^a
Anchor devices used for construction works and intended to prevent persons from falling from a height or to arrest falls from a height	For all essential characteristics	1+
^a See Annex V to Regulation (EU) N° 305/2011		

⁷ OJ L129, 25.05.2018, p. 82

5 Technical details necessary for the implementation of the AVCP system, as foreseen in EAD 330340-00-0606

5.1 Tasks for the Manufacturer - Factory production control (FPC)

The manufacturer shall install, document and maintain a FPC system that ensures the products placed on the market are conforming to the requirements of this ETA. The FPC system shall consist of procedures, regular inspections and controls in order to assure that the product characteristics are conforming to the initially determined product type.

All components of the product as well as the final product shall be regularly controlled as laid down in the control plan. The results of inspections and tests in the framework of the FPC system, as well as the eventual required actions to be taken, shall be documented. The product testing and evaluation plan shall be conform to the plan given in Annex I.

5.2 Tasks for the notified body

The cornerstones of the actions to be undertaken by the notified body in the procedure of assessment and verification of constancy of performance for factory made structural anchor for attaching personal fall protection equipment, designed to be permanently and fully bonded to a multi-layered roof waterproofing system are laid down in EAD 330340-00-0606, clause 3.3, and Annex II.

6 References

EN 363:2008	Personal fall protection equipment – Personal fall protection systems
EN 795:2012	Personal fall protection equipment – Anchor devices
EN 10088-2	Stainless steels - Part 2: Technical delivery conditions for sheet/plate and strip of corrosion resisting steels for general purposes
EN 10283	Corrosion resistant steel castings
EN 12311-1	Flexible sheets for waterproofing. Determination of tensile properties. Bitumen sheets for roof waterproofing
EN 12317-1	Flexible sheets for waterproofing. Bitumen sheets for roof waterproofing. Determination of shear resistance of joints
EN 13707:2013	Flexible sheets for waterproofing – Reinforced bitumen sheets for roof waterproofing – Definitions and characteristics
EN 15976	Flexible sheets for waterproofing. Determination of emissivity
EN ISO 3506-1	Mechanical properties of corrosion-resistant stainless steel fasteners - Part 1: Bolts, screws and studs
EN ISO 7042	Prevailing torque type all-metal hexagon high nuts - Property classes 5, 8, 10 and 12
EOTA TR 036: January 2013	A factory made structural anchor for attaching personal fall protection equipment, designed to be permanently fully bonded to a multi-layered modified bitumen roof waterproofing system provided with polyester reinforcement to a maximum roof slope of 15°, without perforating the roof waterproofing system

NOTE: The editions of reference documents given above are those, which have been adopted by the UBAtc for its specific use when establishing this ETA. When new editions become available, these supersede the editions mentioned only when confirmed by the UBAtc.

UBAtc asbl is a non-profit organization according to Belgian law. It is a Technical Assessment Body notified by the Belgian notifying authority, the Federal Public Services Economy, SMEs, Self-Employed and Energy, on 17 July 2013 in the framework of Regulation (EU) No 305/2011 of the European Parliament and of the Council of 9 March 2011 laying down harmonised conditions for the marketing of construction products and repealing Council Directive 89/106/EEC and is member of the European Organisation for Technical Assessment, EOTA (www.eota.eu).

This European Technical Assessment has been issued by UBAtc asbl, in Sint-Stevens-Woluwe, on the basis of the technical work carried out by the Assessment Operator, BCCA.

On behalf of UBAtc asbl,

Peter Wouters,
director

On behalf of the Assessment Operator, BCCA,
responsible for the technical content of the
ETA,

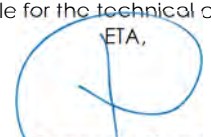
Benny De Blaere,
director general

The most recent version of this European Technical Assessment may be consulted on the UBAtc website (www.ubatc.be).

Annex I: Factory production control - testing plan

Table A.I.1. Factory production control (FPC)
[including testing of samples taken at the factory in accordance with a prescribed test plan]

No	<i>Subject/type of control (product, raw/constituent material, component - indicating characteristic concerned)</i>	<i>Test or control method</i>	<i>Criteria, if any</i>	<i>Minimum frequency of control</i>
Incoming materials/products per delivered batch				
1	Flexible reinforced bituminous membrane	3.8.2		each delivered batch
2	Anchor point, bolt, plates, spring washers and lock nut of stainless steel	3.8.3		each delivered batch
Testing of the structural anchor				
3	Control of the build-up of the structural anchor	3.8.1		Each week

Annex II: Factory production control - Testing plan

Table A.II.1. Sampling scheme for external testing

No	<i>Subject/type of control</i>	<i>Test method</i>	<i>Criteria, if any</i>	<i>number of samples/tests</i>	<i>Frequency of sampling</i>										
1	Strength of the assembly of steel components of the structural anchor	EAD 330340-00-0606, clause 2.2.3	in agreement with the results given in this ETA	1 assembly	1/year										
2	Tensile properties of the upper sheet of the structural anchor (force in N/50mm; strain in %)	EN 12311-1	<table border="1" style="border-collapse: collapse; width: 100%;"> <tr> <td rowspan="2" style="text-align: center; vertical-align: middle;">force:</td> <td style="text-align: center;">long.:</td> <td style="text-align: center;">900 (± 20%)</td> </tr> <tr> <td style="text-align: center;">trans.:</td> <td style="text-align: center;">750 (± 20%)</td> </tr> <tr> <td rowspan="2" style="text-align: center; vertical-align: middle;">strain:</td> <td style="text-align: center;">long.:</td> <td style="text-align: center;">45 (± 15)</td> </tr> <tr> <td style="text-align: center;">trans.:</td> <td style="text-align: center;">55 (± 15)</td> </tr> </table>	force:	long.:	900 (± 20%)	trans.:	750 (± 20%)	strain:	long.:	45 (± 15)	trans.:	55 (± 15)	2 x 5 specimen in each direction	1/year
force:	long.:	900 (± 20%)													
	trans.:	750 (± 20%)													
strain:	long.:	45 (± 15)													
	trans.:	55 (± 15)													
3	Flow resistance at elevated temperature of the lower sheet of the structural anchor (°C)	EN 1110	> 150	1	1/year										
4	Strength of the structural anchor on a multi-layered bituminous roof waterproofing system to be used in a fall arrest system														
	a) small scale testing before and after thermal ageing	EAD 330340-00-0606; clause 2.2.4.1 (*)	$\Delta s_2 < 20\%$	5 specimen	altering test a) and b) with a frequency of once per 3 years										
	b) small scale testing at low temperatures	EAD 330340-00-0606; clause 2.2.4.2	the rigid mass shall be arrested and held clearly from the ground	3 specimen											
(*) The test shall be conducted on specimens for which the ageing is applied on the combination of the structural anchor and the top layer of the multi-layered modified bituminous roof waterproofing membrane.															

Annex III: Technical details of the components of the structural anchor.

III.1 Stainless steel bolt

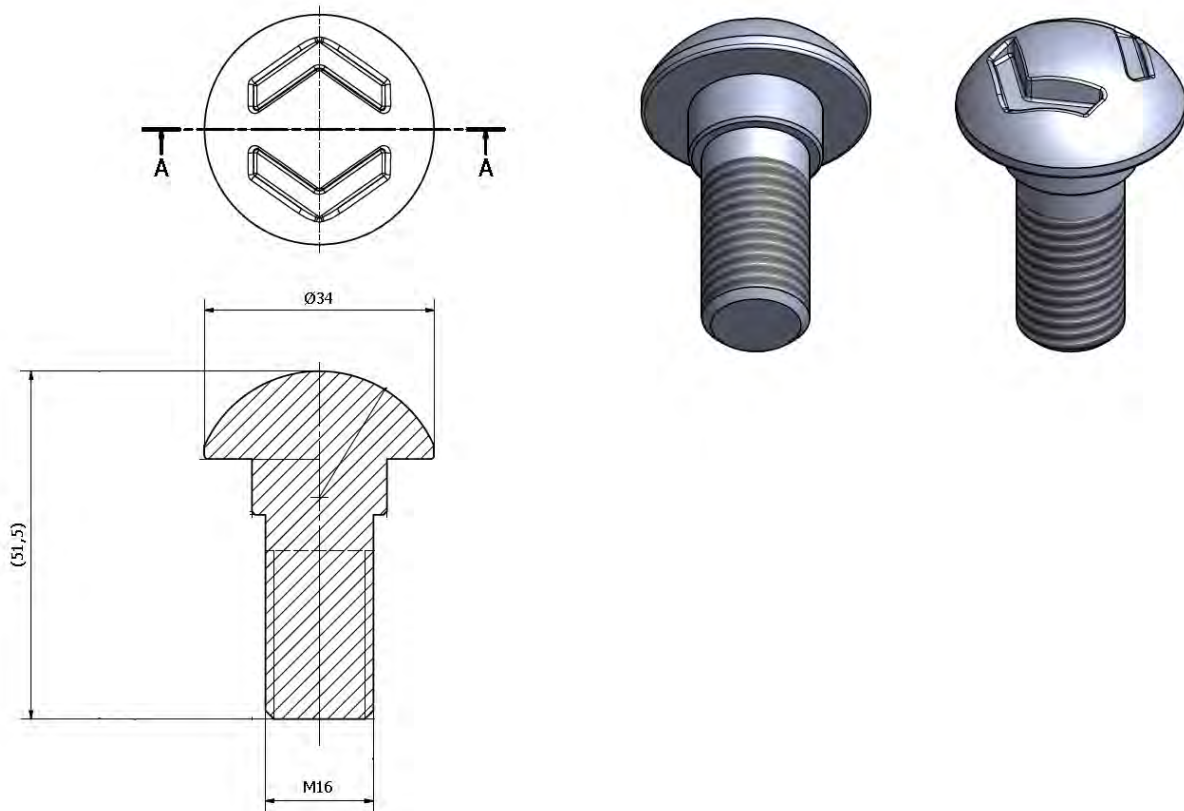

III.2 Stainless steel anchor point

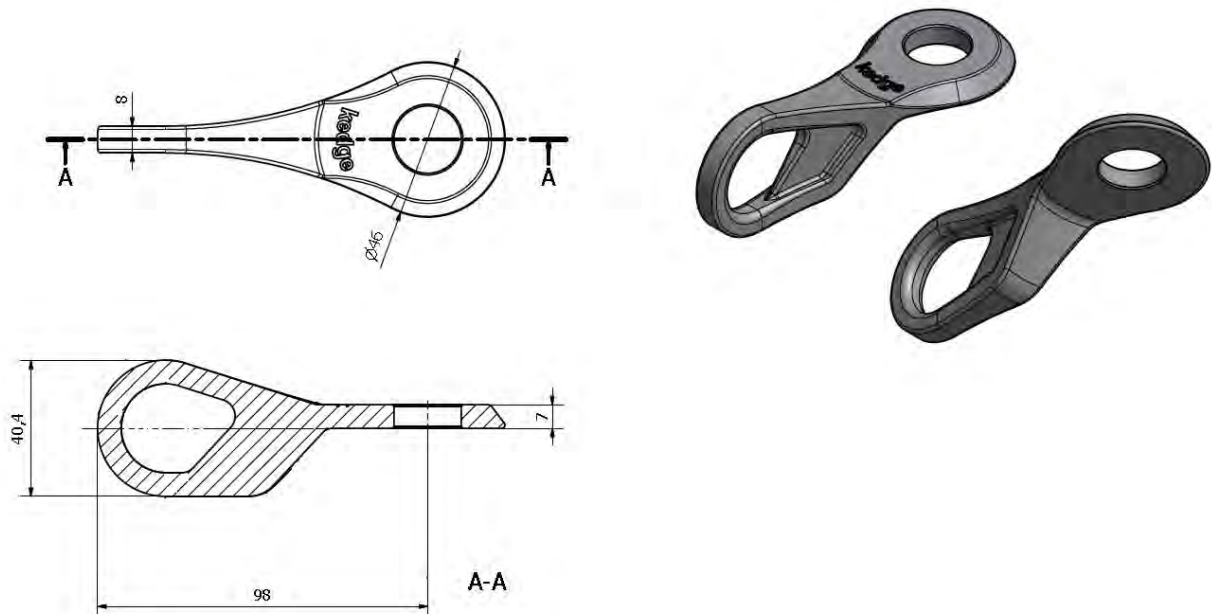

III.3 Stainless steel upper plate

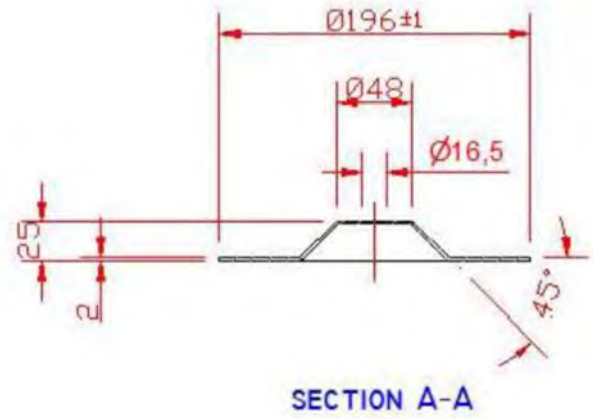
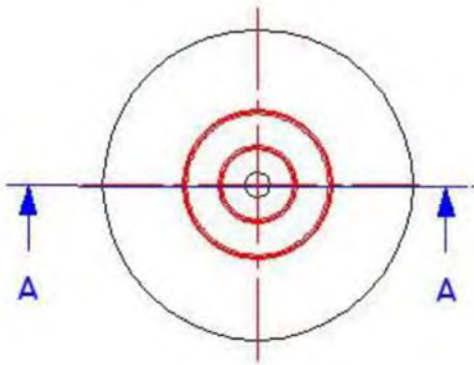

III.4 Stainless steel washer

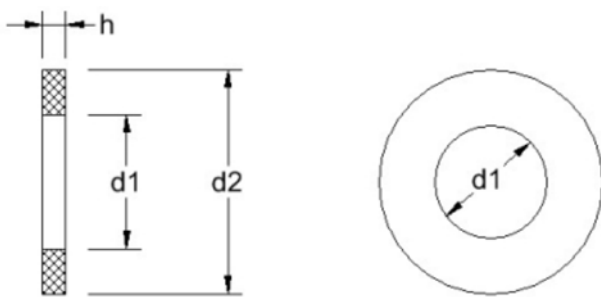

diameter	d1 (min)	d2 (max)	h
M16	17	40	3.0

III.5 Stainless steel lower plate

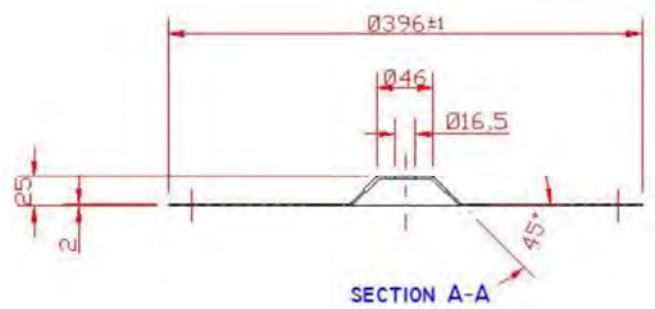
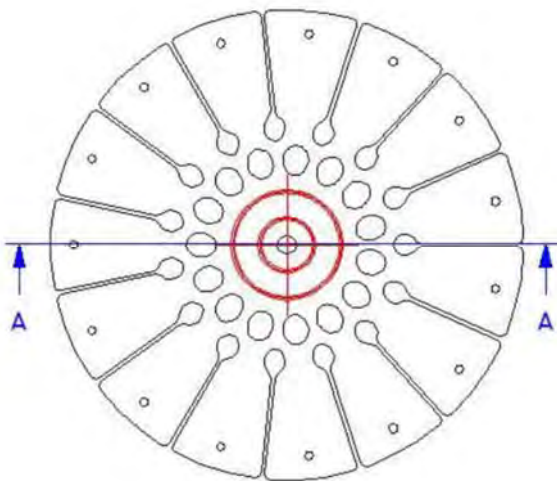

III.6 Stainless steel spring washer

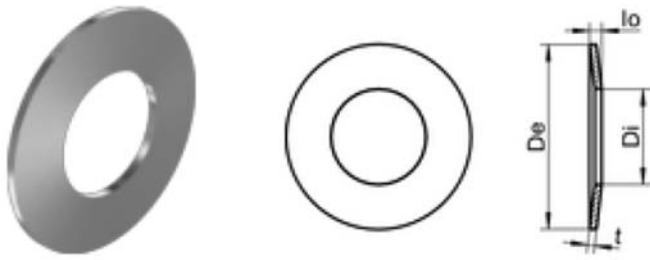

D_i	D_e	l_o	t
18.3	35.2	2.25	2.00

III.7 Stainless steel lock nut

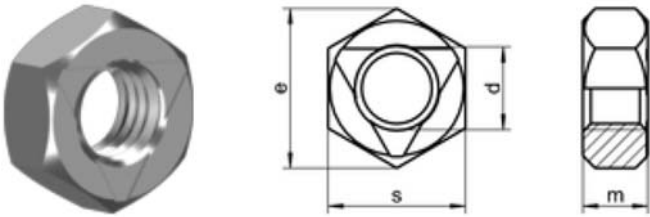

s	e	m
24	26.75	≥ 13.00