

# European Technical Assessment

**ETA 19/0316****Version 02**

Date of issue: 2026-01-05

**UBA<sub>t</sub>c Assessment Operator**

**Buildwise**  
Kleine Kloosterstraat 23  
1932 Sint-Stevens-Woluwe  
info@buildwise.be  
www.buildwise.be



**SECO Belgium**  
Registered office:  
Kolonienstraat 56 bus 10 1000  
Brussel  
Corporate office:  
Hermeslaan 9 1831 Diegem  
mail@seco.be -  
www.groupseco.be

**Technical Assessment Body issuing the European Technical Assessment: UBA<sub>t</sub>c.  
UBA<sub>t</sub>c has been designated according to Article 29 of Regulation (EU) No 305/2011  
and is member of EOTA (European Organisation for Technical Assessment)**

<b>Trade name of the construction product:</b>	WICLINE 70SG
<b>Product family to which the construction product belongs:</b>	9 - Structural sealant glazing kit for use in curtain walling
<b>Manufacturer:</b>	Hydro Building Systems Germany GmbH Einsteinstrasse 61 D-89077 Ulm Germany
<b>Manufacturing plant:</b>	Hydro Building Systems Germany GmbH Einsteinstrasse 61 D-89077 Ulm Germany
<b>Website:</b>	www.wicona.de
<b>This European Technical Assessment is issued in accordance with Regulation (EU) No 305/2011, on the basis of:</b>	EAD 090010-00-0404
<b>This version replaces:</b>	ETA 19/0316 (version 1), issued on 2019-11-26
<b>This European Technical Assessment contains:</b>	33 pages, including 1 Annex, which forms an integral part of the document



## European Organisation for Technical Assessment

## Legal bases and general conditions

1. This European Technical Assessment is issued by UBAtc (Union belge pour l'Agrément technique de la construction, i.e. Belgian Union for technical Approval in construction), in accordance with:
  - Regulation (EU) N° 305/2011<sup>1</sup> of the European Parliament and of the Council of 9 March 2011 laying down harmonised conditions for the marketing of construction products and repealing Council Directive 89/106/EEC
  - Commission Implementing Regulation (EU) N° 1062/2013<sup>2</sup> of 30 October 2013 on the format of the European Technical Assessment for construction products
  - EAD 090010-00-0404 "Bonded glazing kits and bonding sealants".
2. Under the provisions of Regulation (EU) No 305/2011, UBAtc is not authorized to check whether the provisions of this European Technical Assessment are met once the ETA has been issued.
3. The responsibility for the conformity of the performances of the products with this European Technical Assessment and the suitability of the products for the intended use remains with the holder of the European Technical Assessment.
4. Depending on the applicable Assessment and verification of constancy of performance (AVCP) system, (a) notified body(ies) may carry out third-party tasks in the process of assessment and verification of constancy of performance under this Regulation once the European Technical Assessment has been issued.
5. This European Technical Assessment allows the manufacturer of the construction product covered by this ETA to draw up a declaration of performance for the construction product.
6. CE marking should be affixed to all construction products for which the manufacturer has drawn up a declaration of performance.
7. This European Technical Assessment is not to be transferred to other manufacturers, agents of manufacturers, or manufacturing plants other than those indicated on page 1 of this European Technical Assessment.
8. The European Technical Assessment holder confirms to guarantee that the product(-s) to which this assessment relates, is/are produced and marketed in accordance with and comply with all applicable legal and regulatory provisions, including, without limitation, national and European legislation on the safety of products and services. The ETA-holder shall notify the UBAtc immediately in writing of any circumstance affecting the aforementioned guarantee. This assessment is issued under the condition that the aforementioned guarantee by the ETA-holder will be continuously observed.
9. According to Article 11(6) of Regulation (EU) N° 305/2011, when making a construction product available on the market, the manufacturer shall ensure that the product is accompanied by instructions and safety information in a language determined by the Member State concerned which can be easily understood by users. These instructions and safety information should fully correspond with the technical information about the product and its intended use, which the manufacturer has submitted to the responsible Technical Assessment Body for the issuing of the European Technical Assessment.
10. Pursuant to Article 11(3) of Regulation (EU) N° 305/2011, manufacturers shall adequately take into account changes in the product-type and in the applicable harmonised technical specifications. Therefore, when the contents of the issued European Technical Assessment do not any longer correspond to the product-type, the manufacturer should refrain from using this European Technical Assessment as the basis for their declaration of performance.
11. All rights of exploitation in any form and by any means of this European Technical Assessment is reserved for UBAtc and the ETA-holder, subject to the provisions of the applicable UBAtc regulations.
12. Reproduction of this European Technical Assessment including transmission by electronic means shall be in full. However, partial reproduction can be made with the written consent of UBAtc. In this case partial reproduction has to be designated as such. Texts and drawings of advertising brochures shall not contradict or misuse the European Technical Assessment.
13. Subject to the application introduced, this European Technical Assessment is issued in English and may be issued by the UBAtc in its official languages. The translations correspond fully to the English reference version circulated in EOTA.
14. This European Technical Assessment, ETA 19/0316 (identified as version 1), was first issued on 26 November 2019. Current version of the ETA, identified as ETA 19/0316 (version 2), issued 5 January 2026, introduces no technical changes other than changing the technical ground of the ETA from ETAG 002 to EAD 090010-00-0404.

---

<sup>1</sup> OJEU, L 88 of 2011/04/04

<sup>2</sup> OJEU, L 289 of 2013/10/31

## Technical provisions

### 1 Technical description of the product

#### 1.1 Definition of the product and intended use

##### 1.1.1 Definition of product

The WICLINE 70SG kit is a Bonded Glazing Kits (BGK) in which the glazing infills are bonded along the perimeter with a structural sealant to a metallic structural sealant support frame. This structural sealant glazing kit applies to opening parts for glass façades.

The WICLINE 70SG kit is of the type I or II as per EAD 090010-00-0404 table 1.1.1.1.

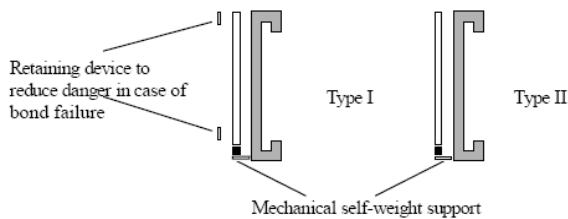

#### 1.2 Components of the kit

##### 1.2.1 Structural sealants

The following structural sealant types may be used:

- Silicone DOWSIL 993 or Sikasil SG-500 to seal the glazing on anodised aluminium or stainless-steel structural sealant support frame
- Silicone DOWSIL 993, DOWSIL 3362, DOWSIL 3362 HD, DOWSIL 3363, Sikasil SG-500, IG-25 or IG-25 HM to seal the outer structural edge seal of the insulating glass unit

Identification and detailed mechanical characteristics are given in the respective ETAs:

**Table 1 : applicable silicones**

Silicone	ETA
Applicable silicones to seal the glazing on anodised aluminium or stainless-steel structural sealant support frame	
DOWSIL 993	ETA 01/0005
SG-500	ETA 03/0038
Applicable silicones to seal the outer structural edge seal of the insulating glass unit	
DOWSIL 3362 or DOWSIL 3362 HD	ETA 03/0003
DOWSIL 3363	ETA 13/0359
IG-25	ETA 05/0068
IG-25 HM	ETA 05/0201

#### 1.2.2 Structural sealant retaining profile and structural sealant support frame

As stated in the definition of the product, opening parts are affixed to a structural sealant support frame.

All profiles and frames for structural sealant application are made of an aluminium alloy as described in table 2.

**Table 2 : aluminium alloy – characteristics**

Alloy Designation	Metallurgic state	Mechanical characteristics
EN 573-3	EN 515	
EN AW - 6060	T5/T66/T6	EN 755-2
EN AW - 6063	T6/T66	

**Table 3 : anodising characteristics of the structural sealant adhesion surface**

Characteristics	Method	EOTA Criteria	Nominal value
Thickness	EAD, clause D.2.2.1	Mean minimum thickness 15 µm	15 < th < 25
Sealing degree weight loss	EAD, clause D.2.2.2	EN ISO 3210: < 30 mg/dm <sup>2</sup>	< 30mg
Admittance at 1.000 Hz for a given thickness of 20µm	EAD, clause D.2.2.2	EN ISO 2931: < 20 µS	
Stain test	EAD, clause D.2.2.2	EN ISO 2143: < 2 on Qualanod scale	< 2

The anodising is performed by the companies listed in this ETA, clause 2.2.2.

The insert profile for bonding an insulating glass unit for the creation of opening parts is identified as profile 3091000.

Compatibility of the structural sealant and the materials which come in contact with it (silicone joint profiles 4010071, 4010072 and 4010153) have been positively evaluated.

#### 1.2.3 Suitable substrates for structural sealant bonding

The generic types of suitable substrates for adhesion to the structural sealant are:

- Float glass of soda lime silicate

The float glass shall conform to the following standard EN 572-1, -2, -4 and -5.

- Coated float glass

The suitable coated glass substrates are identified in the relevant ETA for structural glazing sealants; some other suitable coated glass products for the structural adhesion may be extrapolated following the rules mentioned in the EAD 090010-00-0404, clause D.3.1.1.4 (coated glass) without further testing for coatings classified as A, S and B according to EN 1096-1.

For other types of coated float glass, the coating shall be totally removed from the structural adhesion surface.

- Laminated safety glass

Laminated safety glass shall conform to the following standard: EN ISO 12543-2

- Thermally treated glass

Thermally treated glass shall conform to the following standards: EN 1863 or EN 12150

For special applications, the heat strengthened shall in addition conform to EN 14179

Heat soaked thermally toughened safety glass shall be produced by using float glass according to above section on float glass with provisions of the member states being complied with.

#### 1.2.4 Insulated glass unit

The kit of WICLINE 70SG is designed in such a way that the IGU outer edge seal is a structural edge seal.

The Insulated Glass Unit (IGU) is manufactured in accordance with the EN 1279 series of standards; insulated glass units made of two or three panes are covered in this ETA.

The structural outer edge seal is a silicone sealant conform to EAD 090010-00-0404 identified in Table 1

For each project the IGU's manufacturer shall deliver a technical dossier to his client as described in EAD 090010-00-0404, Table 3.2.2.

Dimensional tolerances on the IGU:  $\pm 2$  mm on the glass pane.

#### 1.2.5 Mechanical self-weight support

Mechanical self-weight supports shall be used, at a rate of two for every infill. They each support a setting block which supports all glass panes of the insulating glass units.

Examples of these self-weight supports are given in this ETA, annexes Fig. 2, Fig. 5, Fig. 8, Fig. 10, Fig. 11, Fig. 13 and Fig. 14. The self-weight supports shall be 100 mm or 150 mm wide and of an aluminium alloy according to this ETA, table 2.

The mechanical self-weight supports are identified as parts 4080060, 4080061, 4080062, 4080063, 4080064, 4080065 and 4080066.

#### 1.2.6 Retaining device

Retaining devices are means of retaining the glass to reduce danger in the event of structural sealant bond failure.

The necessity of these accessories is to be evaluated in function of the security specifications, of the situation of the building and of its working condition and also according to country demands.

The retaining device are identified as parts 4080058 and 4080059; see this ETA, annex Fig. 20).

#### 1.2.7 Joint sealing

After assembly, the joints between infill elements are to be sealed with one of the sealants below:

- DOWSIL 791 (Dow)
- DOWSIL 797 (Dow)
- Sikasil WS-605 S (Sika AG)

### 1.2.8 Accessories

#### 1.2.8.1 Aluminium profiles

- Fixed part profile for inserting sash profile in stick facade (profile 1030007, 1030008, 1030009, 1030010, 1030011 and 1030022)
- Opening sash profile for attachment of insert 3091000 (profile 3030033, 3030044, 3030058, 3030059, 3030065 and 3030067)

#### 1.2.8.2 Aluminium crimping parts

- Fixed part profile connector (part 4050192, 4050194)
- Sash corner connector (part 4050186, 4050190, 4050197, 4050198, 4050202, 4050196)

#### 1.2.8.3 Gaskets (fixed field)

- Mullion gasket (profile 190280, 190281, 190282)
- High thermal insulation mullion gasket (profile 190283, 190284, 190285)
- Transom gaskets (profile 190286, 190287, 190288)
- High thermal insulation transom gaskets (profile 190289, 190290, 190291)
- Glazing gasket (profile 190311)

#### 1.2.8.4 Gaskets (opening part)

- Outer sash gasket (profile 4010154, 4010155)
- First centre sash gasket (profile 4010161)
- Inner stop sash gasket (profile 4010045)
- Sealant glazing gasket (profile 4010071, 4010072, 4010153)

#### 1.2.8.5 Thermal break profile

- Support profile (profile 4030168, 4030169, 4030188, 4030281, 4030313, 4030317, 4030323)
- Transom/mullion thermal break (profile 196061, 196062, 196063, 196064, 4030267, 4030268)

#### 1.2.8.6 Iron work

- Turn/tilt:
  - 6940500, 6940501, 6940502, 6940503
- Tilt first:
  - 6940504, 6940505
  - 6940506, 6940507
- Turn:
  - 6940515, 6940516
- Tilt:
  - 6940514

#### 1.2.8.7 Setting blocks

The glazing dead load is transferred by setting blocks with suitable hardness and compatible with the sealants in this ETA, Table 1.

The setting blocks are identified as parts 4020567, 4020594 and 4020595.

#### 1.2.8.8 Cleaning products for the adhesive surface

The cleaning products used for cleaning of the adhesive surface, should be those recommended by the sealant suppliers. The processing instructions of the adhesive suppliers shall also be respected. This information may be found in the applicable ETA specified in this ETA, 0.

## 2 Specification of the intended use(s) in accordance with the applicable EAD

### 2.1 General

Bonded glazing kits (BGK) for use as infill for curtain walling in a vertical position. In general for BGK an inclination is only allowed towards the inside of the building, as tensile stress of the structural sealant resulting of the self-weight is not allowed; in this case the inclination shall however be limited to the vertical as not to induce movements of the sash in its unlocked position due to its self-weight.

The infill elements may only be used for installation heights that are admissible by regulations of the respective member states. The infill may also be used in overhead area. The inner pane of the insulating glass unit placed overhead shall be laminated safety glass as described in this ETA, clause 1.2.2. The façade structure is not part of the present ETA. The infill elements shall not be used for the stiffening of other components.

The restrictive provisions of the various member states with regard to the application shall be taken into consideration. Due to national requirements in some countries, retaining devices may need to be used.

The system is intended to be used in curtain walling for which requirements ER2 safety in case of fire, ER3 Hygiene, health and the environment, ER4 Safety and accessibility in use, ER5 Protection against noise and ER6 Energy economy and heat retention shall be fulfilled. The failure of the structural bond would cause risk to human life and/or considerable economic consequences.

The provisions made in this European Technical Assessment are based on the assumed working life of the BGK of 25 years. The assumed working life of a system cannot be taken as a guarantee given by the producer, but are to be used as a means for selecting the appropriate product in relation to the expected economically reasonable working life of the works.

### 2.2 Provisions related to manufacturing, packaging and storage

#### 2.2.1 Manufacturing

This European Technical Assessment is issued for the kit on the basis of agreed data / information deposited with the UBAtc, which identifies the product that has been assessed and judged. Changes to the product or production process, which could result in this deposited data / information being incorrect should be notified to the UBAtc before the changes are introduced. UBAtc decides whether such changes do or do not affect the ETA.

The infill elements may only be manufactured and sealed in plants that are authorised by Hydro Building Systems for producing such infill units. The personnel performing these duties shall be adequately trained by the adhesive manufacturers.

The surfaces to be sealed may only be prepared in conformity with the manufacturing directives (see this ETA, clause 1.2.8.8, Cleaning products for the adhesive surface).

#### 2.2.2 Bonding the glazing

The use of primer is assessed per batch of adaptor by adhesion test with the project structural sealant(s). The anodising of the structural adhesion surface profile (3091000) is performed by the following companies:

- BWG Altenheim AG, CH-9423 Altenheim
- Piesslinger, im Gstadt 1, A-4591 Molln
- Eloxal Gerhard Gotta, Max-Planck-Str.12, D-63322 Rödermark
- HD Wahl GmbH, Dieselstrasse 6-8, D-89343 Jettingen Scheppach, Germany

The anodised aluminium profile has been assessed as suitable adhesion substrate for the bonding. The following combinations of anodizing/sealant have been assessed fit for use:

Anodizing	Sealant	Cleaner	Primer
Eloxal Gerhard Gotta			Not necessary
BWG Altenrhein AG	DOWSIL 993	Cleaner R40	Primer DOWSIL 1200
Piesslinger GmbH			Not necessary
HD Wahl GmbH			Primer DOWSIL 1200
Eloxal Gerhard Gotta			
BWG Altenrhein AG	SG-500	Cleaner G & M	Not necessary
Piesslinger GmbH			
HD Wahl GmbH		Cleaner P, or Cleaner G & M	

After adhesion tests by the sealant supplier, the sealant suppliers can always demand the use of primers. In such cases primers shall be used even if no primers are indicated in the tables above.

The structural bond in the space between the glass and the aluminium profile shall be completely filled all around. Bubbles, voids or inclusions in the structural sealant are not permissible.

### 2.3 Provisions related to the design and use of the product

#### 2.3.1 Design rules

##### 2.3.1.1 Structural seals design

The bonding seal shall be calculated according to the manufacturer specifications respecting the following: the minimum dimensions of the bonding seal are  $e \geq 6$  mm,  $h_c \geq 6$  mm (for the definition of e, h and r: see EN 13022-2).

##### 2.3.1.2 Design rules for the frames

The frames are designed following the specifications of EN 13830 and national provisions, the windows according to EN 14351-1 and national provisions.

### 2.3.1.3 Maximum dimensions

The opening parts shall not exceed (width x height):

- For turn/tilt window: 1,60 m x 2,25 m or 1,00 m x 2,50 m
- For tilt-first window: 1,60 m x 2,25 m or 1,00 m x 2,50 m
- For turn window: 1,60 m x 2,25 m or 1,00 m x 2,50 m
- For tilt window, portrait: 1,60 m x 2,25 m or 1,00 m x 2,50 m
- For tilt window, landscape: 2,25 m x 1,60 m or 2,50 m x 1,00 m

### 2.3.1.4 Transfer of the dead load of the infill panel to façade structure (for fixed part and opening light)

The mechanical self-weight support devices are given in this ETA, clause 1.2.5. The load bearing capacity of the following parts has been verified:

- 4080060: 1500 N (with a safety factor of 1,25)
- 4080061: 1500 N (with a safety factor of 1,25)
- 4080062: 1400 N (with a safety factor of 1,25)
- 4080064: 1400 N (with a safety factor of 1,25); at this load the deflection between the centres of gravity of the glass panes of the IGU is superior to 0,5 mm. To limit the deflection to 0,5 mm the load shall be limited to 1000 N
- 4080065: 1000 N (with a safety factor of 1,25); at this load the deflection between the centres of gravity of the glass panes of the IGU is superior to 0,5 mm. To limit the deflection to 0,5 mm the load shall be limited to 850 N
- 4080066: 800 N (with a safety factor of 1,25); at this load the deflection between the centres of gravity of the glass panes of the IGU is superior to 0,5 mm. To limit the deflection to 0,5 mm the load shall be limited to 400 N

### 2.3.1.5 Retaining devices and glass holders

The retaining devices are given in this ETA, clause 1.2.6. The load bearing capacity of the following parts has been verified:

- 4080058: 150 N (with a safety factor greater than 2,0)
- 4080059: 150 N (with a safety factor greater than 2,0)

### 2.3.1.6 Iron work

- 6940500, 6940501: Turn/Tilt basic hardware concealed, Retainer arm size 1, max. sash weight: 160 kg
- 6940502, 6940503: Turn/Tilt basic hardware concealed, Retainer arm size 2, max. sash weight: 160 kg
- 6940504, 6940505: Tilt-First basic hardware concealed, Retainer arm size 1, max. sash weight: 160 kg
- 6940506, 6940507: Tilt-First basic hardware concealed, Retainer arm size 2, max. sash weight: 160 kg
- 6940515, 6940516: Turn basic hardware, concealed, max. sash weight: 160 kg
- 6940514: Tilt basic hardware concealed, max. sash weight: 130 kg

### 2.3.2 Installation – Specification on the façade structure

The elements shall be bonded with respect to the provisions in the workshop manual of the company Hydro Building Systems Germany GmbH, in a way that no restraints in the elements may occur. The installation shall be performed by trained personnel only, who have been trained for these works by the company Hydro Building Systems Germany GmbH.

### 2.3.3 Maintenance and repair

#### 2.3.3.1 Repair

All damages noticed on the structural sealant system shall be repaired as follows:

- Dismantling of the structural sealant unit
- Replacement by a new unit or
- Repair of the damaged unit in the workshop

#### 2.3.3.2 Maintenance

The cleaning of the façade shall be carried out only with water adding a maximum of 1% of surfactants without other chemical additions or other cleaning methods (e.g. steam pressure rays).

Other products may be used provided they are assessed for conformity to EAD 090010-00-0404 Clause 2.2.15.1.6 (façade cleaning agents).

### 2.3.4 Dangerous substances

Relating to the "Dangerous substances" the manufacturer of the elements has made a declaration of compliance with Council Directive 76/769/EC of July 1976.

In addition to the specific clauses relating to dangerous substances contained in this European Technical Assessment, there may be other requirements applicable to the products falling within its scope (e.g. transposed European legislation and national laws, regulations and administrative provisions). In order to meet the provisions of the Regulation (EU) N° 305/2011, these requirements need also to be complied with, when and where they apply.

### 3 Performance of the product and references to the methods used for its assessment

#### 3.1 General

The assessment of the structural sealant for the intended use in relation to the requirement for safety in case of fire, hygiene, health and environmental safety in use, protection against noise, energy economy and heat retention, in the sense of Essential Requirements 2 to 6 has been made in accordance with EAD 090010-00-0404.

Except the characteristics of the bonding itself, most of the performances cannot be assessed as they are applicable not only to the glazing frame alone. However, the performances of the assembled façade shall be assessed according to EN 13830.

#### 3.2 Safety in case of fire (ER2)

- Reaction to fire: No performance assessed
- Resistance to fire: No performance assessed
- Façade fire performance: No performance assessed
- External fire performance of roofs: No performance assessed
- Partial collapse in case of fire: No performance assessed

#### 3.3 Hygiene, health and the environment (ER3)

##### 3.3.1 Air permeability

Air permeability of the facade element is of class AE when classified according to EN 12152

Air permeability of the window element is of class A4 when classified according to EN 12207

##### 3.3.2 Water tightness

Water tightness of the facade element is of class RE1200 when classified according to EN 12154

Water tightness of the window element is of class E750 when classified according to EN 12208

No dampness due to water penetration or due to condensation appears at any position not designed to be subjected to the prolonged effects of liquid water.

#### 3.4 Safety and accessibility in use (ER4)

##### 3.4.1 General

Stability of the elements and their anchorage on the structure is demonstrated. The following aspects have been particularly considered:

- Self-weight
- Wind
- Temperature
- Climatic conditions.

#### 3.4.2 Verification of structural bond

It shall be verified that the structural bond under the actions given in this ETA, clause 3.4, is not exposed to any stresses exceeding 0,14 N/mm<sup>2</sup> perpendicular to the adhesion surface. Compared to a continuous load, the internal forces and moments in the structural bond are to be multiplied by a factor  $\gamma_{\text{sys}} = 3.0$ . The shear deformation of the seam due to temperature differences of  $\Delta T = 35 \text{ K}$  shall be smaller than 23.4 %.

Design of the structural bond shall be carried out in accordance with the regulations of the Member States, in which the infill will be used.

#### 3.4.3 Verification of the insulating glass

The verification of the stability of the panels shall be made under the actions mentioned in this ETA, clause 3.4, according to the rules of the responsible member state.

#### 3.4.4 Verification of support

The support 4080060 according to this ETA, Annex Fig. 13, is designed to bear the self-weight of the sash infill elements and has a permissible load of up to 1590 N (per support) with a safety factor of 1,25 or greater.

The support 4080061 according to this ETA, Annex Fig. 13, is designed to bear the self-weight of the sash infill elements and has a permissible load of up to 1646 N (per support) with a safety factor of 1,25 or greater.

The support 4080062 according to this ETA, Annex Fig. 13, is designed to bear the self-weight of the sash infill elements and has a permissible load of up to 2059 N (per support) with a safety factor of 1,25 or greater.

The support 4080064 according to this ETA, Annex Fig. 13, is designed to bear the self-weight of the sash infill elements and has a permissible load of up to 1590 N (per support) with a safety factor of 1,25 or greater.

The support 4080065 according to this ETA, Annex Fig. 13, is designed to bear the self-weight of the sash infill elements and has a permissible load of up to 1496 N (per support) with a safety factor of 1,25 or greater.

The support 4080066 according to this ETA, Annex Fig. 13, is designed to bear the self-weight of the sash infill elements and has a permissible load of up to 1590 N (per support) with a safety factor of 1,25 or greater.

#### 3.4.5 Deflection of the frames

The deflection of the framing profiles supporting the glass pane shall not exceed – in the area of the pane edge – 1/300 of the concerned edge length, additionally for insulating glass unit glass pane edges the deflection shall not exceed 12 mm. The deflection of the glass panel in the centre of the pane in case of service load shall not exceed 1/100 of the smallest support edge of the glass pane.

#### 3.4.6 Verification of retaining device (fixing)

The retaining devices 4080058 and 4080059 shall be screwed onto the infill sash profile at a distance from the infill corner of not more than 85 mm.

The admissible load bearing capacity of the retaining devices 4080058 and 4080059 (see this ETA, annexes Fig. 20) is assessed and equals 150 N with a safety factor greater than 2.

### 3.4.7 Sill heights

Sill heights may be adapted to any required height.

The regulations in the Member States, in which the structural sealant glazing kit is used, shall be observed.

### 3.4.8 Impact resistance

In the context of issuing this ETA, the verification of impact of the structure was performed and classified to I5/E5 according to EN 14019.

In the context of issuing this ETA, the verification of impact of the opening parts was performed and classified to class 1 (in the opening direction) and class 2 (in the closing direction) according to EN 13049.

The regulations concerning barrier against falling through in the Member States, in which the structural sealant glazing kit is used, shall be observed.

### 3.4.9 Wind resistance

The design load (Service Limit State characteristic wind load for serviceability, EN 13116) is 2000 N/m<sup>2</sup> (positive and negative loads) for the facade construction. The safety wind load (Ultimate Limit State, EN 13116) is 3000 N/m<sup>2</sup> (positive and negative loads) for the facade construction.

Opening parts are classified as C4 according to EN 12210.

The regulations in the Member States, in which the structural sealant glazing kit is used, shall be observed.

#### 3.4.10 Behaviour in fire

No performance assessed. The regulations in the Member States, in which the structural sealant glazing kit is used, shall be observed.

#### 3.4.11 Flexural tensile strength

No characteristic value of the flexural tensile strength of the multi-pane insulating glass has been assessed. The regulations in the Member States, in which the structural sealant glazing kit is used, shall be observed.

### 3.5 Protection against noise (ER5)

In the context of issuing this ETA, the performance capacities of the protection against noise has not been assessed. For the structure verification regarding the protection against noise, the regulations of the Member States apply.

### 3.6 Energy economy and heat retention (ER6)

The U<sub>f</sub> values are calculated according to EN ISO 10077-2.

**Table 4 : U<sub>f</sub> values of typical sections**

			U <sub>f</sub> W/(m <sup>2</sup> × K)
Without opening parts (transom/mullion profile: 3030046, glazing bead: 3030034, IGU thickness: 36 mm)			
Transom/mullion thermal break:	Transom/mullion inner glazing gasket		
196062	190281		1,7
196062	190284		1,5
196154	190284		1,1
With opening parts (transom/mullion profile: 3030046, sash profile: 3030033, IGU thickness: 36 mm)			
Transom / mullion thermal break:	Sash gasket	Transom / mullion inner glazing gasket	
196062	4010154	190281	2,1
196062	4010172	190281	2,2
196062	4010154	190284	2,0
196062	4010172	190284	2,1
196154	4010154	190284	1,8
196154	4010172	190284	1,9
With opening parts (transom/mullion profile: 3030046, sash profile: 3030044, IGU thickness: 58 mm)			
Transom / mullion thermal break:	Sash gasket	Transom / mullion inner glazing gasket	
4030268	4010154	190282	1,7

For the structure verification regarding energy economy and heat retention, the regulations of the Members States apply.

## 4 Assessment and verification of constancy of performance (AVCP) system applied, with reference to its legal base

In accordance with Regulation (EU) N° 305/2011, Article 65, Directive 89/106/EEC is repealed, but references to the repealed Directive shall be construed as references to the Regulation.

The systems of assessment and verification of constancy of performance specified by the European Commission detailed in EC Decision 96/582/EC<sup>3</sup> are as follows:

- System 1 (without audit testing of samples) for Bonded Glazing Kits Type II and IV;
- System 2+ (first possibility, including certification of the factory production control (FPC) by a notified body on the basis of its continuous surveillance, assessment and assessment) for Bonded Glazing Kits Type I and III

The system(s) of assessment and verification of constancy of performance are shown in the following Table.

**Table 5 : System(s) of assessment and verification of constancy of performance**

Product(s)	Intended use(s)	Level(s) or class(es)	Assessment and verification of constancy of performance system(s)*
Structural sealant glazing kits type II and IV	External walls and roofs	none	1
Structural sealant glazing kits type I and III		none	2+

\* See Annex V to Regulation (EU) N° 305/2011

In practice, the operation of systems 1 and 2+ will be very similar for Bonded Glazing Kits, for the following reasons:

- the results of assessment testing shall be used by notified bodies (cf. Regulation (EU), Annex V, clause 1.6)
- the nature of the product is such that testing of samples at the factory by the manufacturer will be required under the FPC arrangements.

## 5 Technical details necessary for the implementation of the AVCP system

### 5.1 Tasks for the ETA-holder

#### 5.1.1 Factory production control (FPC)

##### 5.1.1.1 General

The manufacturer shall establish, document and maintain an FPC system to ensure that the products placed on the market conform to the assessed performance characteristics. The FPC system shall consist of procedures, regular inspections and tests and/or assessments and the use of the results to control raw and other incoming materials or components, equipment, the production process and the product.

An FPC system conforming with the requirements of EN ISO 9001, and made specific to the requirements of this ETA, is considered to satisfy the above requirements.

The results of inspections, tests or assessments requiring action shall be recorded, as shall any action taken. The action to be taken when control values or criteria are not met shall be recorded.

The ETA holder of the kit is responsible for setting up appropriate rules and instructions for façadiers and the bonding workshops (quality manual for kit assembling and bonding). The different actors are bound via contractual links with the ETA holder to respect the kit holder's rules and instructions, which are an integral part of the FPC system.

##### 5.1.1.2 Equipment

All weighing, measuring and testing equipment shall be calibrated and regularly inspected according to documented procedures, frequencies and criteria.

##### 5.1.1.3 Raw materials and components

The specifications of all incoming raw materials and components shall be documented, as shall the inspection scheme for ensuring their conformity.

##### 5.1.1.4 Non-conforming products

In the event of any non-conformity of any product, that product shall be placed into quarantine and action taken to rectify the cause of the non-conformity. Products may not subsequently be dispatched until the problem has been resolved.

##### 5.1.1.5 Tests and frequencies

All the elements, requirements and provisions adopted by the manufacturer are documented in a systematic manner in the form of written policies and procedures. This production control system ensures that the product is in conformity with the European Technical Assessment (ETA).

This relates only to taking samples representative of the final product. In the context of Bonded Glazing Kits the testing of "H" pieces, peel tests as part of FPC provides the necessary evidence.

<sup>3</sup> Commission decision of 24/06/96, published in the EC Official Journal L254 of 08/10/96

## 5.2 Tasks for the Technical Assessment Body

### 5.2.1 Initial Type Testing

Assessment tests on the sealant have been conducted under the responsibility by the assessment body (UBAtc) in accordance with EAD 090010-00-0404 table 2.1.2, as part of the ETA issuing procedure. The results of assessment testing shall be used by notified bodies (cf. Regulation (EU), Annex V, clause 1.6).

### 5.2.2 Assessment of the factory production control - Initial inspection and continuous surveillance

Assessment of the FPC is the responsibility of a notified body.

An assessment shall be carried out on the required manufacturing steps of each manufacturing plant to demonstrate that the factory production control is in conformity with the ETA and any subsidiary information. This assessment is based on an initial inspection of the different manufacturing actors' plants (kit designer; façadier(-s) and bonding workshops).

Subsequently continuous surveillance of factory production control is necessary to ensure continuing conformity with the ETA. This continuous surveillance shall be in conformity with to EAD 090010-00-0404, chapter 3.3 at each identified manufacturing plant.

It is recommended that surveillance inspections should be conducted at least twice a year at each identified manufacturing plant.

## 6 Bibliography

EAD 090010-00-0404 Bonded glazing kits and bonding sealants

EN 515 Aluminium and aluminium alloys. Wrought products. Temper designations

EN 572-1, -2, -4 and -5 Glass in building - Basic soda lime silicate glass products

EN 573-3 Aluminium and aluminium alloys - Chemical composition and form of wrought products - Part 3: Chemical composition and form of products

EN 755-2 Aluminium and aluminium alloys - Extruded rod/bar, tube and profiles - Part 2: Mechanical properties

EN 1096-1 Glass in building - Coated glass - Part 1: Definitions and classification

EN 1279-1, -2, -3, -4, -5 and -6 Glass in building - Insulating glass units

EN 1863-1 and -2 Glass in building - Heat strengthened soda lime silicate glass

EN 12207 Windows and doors - Air permeability - Classification

EN 12208 Windows and doors - Watertightness - Classification

EN 12150-1 Glass in building - Thermally toughened soda lime silicate safety glass - Definition and description

EN 12150-2 Glass in building - Thermally toughened soda lime silicate safety glass - Evaluation of conformity/Product standard

EN 12152 Curtain walling - Air permeability - Performance requirements and classification

EN 12154 Curtain walling - Watertightness - Performance requirements and classification

EN 12210 Windows and doors - Resistance to wind load - Classification

EN 12844 Zinc and zinc alloys - Castings - Specifications

EN 13049 Windows - Soft and heavy body impact - Test method, safety requirements and classification

EN 13116 Curtain walling - Resistance to wind load - Performance requirements

EN 13830 Curtain walling - Product standard

EN 14019 Curtain Walling - Impact resistance - Performance requirements

EN 14179-1 and -2 Glass in building - Heat soaked thermally toughened soda lime silicate safety glass

EN 14351-1 Windows and doors - Product standard, performance characteristics - Part 1: Windows and external pedestrian doorsets without resistance to fire and/or smoke leakage characteristics

EN ISO 2143 Anodizing of aluminium and its alloys - Estimation of loss of absorptive power of anodic oxidation coatings after sealing - Dye-spot test with prior acid treatment

EN ISO 2931 Anodizing of aluminium and its alloys - Assessment of quality of sealed anodic oxidation coatings by measurement of admittance (ISO 2931:2010)

EN ISO 3210 Anodizing of aluminium and its alloys - Assessment of quality of sealed anodic oxidation coatings by measurement of the loss of mass after immersion in phosphoric acid/chromic acid solution

EN ISO 7050 Cross-recessed countersunk (flat) head tapping screws

EN ISO 9001 Quality management systems - Requirements

EN ISO 10077-2 Thermal performance of windows, doors and shutters - Calculation of thermal transmittance - Numerical method for frames

EN ISO 12543-2 Glass in building - Laminated glass and laminated safety glass - Part 2: Laminated safety glass

UBAtc asbl is a non-profit organization according to Belgian law. It is a Technical Assessment Body notified by the Belgian notifying authority, the Federal Public Services Economy, SMEs, Self-Employed and Energy, on 17 July 2013 in the framework of Regulation (EU) No 305/2011 of the European Parliament and of the Council of 9 March 2011 laying down harmonised conditions for the marketing of construction products and repealing Council Directive 89/106/EEC and is member of the European Organisation for Technical Assessment, EOTA ([www.eota.eu](http://www.eota.eu)).

This European Technical Assessment has been issued by UBAtc asbl, in Sint-Stevens-Woluwe, on the basis of the technical work carried out by the Assessment Operators, Buildwise and SECO Belgium.

On behalf of UBAtc asbl,

On behalf of the Assessment Operator,  
Buildwise and SECO Belgium, responsible for the  
technical content of the ETA,



Bart De Pauw,  
General manager



Olivier Vanhooren,  
CEO Buildwise



Bernard Heiderscheidt,  
CEO SECO Belgium

The most recent version of this European Technical Assessment may be consulted on the UBAtc website ([www.butgb-ubatc.be](http://www.butgb-ubatc.be)).

# Annex 1

Fig. 1 Sash profile for glass thickness 28 – 44 mm with gasket 4010154 (mullion section, 28 mm IGU)

## WICLINE 70SG

Flügelprofil für Glasdicke 28 - 44 mm mit Dichtung 4010154  
 Sash profile for glass thickness 28 - 44 mm with gasket 4010154

Konstruktionsschnitt  
 Construction section

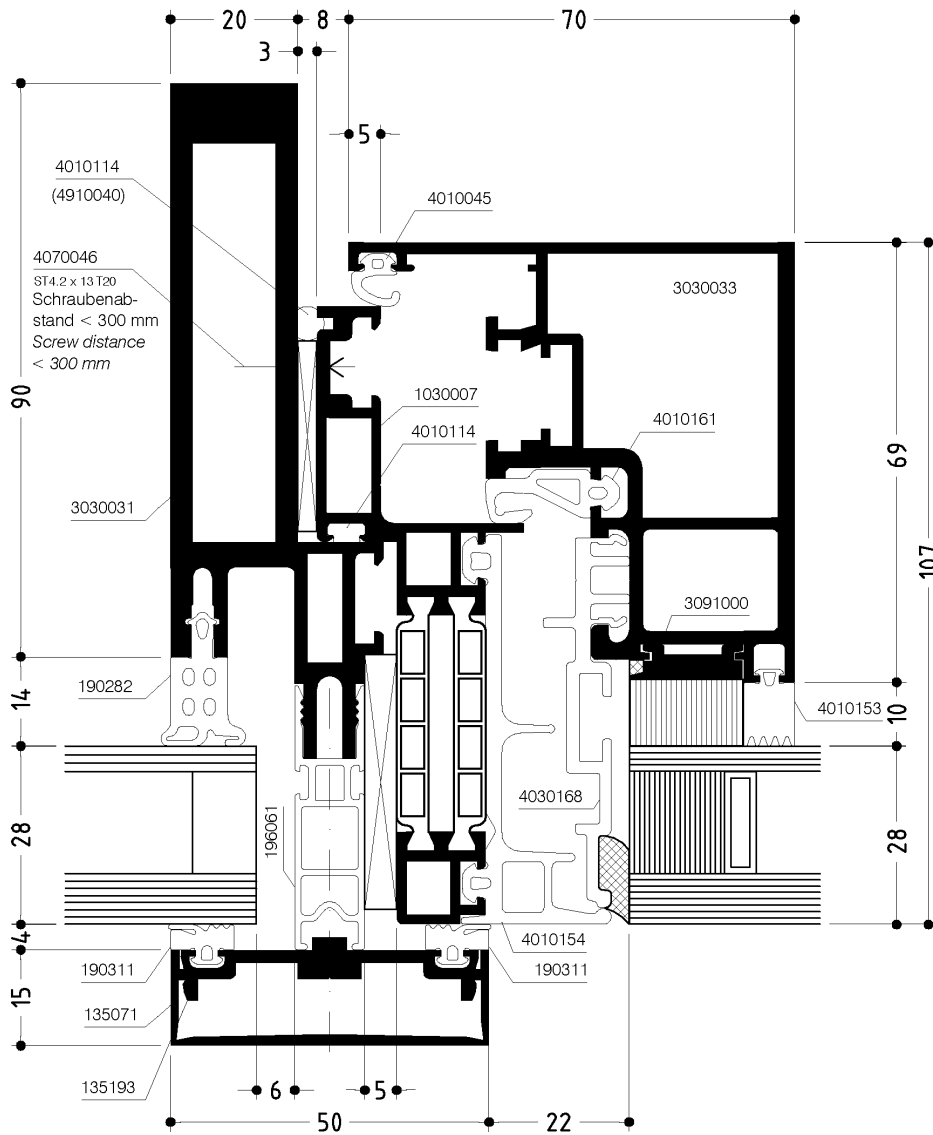
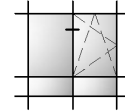

Fig. 2 Sash profile for glass thickness 28 – 44 mm with gasket 4010154 (lower transom section, 28 mm IGU)

# WICLINE 70SG

Flügelprofil für Glasdicke 28 - 44 mm mit Dichtung 4010154  
 Sash profile for glass thickness 28 - 44 mm with gasket 4010154

Konstruktionsschnitt  
 Construction section

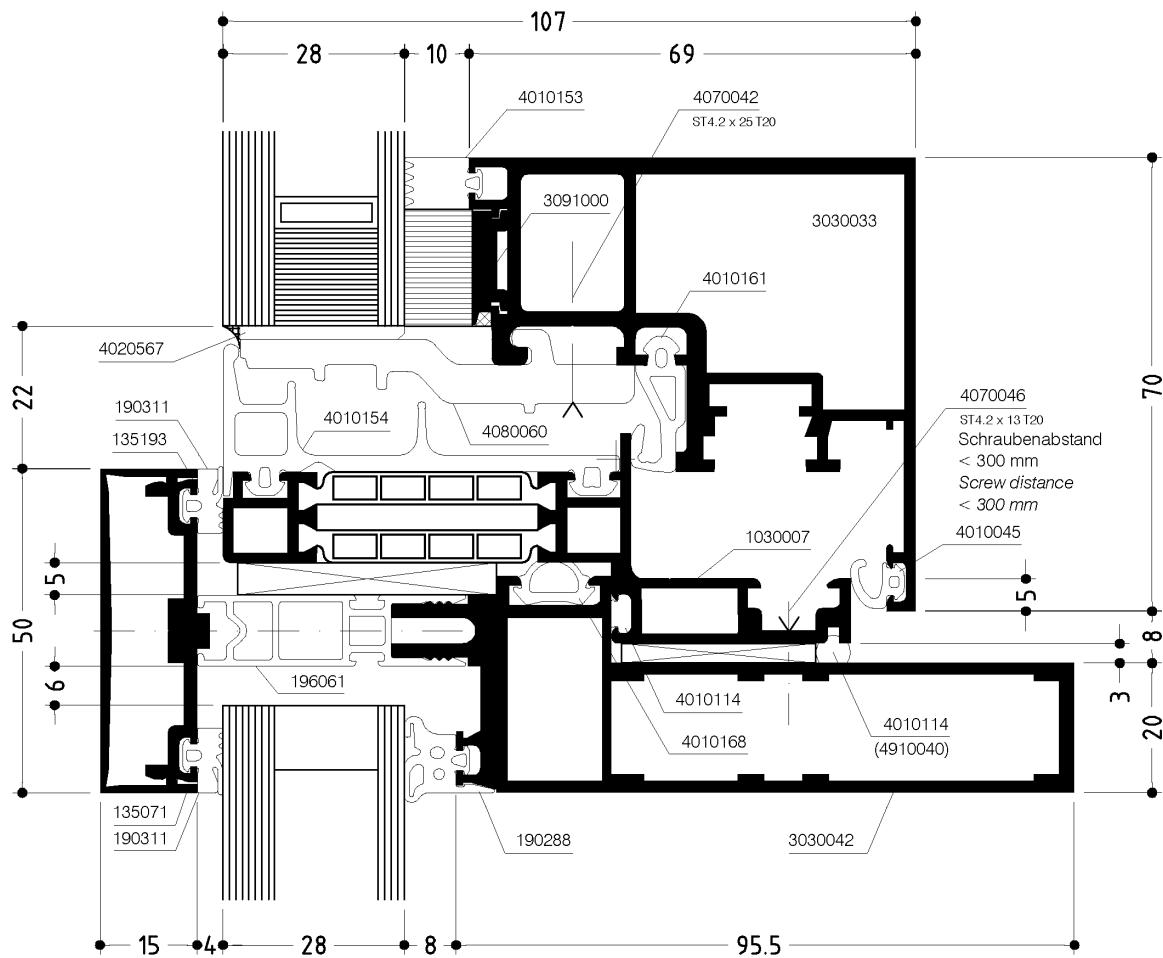
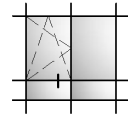



Fig. 4 Sash profile for glass thickness 40 – 62 mm with gasket 4010155 (mullion section, 46 mm IGU)

# WICLINE 70SG

Flügelprofil für Glasdicke 40 - 62 mm mit Dichtung 4010155  
 Sash profile for glass thickness 40 - 62 mm with gasket 4010155

Konstruktionsschnitt  
 Construction section

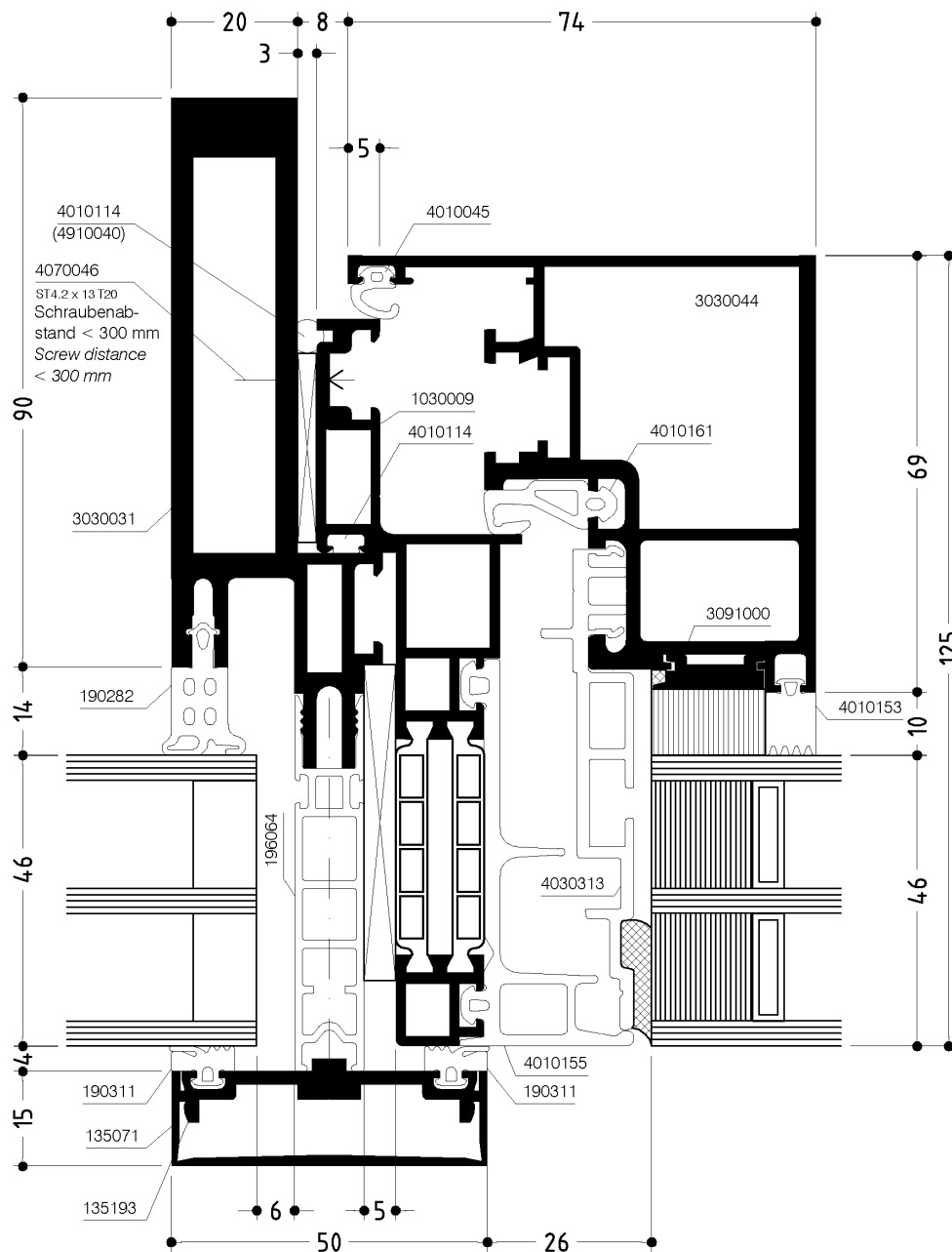
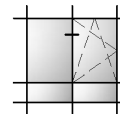

Fig. 5 Sash profile for glass thickness 40 – 62 mm with gasket 4010155 (lower transom section, 46 mm IGU)

# WICLINE 70SG

Flügelprofil für Glasdicke 40 - 62 mm mit Dichtung 4010155  
 Sash profile for glass thickness 40 - 62 mm with gasket 4010155

Konstruktionsschnitt  
 Construction section

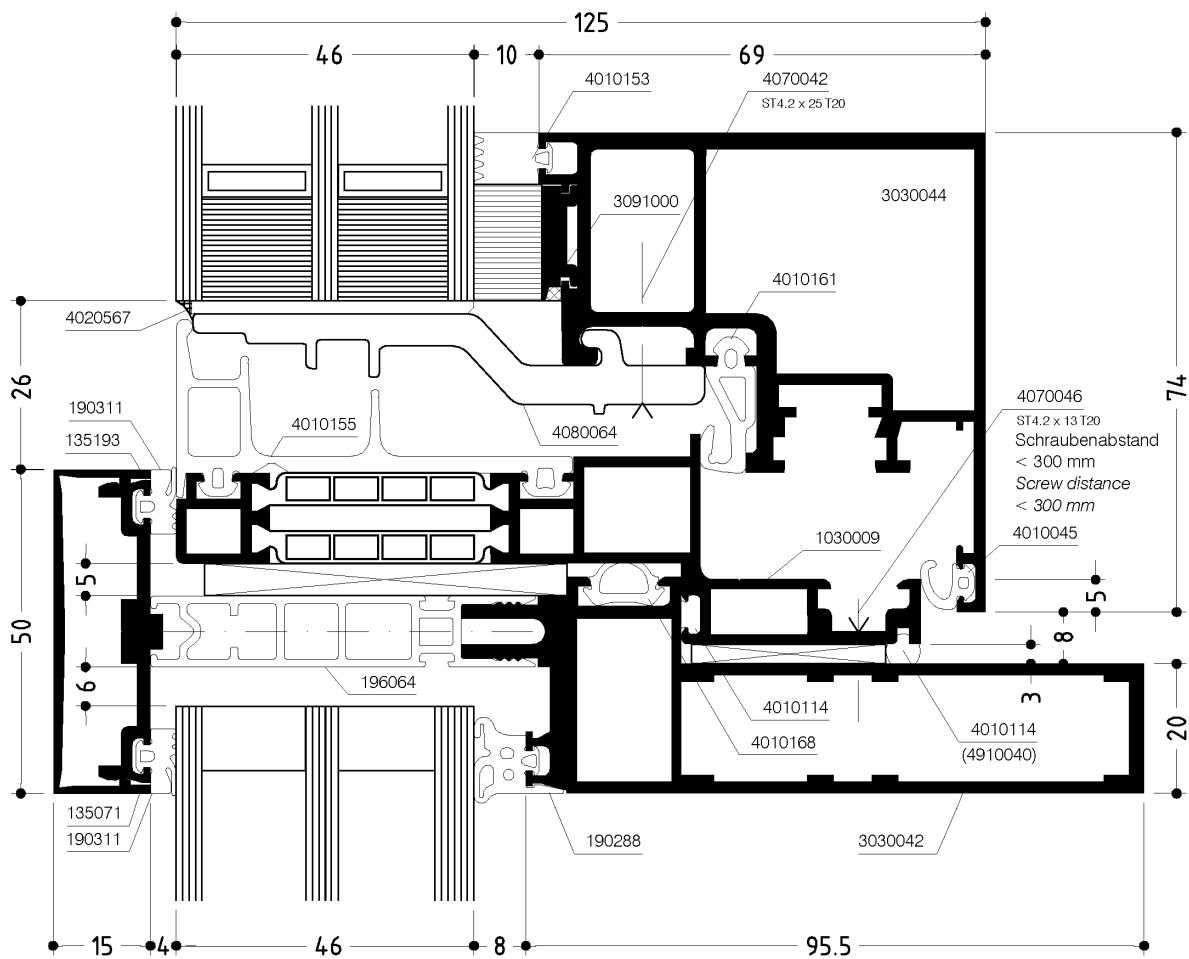
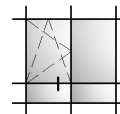

Fig. 6 Sash profile for glass thickness 40 – 62 mm with gasket 4010155 (upper transom section, 46 mm IGU)

# WICLINE 70SG

Flügelprofil für Glasdicke 40 - 62 mm mit Dichtung 4010155  
 Sash profile for glass thickness 40 - 62 mm with gasket 4010155

Konstruktionsschnitt  
 Construction section

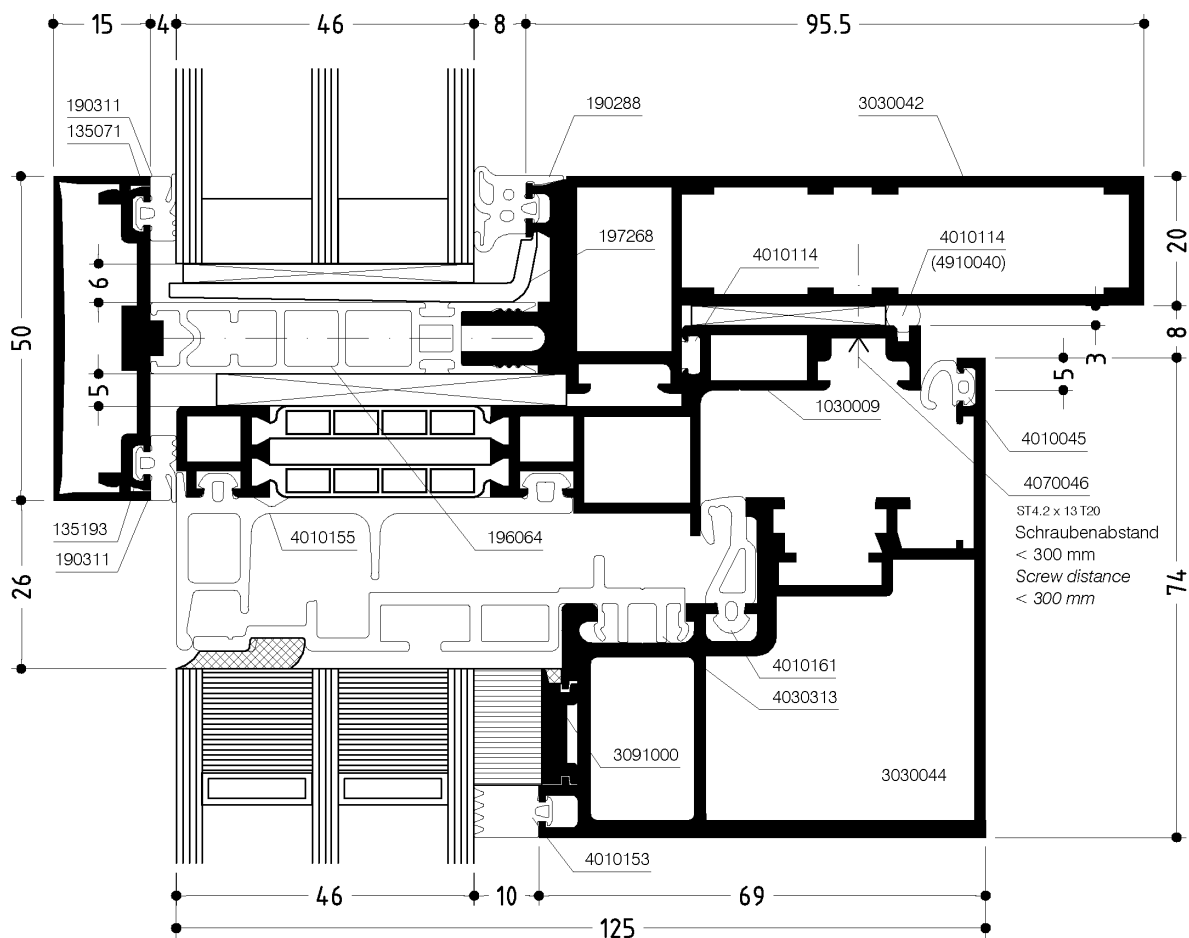
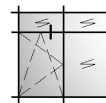

Fig. 7 Sash profile for glass thickness 40 – 62 mm with gasket 4010155 (mullion section, 46 mm IGU)

# WICLINE 70SG

Flügelprofil für Glasdicke 40 - 62 mm mit Dichtung 4010155  
 Sash profile for glass thickness 40 - 62 mm with gasket 4010155

Konstruktionsschnitt  
 Construction section

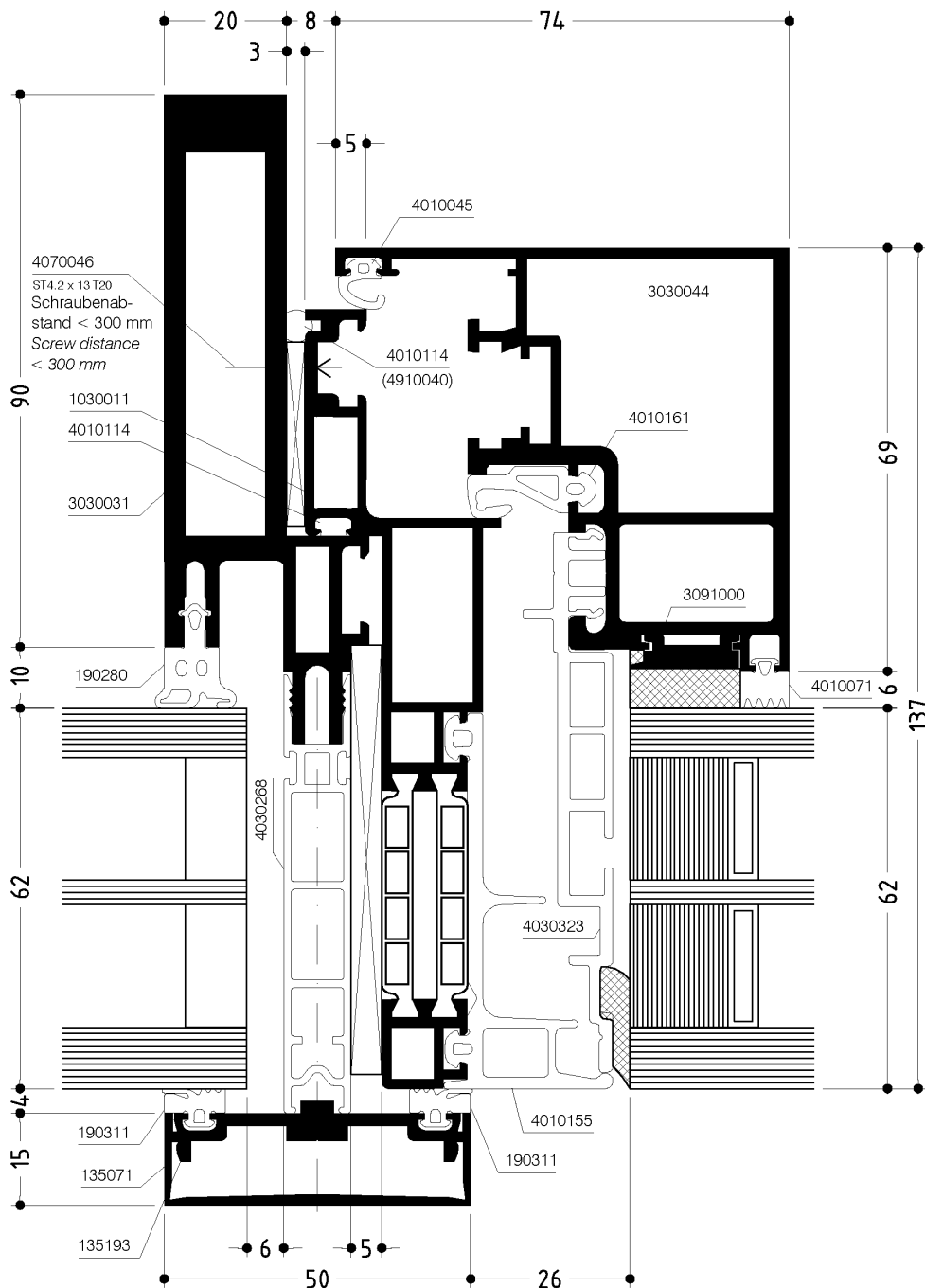
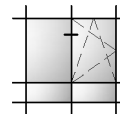

Fig. 8 Sash profile for glass thickness 40 – 62 mm with gasket 4010155 (lower transom section, 62 mm IGU)

# WICLINE 70SG

Flügelprofil für Glasdicke 40 - 62 mm mit Dichtung 4010155  
 Sash profile for glass thickness 40 - 62 mm with gasket 4010155

Konstruktionsschnitt  
 Construction section

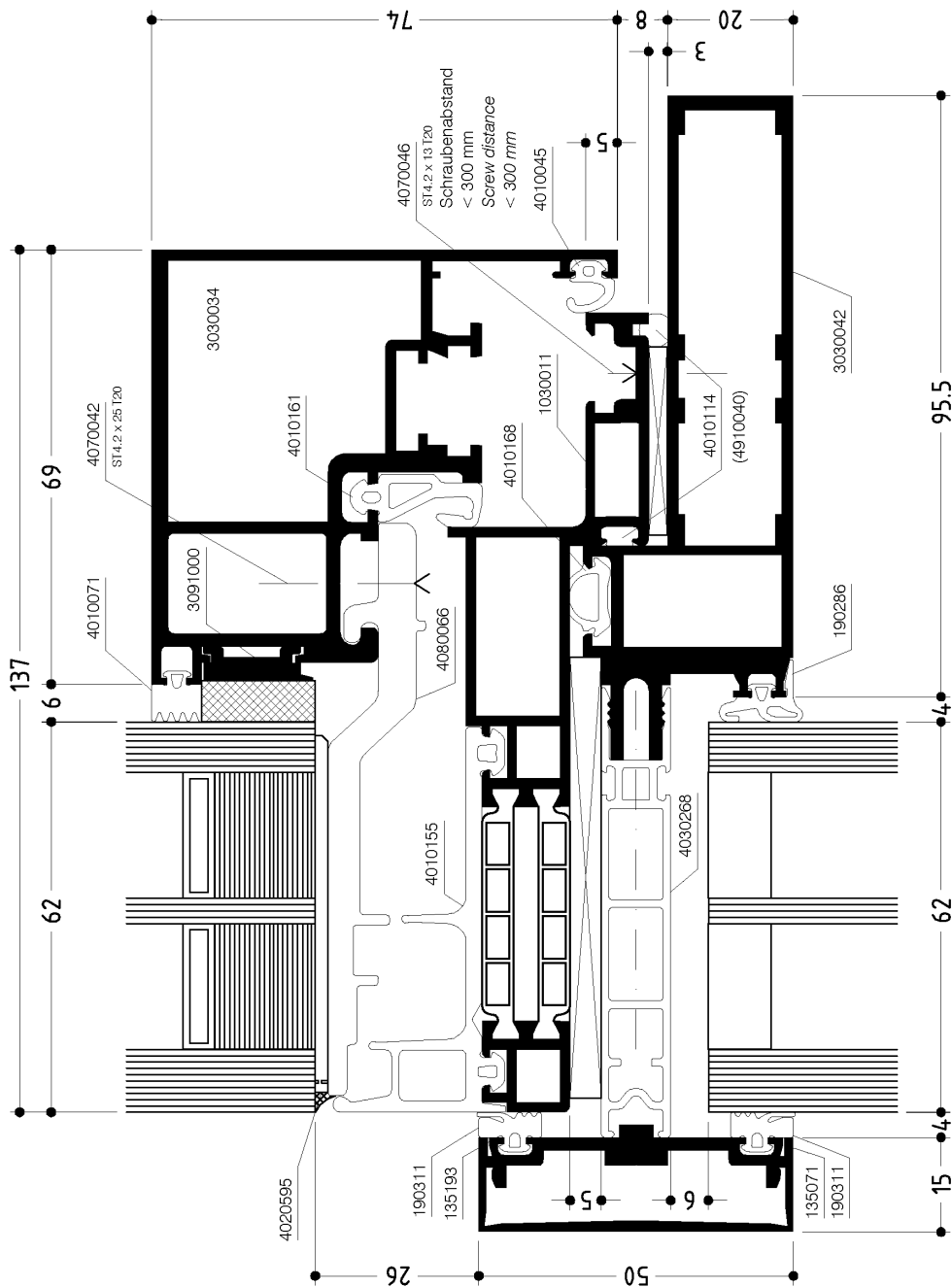
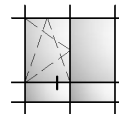

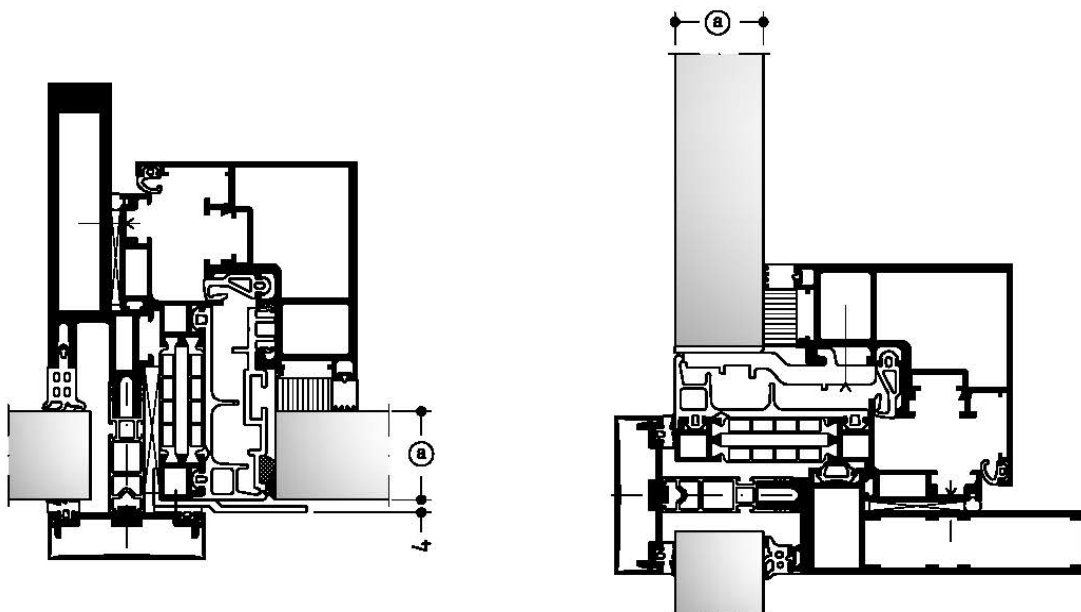

Fig. 10 Profiles and accessories for glass thickness 28 – 44 mm

# WICLINE 70SG

Füllungsdicken 28 - 44 mm  
 Infill thicknesses 28 - 44 mm

Auswahltabellen  
 Selection tables



28 30 32	3030033	4080060	4020567	4010153 (10) 4010072 (8) 4010071 (6)	1030007	4030168	4010154	4080058
34 36 38		4080081		4010153 (10) 4010072 (8) 4010071 (6)	1030008	4030169		
40 42 44		4080062		4010153 (10) 4010072 (8) 4010071 (6)	1030022	4030188		

Fig. 11 Profiles and accessories for glass thickness 40 – 62 mm

# WICLINE 70SG

Füllungsdicken 40 - 62 mm  
Infill thicknesses 40 - 62 mm

Auswahltabellen  
Selection tables

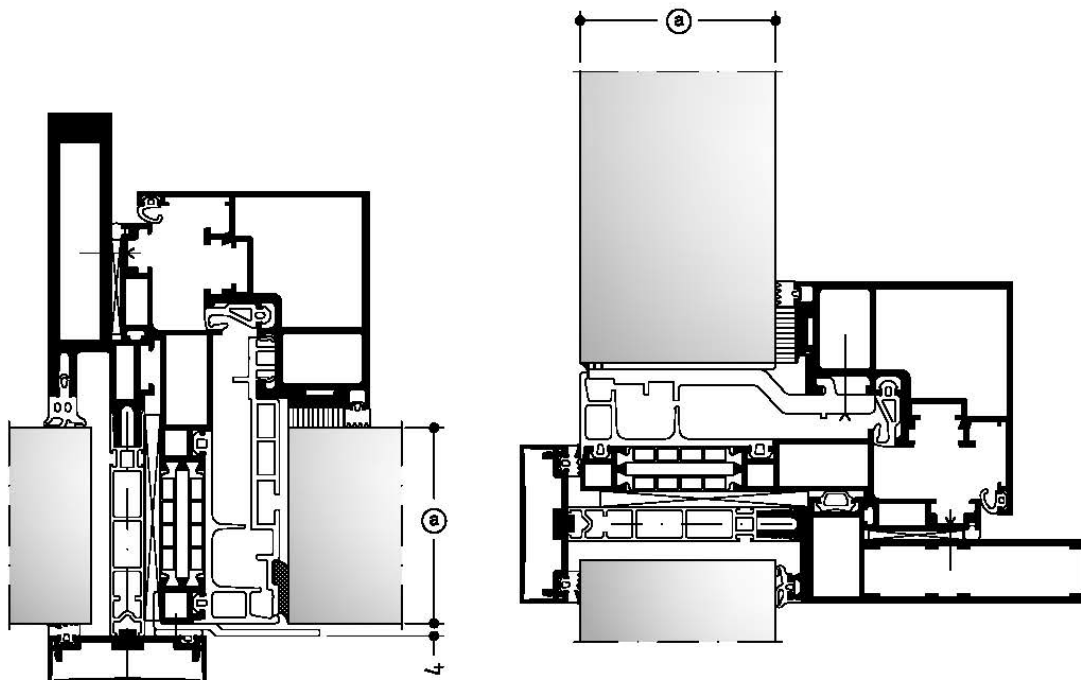

40 42 44	3030044	4080063	4020567	4010153 (10) 4010072 (8) 4010071 (6)	1030022	4030281	4010155	4080059
46 48 50		4080064	4020594	4010153 (10) 4010072 (8) 4010071 (6)	1030009	4030313		
52 54 56		4080065	4020595	4010153 (10) 4010072 (8) 4010071 (6)	1030010	4030317		
58 60 62		4080066		4010153 (10) 4010072 (8) 4010071 (6)	1030011	4030323		

Fig. 12 Alternative sashes

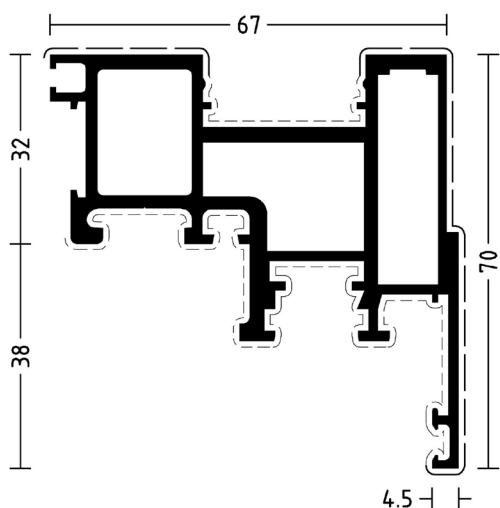

**3030058**

Eckverbindung innen:  
Zuschnitt aus 3900015 (9,60) + 2x 4070000  
Corner connection inside:  
Cutting with 3900015 (9,60) + 2x 4070000

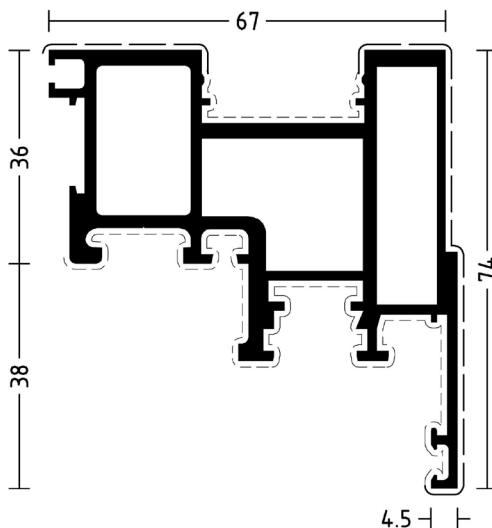

**3030059**

Eckverbindung innen:  
Zuschnitt aus 3000248 (9,60) + 2x 4070000  
Corner connection inside:  
Cutting with 3000248 (9,60) + 2x 4070000

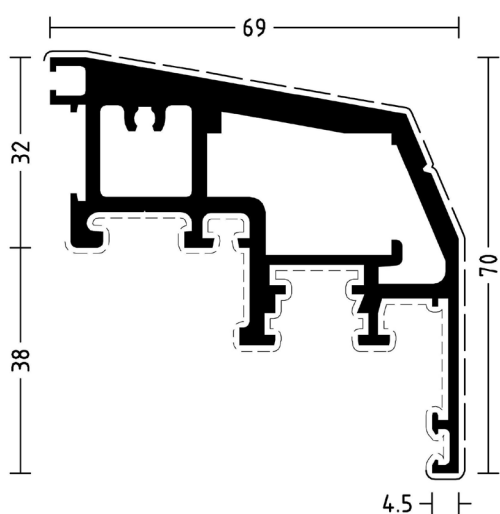

**3030065**

Eckverbindung außen:  
Schraube 1x 4070058  
Eckverbindung innen:  
Zuschnitt aus 3900066 (30,70 mit Aussparung) + 2x 4070000  
Aussparung siehe Verarbeitungsrichtlinien

Corner connection outside:  
Screw 1x 4070058  
Corner connection inside:  
Cutting with 3900066 (30,70 with groove) + 2x 4070000  
Groove see users manual

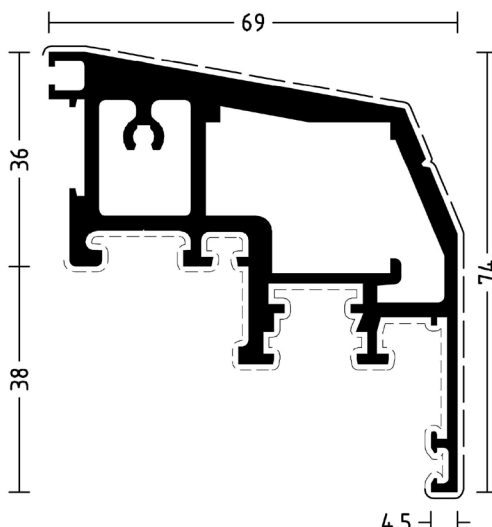

**3030067**

Eckverbindung außen:  
Schraube 1x 4070058  
Eckverbindung innen:  
Zuschnitt aus 3900014 (30,70 mit Aussparung) + 2x 4070000  
Aussparung siehe Verarbeitungsrichtlinien

Corner connection outside:  
Screw 1x 4070058  
Corner connection inside:  
Cutting with 3900014 (30,70 with groove) + 2x 4070000  
Groove see users manual

Fig. 13 Glazing supports

# WICLINE 70SG

Verglasungsvorklötze, zulässige Belastung F  
 Glazing supports, admissible load F

Technische Information  
 Technical Information

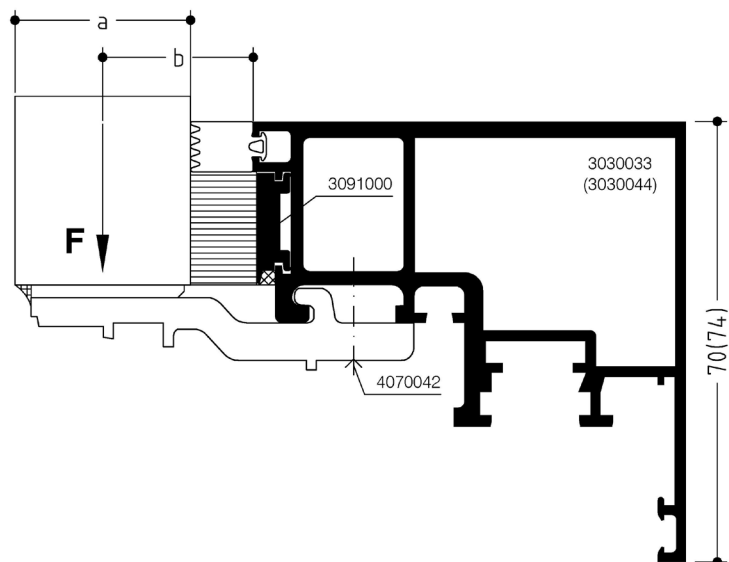



			
		F (N)	
28 - 32	4080060	1500	24
34 - 38	4080061	1500	27
40 - 44	4080062 4080063	1400	30
46 - 50	4080064	1400	33
52 - 56	4080065	1000	36
58 - 62	4080066	800	39

Fig. 14 Glazing supports - mounting

# WICLINE 70SG

Montage Glasauflage  
Mounting glazing overlay

Für Füllungsdicke ≤ 28 - 62 mm  
For Infill thickness ≤ 28 - 62 mm

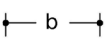
## Technische Information Technical Information

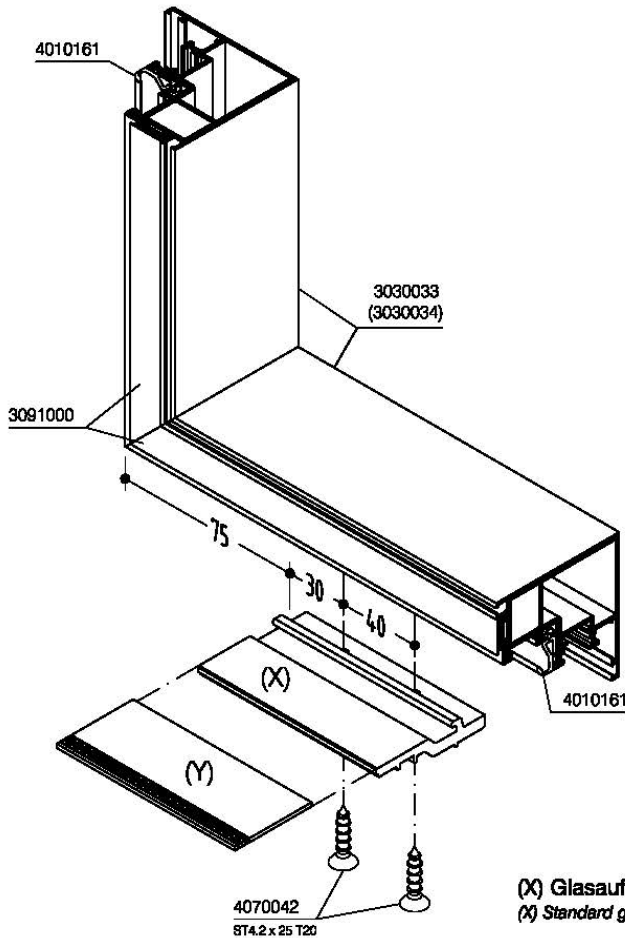
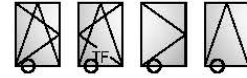

Bohren  
Ø3,5 mm  
Drilling



Vor montieren des Vorklotzes,  
Silikonvorklotz 4020567 aufkleben  
und auf entsprechendes Maß kürzen.  
Glue silicone shim 4020567 on  
aluminium glazing shim and shorten to  
the appropriate dimension prior to  
mounting.



3 Nm



Schrauben abdichten.  
Seal screws.

(X) Glasauflagen, Standard  
(X) Standard glazing overlays

Glaskategorie	Profil	(X)	(Y)
28 - 32	3030033	4080060	4020567
34 - 38		4080061	
40 - 44		4080062	
40 - 44	3030034	4080063	4020594
46 - 50		4080064	
52 - 56		4080065	4020595
58 - 62		4080066	

Fig. 15 Sash corner connection

# WICLINE 70SG

Eckverbindung, Flügelprofil  
 Corner connection of sash profile

Konstruktionspunkt  
 Construction point

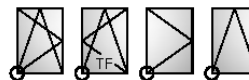

Verbindung mit Schlaghülse  
 Connection with drive bush



Profil 3091000 vor Eckverbindung einschieben  
 Push in profile 3091000 before corner connection

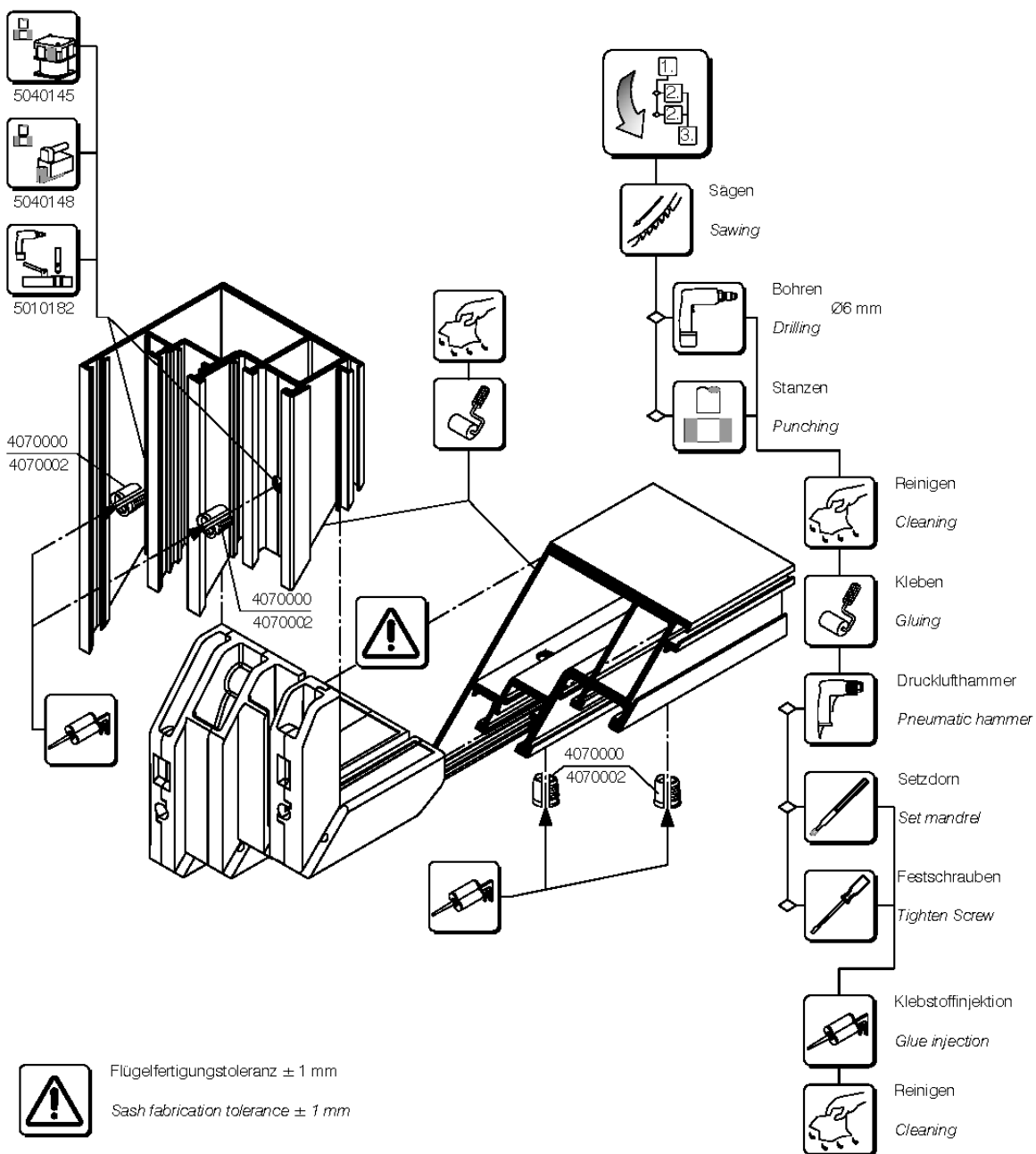
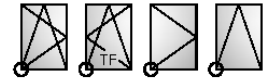

Fig. 16 Frame corner connection

# WICLINE 70SG

Eckverbindung, Rahmenprofil  
 Corner connection of frame profile

Konstruktionspunkt  
 Construction point



Verbindung mit Schlaghülse  
 Connection with drive bush

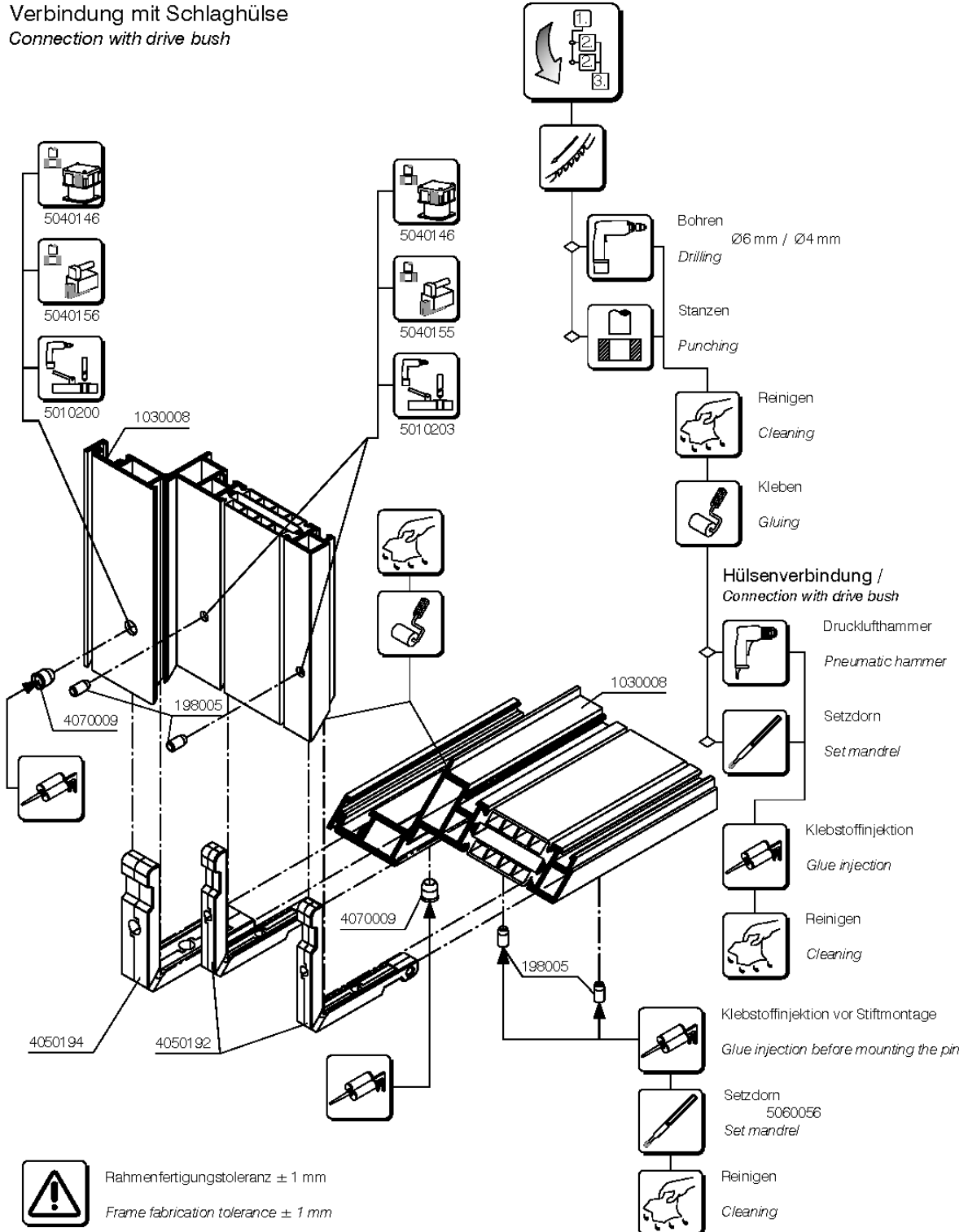

 Rahmenfertigungstoleranz  $\pm 1$  mm  
 Frame fabrication tolerance  $\pm 1$  mm

Fig. 17 Processing and sealing gaskets

# WICLINE 70SG

Bearbeitung und Versiegelung Dichtungen  
*Processing and sealing gaskets*

Konstruktionspunkt  
*Construction point*

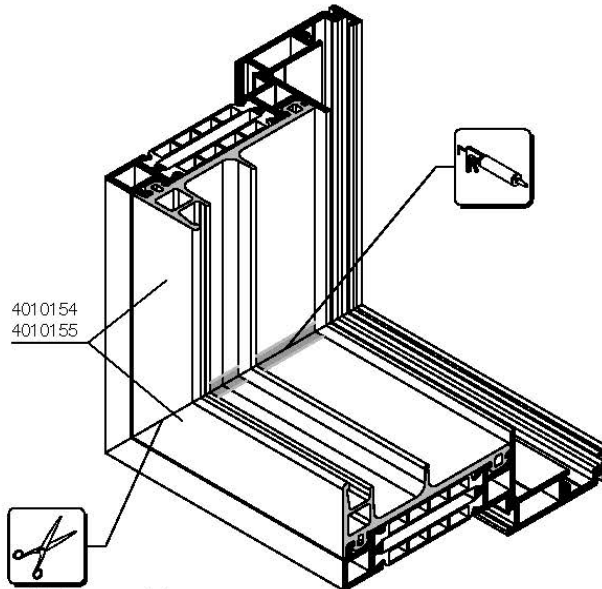
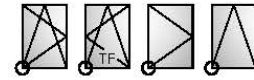

4010154  
 4010155

Auf Gehrung geschnitten  
 und gestoßen  
*Mitre cut and butt-joined*

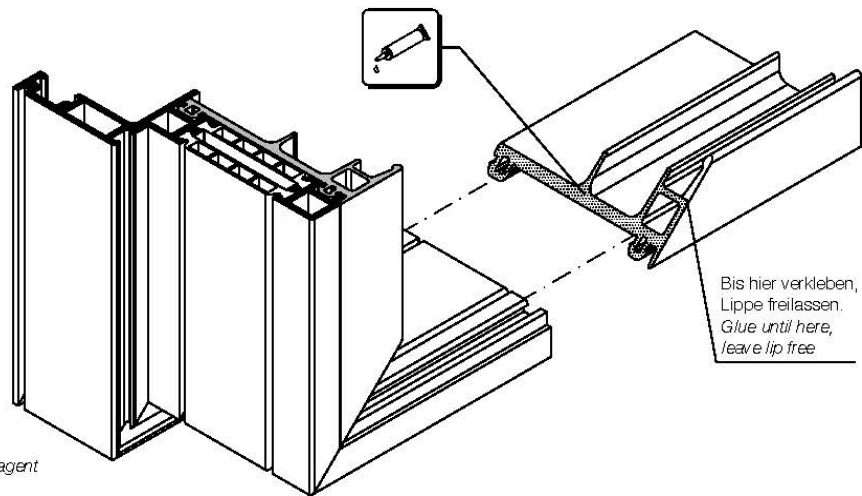

Bis hier verkleben,  
 Lippe freilassen.  
*Glue until here,  
 leave lip free*



Reinigungsmittel auf  
 Alkoholbasis  
 5970006  
*Alcohol based cleaning agent*



Schneidwerkzeug  
 5060029  
*Cutting tool*



Kleben  
 5070012  
*Gluing*



Silikon-Dichtmasse  
 5970003  
*Silicone sealant*

WICONA® 1501420

REV. B 24.05.2018

Fig. 18 IGU gluing – double pane IGU

# WICLINE 70SG

Glaselement  
Glass unit

Verklebung  
Gluing

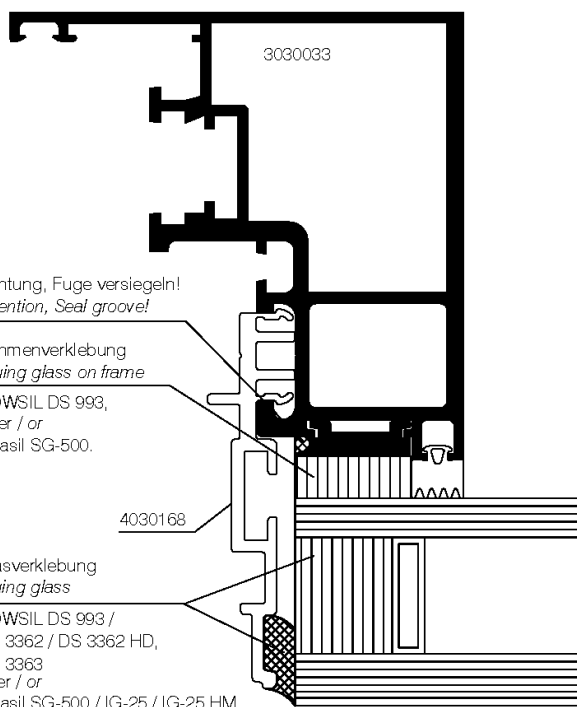
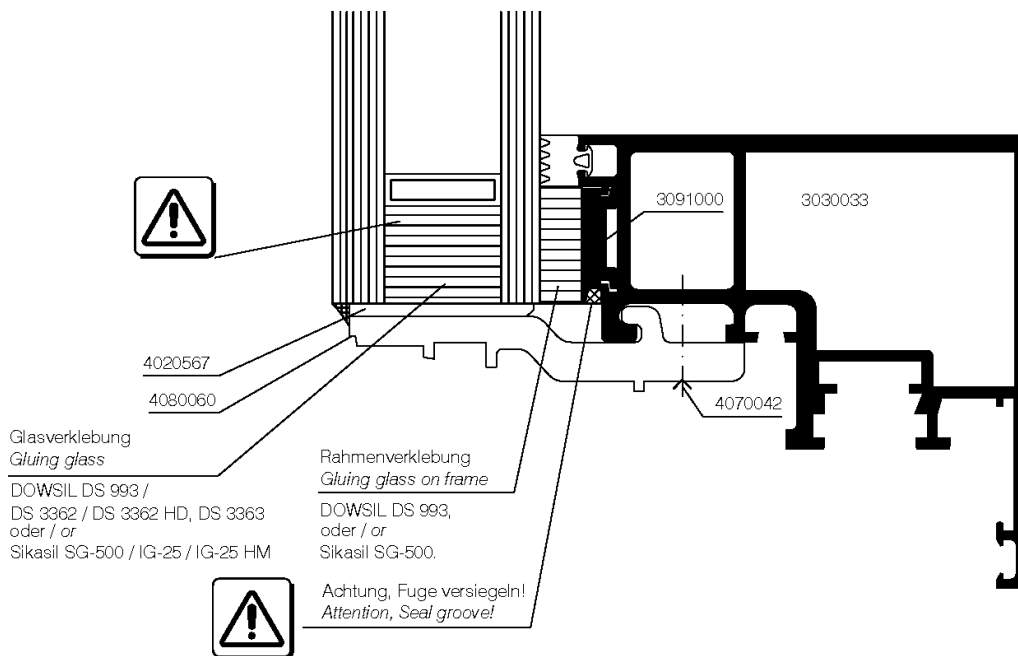

Verklebung nur in schwarz möglich!  
Can only be bonded in black!



Vorklotz nach bzw. während dem  
Verkleben sofort wieder einbauen!  
Mount glazing shim immediatly after respectively  
during gluing!



Die Fugendimensionierung erfolgt  
durch den Isolierglashersteller.  
The dimensioning of groove is done by the  
insulation glass manufacturer.

Fig. 19 IGU gluing – triple pane IGU

# WICLINE 70SG

Glaselement  
Glass unit

Verklebung  
Gluing

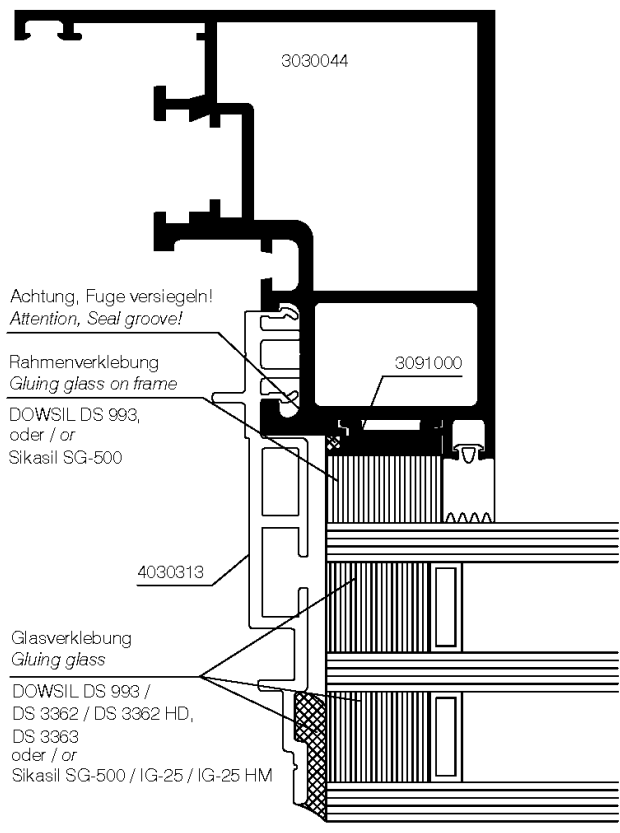
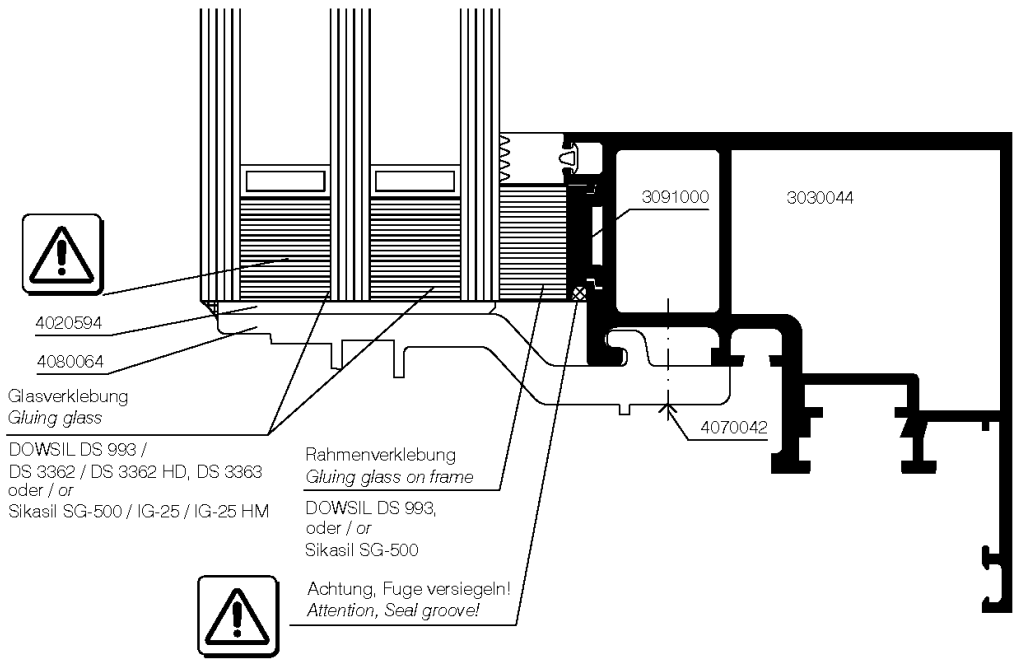

Verklebung nur in schwarz möglich!  
Can only be bonded in black!



Vorklotz nach bzw. während dem  
Verkleben sofort wieder einbauen!  
Mount glazing shim immediatly after respectively  
during gluing!



Die Fugendimensionierung erfolgt  
durch den Isolierglashersteller.  
The dimensioning of groove is done by the  
insulation glass manufacturer.

Fig. 20 Glass retaining device

# WICLINE 70SG

Glassicherung  
Glass safeguard

## Konstruktionspunkt Construction point

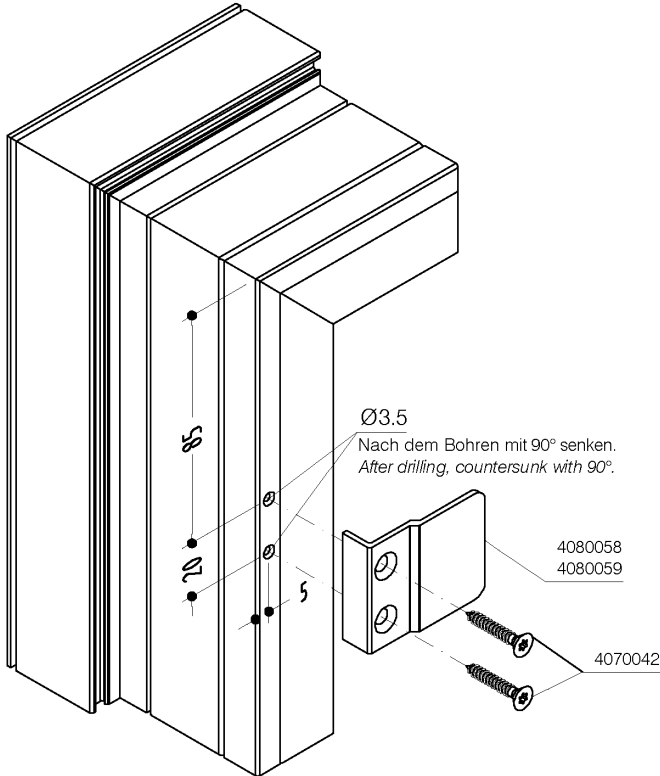
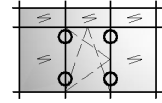

Bohren  
Ø3.5 mm  
Drilling



Bohrschablone  
5010204  
Drilling template



300 Nm



Schrauben abdichten.  
Seal screws.

\* Anzahl der Glassicherung  
entsprechend den Anforderungen  
Fzul. = 150 N

The number of glass safeguards  
according to requirements  
Fadm. = 150 N



Halter justieren, abbohren Ø 3.5 mm,  
senken und verschrauben.  
Schrauben abdichten.  
Adjust holder, drill out Ø 3.5 mm  
make countersunk and screw.  
Seal the screws.

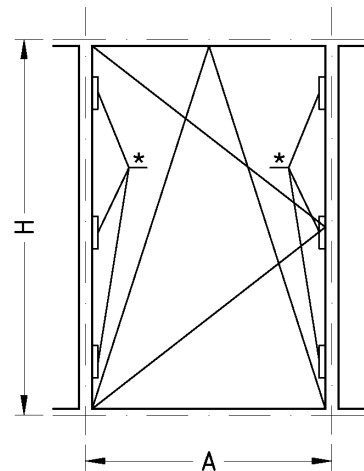
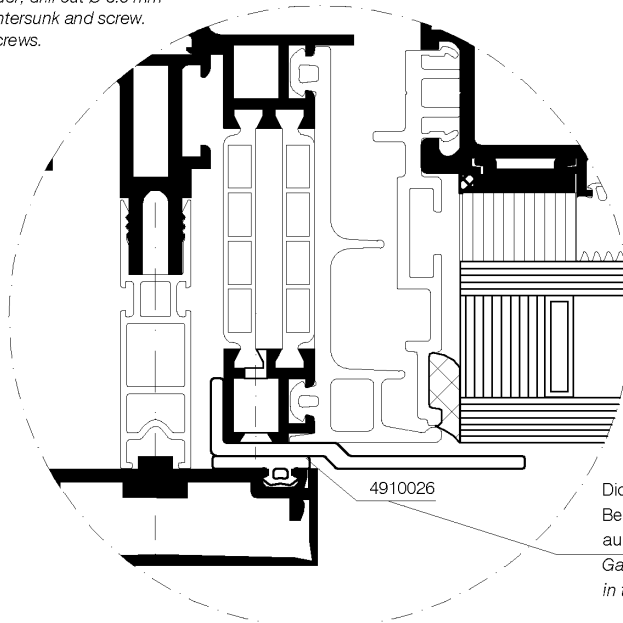

Dichtung 190311 muss im  
Bereich des Sicherungshalters  
ausgenommen werden  
Gasket 190311 must be notched  
in the glass safeguard area

Fig. 21 Air pressure equalization and drainage (isometric drawing)

# WICLINE 70SG

Dampfdruckausgleich und Entwässerung  
Air pressure equalization and drainage

Technische Information  
Technical Information

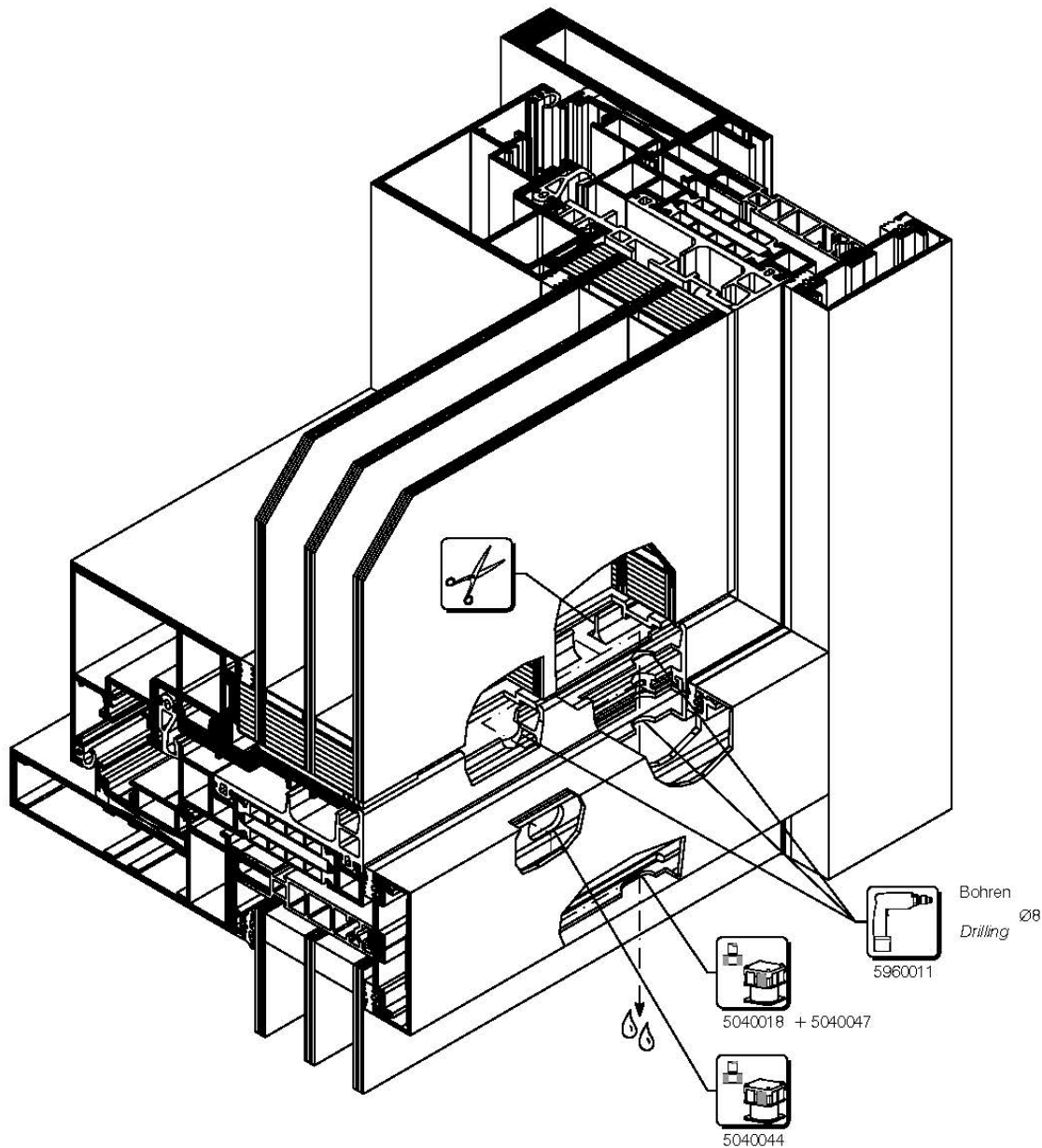
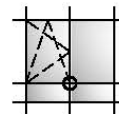
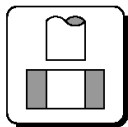
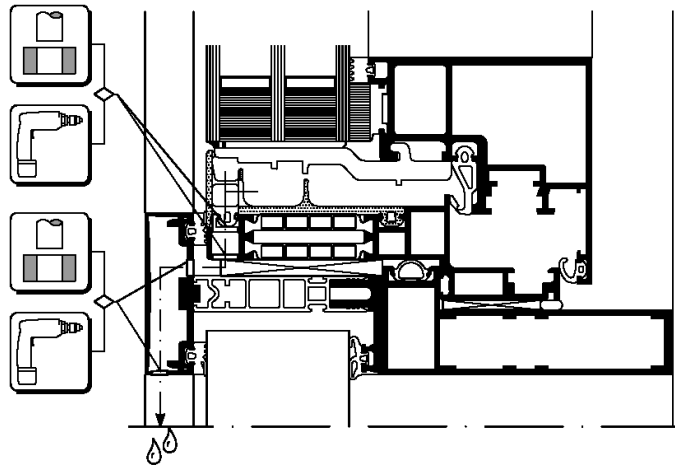

Fig. 22 Air pressure equalization and drainage (section drawing)

# WICLINE 70SG

Dampfdruckausgleich und Entwässerung  
Air pressure equalization and drainage

Technische Information  
Technical Information



Schlitze ins Profil stanzen  
- Alternativ: Fräsen

oder

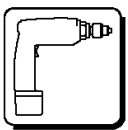

- Bohren

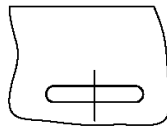

Punch slots in profile  
- Alternative: Milling

or

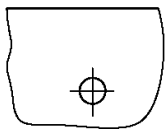

- Drilling



- Grundsätzliche Forderungen:**
- In die Vorkammer eingedringenes Wasser muss kontrolliert nach außen abgeleitet werden.
  - Es darf kein Wasser über:
    - + Konstruktionsstöße
    - + Konstruktionsdurchbrüche
    - + Pressta-Kerben
    - + Bohrungen für Verbinderbolzen
    - + Montageschrauben
 in die Konstruktion, das Bauwerk oder den Innenraum gelangen.
  - Entwässerung über Öffnungen nach außen.

- Basic requirements:**
- Infiltrated water in the prechamber must be drained in a controlled way towards the outside.
  - No water should infiltrate through:
    - + construction joints
    - + construction breakthroughs
    - + crimped notches
    - + boreholes for connector bolts
    - + mounting screws
 into the construction, the building or the interior rooms.
  - Drainage via openings towards outside.



Anforderung nur für Frankreich!  
Requirement only for France!

RLB	Anzahl der Öffnungen Number of openings
< 800 mm	2
< 800 mm	3 und mehr / and more
≥ 800 mm	3 und mehr / and more

RLH	Abstand "a" Distance "a"
< 1600 mm	----
≥ 1600 mm	≤ 600 mm
----	≤ 600 mm

RLH	Abstand "a" Distance "a"
< 1200 mm	----
≥ 1200 mm	≤ 500 mm
----	≤ 500 mm